

PHYSICS

Exemplar Problems

Class XII

**EXEMPLAR PROBLEMS
IN
PHYSICS**

CLASS XII



राष्ट्रीय शैक्षिक अनुसंधान और प्रशिक्षण परिषद्
NATIONAL COUNCIL OF EDUCATIONAL RESEARCH AND TRAINING

© NCERT
not to be republished

ISBN 978-93-5007-168-7

First Edition
August 2011 Shravana 1933

PD 10T RNB

**© National Council of Educational
Research and Training, 2011**

00.00

*Printed on 80 GSM paper with NCERT
watermark*

Published at the Publication Department
by the Secretary, National Council of
Educational Research and Training,
Sri Aurobindo Marg, New Delhi 110 016
and printed at Gita Offset Printers Pvt.
Ltd., C-90, Okhla Industrial Area,
Phase -1, New Delhi 110 020

ALL RIGHTS RESERVED

- ❑ No part of this publication may be reproduced, stored in a retrieval system or transmitted, in any form or by any means, electronic, mechanical, photocopying, recording or otherwise without the prior permission of the publisher.
- ❑ This book is sold subject to the condition that it shall not, by way of trade, be lent, re-sold, hired out or otherwise disposed of without the publisher's consent, in any form of binding or cover other than that in which it is published.
- ❑ The correct price of this publication is the price printed on this page, Any revised price indicated by a rubber stamp or by a sticker or by any other means is incorrect and should be unacceptable.

**OFFICES OF THE PUBLICATION
DEPARTMENT, NCERT**

NCERT Campus
Sri Aurobindo Marg
New Delhi 110 016 Phone : 011-26562708

108, 100 Feet Road
Hosdakere Halli Extension
Banashankari III Stage
Bangalore 560 085 Phone : 080-26725740

Navjivan Trust Building
P.O.Navjivan
Ahmedabad 380 014 Phone : 079-27541446

CWC Campus
Opp. Dhankal Bus Stop
Panihati
Kolkata 700 114 Phone : 033-25530454

CWC Complex
Maligaon
Guwahati 781 021 Phone : 0361-2674869

Publication Team

Head, Publication : *Neerja Shukla*
Department

Chief Production : *Shiv Kumar*
Officer

Chief Editor : *Shveta Uppal*

Chief Business : *Gautam Ganguly*
Manager

Assistant Editor : *R.N. Bhardwaj*

Assistant Production : *Atul Saxena*
Officer

Cover Design

Shweta Rao

FOREWORD

The National Curriculum Framework (NCF)–2005 initiated a new phase of development of syllabi and textbooks for all stages of school education. Conscious efforts have been made to discourage rote learning and to diffuse sharp boundaries between different subject areas. This is well in tune with the National Policy on Education (NPE)–1986 and *Learning Without Burden*–1993 that recommend child centred system of education. The textbooks for Classes IX and XI were released in 2006 and for Classes X and XII in 2007. Overall the books have been well received by students and teachers.

NCF–2005 notes that treating the prescribed textbooks as the sole basis of examination is one of the key reasons why other resources and sites of learning are ignored. It further reiterates that the methods used for teaching and evaluation will also determine how effective these textbooks prove for making children's life at school a happy experience, rather than source of stress or boredom. It calls for reform in examination system currently prevailing in the country.

The position papers of the National Focus Groups on *Teaching of Science*, *Teaching of Mathematics* and *Examination Reform* envisage that the physics question papers, set in annual examinations conducted by the various Boards do not really assess genuine understanding of the subjects. The quality of questions papers is often not up to the mark. They usually seek mere information based on rote memorisation, and fail to test higher-order skills like reasoning and analysis, let alone lateral thinking, creativity, and judgment. Good unconventional questions, challenging problems and experiment-based problems rarely find a place in question papers. In order to address the issue, and also to provide additional learning material, the Department of Education in Science and Mathematics (DESM) has made an attempt to develop resource book of exemplar problems in different subjects at secondary and higher secondary stages. Each resource book contains different types of questions of varying difficulty level. Some questions would require the students to apply simultaneously understanding of more than one chapters/units. These problems are not meant to serve merely as question bank for examinations but are primarily meant to improve the quality of teaching/learning process in schools. It is expected that these problems would encourage teachers to design quality questions on their own. Students and teachers should always keep in mind that examination and assessment should test comprehension, information recall, analytical thinking and problem- solving ability, creativity and speculative ability.

A team of experts and teachers with an understanding of the subject and a proper role of examinations worked hard to accomplish this task. The material was discussed, edited, and finally included in this resource book.

National Council of Educational Research and Training (NCERT) would welcome suggestions from students, teachers and parents which would help us to further improve the quality of material in subsequent editions.

New Delhi
21 May 2008

Yash Pal
Chairperson
National Steering Committee
National Council of Educational
Research and Training

PREFACE

The Department of Education in Science and Mathematics (DESM), National Council of Educational Research and Training (NCERT), initiated the development of 'Exemplar Problems' in science and mathematics for secondary and higher secondary stages after completing the preparation of textbooks based on National Curriculum Framework (NCF)–2005.

The main objective of the book on 'Exemplar Problems in Physics' is to provide the teachers and students a large number of quality problems with varying cognitive levels to facilitate teaching/learning of concepts in physics that are presented through the textbook for Class XII. It is envisaged that the problems included in this volume would help the teachers to design tasks to assess effectiveness of their teaching and to know about the achievement of their students besides facilitating preparation of balanced question papers for unit and terminal tests. The feedback based on the analysis of students' responses may help the teachers in further improving the quality of classroom instructions. In addition, the problems given in this book are also expected to help the teachers to perceive the basic characteristics of good quality questions and motivate them to frame similar questions on their own. Students can benefit themselves by attempting the exercises given in the book for self assessment and also in mastering the basic techniques of problem solving. Some of the questions given in the book are expected to challenge the understanding of the concepts of physics of the students and their ability to applying them in novel situations.

The problems included in this book were prepared through a series of workshops organised by the DESM for their development and refinement involving practicing teachers, subject experts from universities and institutes of higher learning, and the members of the physics group of the DESM whose names appear separately. We gratefully acknowledge their efforts and thank them for their valuable contribution in our endeavour to provide good quality instructional material for the school system.

I express my gratitude to Professor Krishna Kumar, *Director and* Professor G.Ravindra, *Joint Director*, NCERT for their valuable motivation and guidance from time to time. Special thanks are also due to Dr V.P.Srivastava, *Reader*, DESM for coordinating the programme, taking pains in editing and refinement of problems and for making the manuscript pressworthy.

We look forward to feedback from students, teachers and parents for further improvement of the contents of this book.

Hukum Singh
Professor and Head, DESM
National Council of Educational
Research and Training

DEVELOPMENT TEAM

MEMBERS

A.W.Joshi, *Professor (Rtd)*, Department of Physics, University of Pune, Pune

Aprajita, *PGT (Physics)*, Kendriya Vidyalaya No.3, Delhi Cantt, New Delhi

Atul Mody, *Lecturer (SG)*, Department of Physics, VES College of Arts, Science and Commerce, Chembur, Mumbai

B.K.Sharma, *Professor (Rtd)*, Department of Education in Science and Mathematics, NCERT, New Delhi

Gagan Gupta, *Reader*, Department of Education in Science and Mathematics, NCERT, New Delhi

H.S.Mani, *Raja Ramanna Fellow*, Institute of Mathematical Sciences, Chennai.

Kiran Nayak, *PGT (Physics)*, Apeejay School, Pitampura, New Delhi

M.A.H.Ahsan, *Lecturer*, Department of Physics, Jamia Millia Islamia, New Delhi

P. Arun, *Reader*, SGTB Khalsa College, University of Delhi, Delhi

Pragya Nopany, *PGT (Physics)*, Birla Vidya Niketan, Pushpa Vihar, New Delhi

Pushpa Tyagi, *PGT (Physics)*, Sanskriti School, Chanakya Puri, New Delhi

Ravi Bhattacharjee, *Reader*, SGTB Khalsa College, University of Delhi, Delhi

R. Joshi, *Lecturer (SG)*, Department of Education in Science and Mathematics, NCERT, New Delhi

S.Rai Choudhury, *Raja Ramanna Fellow*, Centre for Theoretical Physics, Jamia Millia Islamia, New Delhi

S.D.Joglekar, *Professor*, Department of Physics, I.I.T., Kanpur

Shashi Prabha, *Lecturer*, Department of Education in Science and Mathematics, NCERT, New Delhi

Suchitra Basu Kasturi, *PGT (Physics)*, Sardar Patel Vidyalaya, Lodi Estate, New Delhi

MEMBER-COORDINATOR

V.P.Srivastava, *Reader*, Department of Education in Science and Mathematics, NCERT, New Delhi

ACKNOWLEDGEMENT

The National Council of Educational Research and Training (NCERT) acknowledges the valuable contribution of the individuals and organisations involved in the development of Exemplar Problems in Physics for Class XII. The Council also acknowledges the valuable contributions of the following academics for reviewing and refining the manuscripts of this book: A. A Rangwala, *Professor (Rtd)*, Department of Physics, University of Mumbai, Mumbai; Girija Shankar, *PGT (Physics)*, Rajkiya Pratibha Vikas Vidyalaya, Surajmal Vihar, Delhi; Indra Saini, *PGT (Physics)*, Ramjas School, Pusa Road, New Delhi; Lata Kumari, *PGT (Physics)*, Chinmaya Vidyalaya, Vasant Vihar, New Delhi; R. S Dass, *Vice-Principal (Rtd)*, BVB Senior Secondary, School, Lajpat Nagar, New Delhi; Shirish Pathare, *Scientific Officer, 'D'*, Homi Bhabha Centre for Science Education, V.N. Purav Marg, Mumbai; Vandana Grover, *PGT (Physics)*, DAV Public School, Sector 14, Gurgaon; Vinod Prakash, *Professor (Rtd)*, Department of Physics, University of Allahabad, Allahabad; and Yashu Kumar, *PGT (Physics)*, Kulachi Hans Raj Model School, Ashok Vihar, New Delhi. Special thanks are due to Professor Dipan Ghosh, Department of Physics, IIT, Mumbai for his continued support to this task; and providing some problems for Chapter VII.

Thanks are due to Hukum Singh, *Professor and Head*, DESM, NCERT for his support.

The Council also acknowledges the efforts of Deepak Kapoor, *Incharge*, Computer Station; Kamlesh Rao, Ritu Jha and Jitender, *DTP Operator*.

The contribution of the Publication Department in bringing out this book is duly acknowledged.

CHILDREN'S BILL OF RIGHTS

A child is every person under the age of 18 years. Parents have the primary responsibility for the upbringing and development of the child. The State shall respect and ensure the rights of the child.



- I have the Right to express my views freely which should be taken seriously, and everyone has the Responsibility to listen to others. (Article 12,13)



- I have the Right to good health care, and everyone has the Responsibility to help others get basic health care and clean water. (Article 24)
- I have the Right to a good education, and everyone has the Responsibility to encourage all children to go to school. (Article 28,29,23)



- I have the Right to be loved and protected from harm and abuse, and everyone has the Responsibility to love and care for others. (Article 19)
- I have the Right to be included whatever my abilities, and everyone has the Responsibility to respect others for their differences. (Article 23)
- I have the Right to be proud of my heritage and beliefs, and everyone has the Responsibility to respect the culture and belief of others. (Article 29,30)



- I have the Right to a safe and comfortable home and everyone has the Responsibility to make sure all children have homes. (Article 27)
- I have the Right to make mistakes, and everyone has the Responsibility to accept we can learn from our mistakes. (Article 28)



- I have the Right to be well fed, and everyone has the Responsibility to prevent people from starving. (Article 24)
- I have the Right to a clean environment, and everyone has the Responsibility not to pollute it. (Article 29)



- I have the Right to live without violence (verbal, physical, emotional), and everyone has the Responsibility not to be violent to others. (Article 28,37)
- I have the Right to be protected from economic and sexual exploitation, and everyone has the Responsibility to ensure that no child is forced to work and is given a free and secure environment. (Article 32,34)

These rights and responsibilities are enshrined in the United Nations Convention on the Rights of the Child, 1989. It contains all the rights which children and young people have all over the world. The Government of India signed this document in 1992.

CONTENTS

FOREWORD	<i>iii</i>
PREFACE	v
CHAPTER ONE ELECTRIC CHARGES AND FIELDS	1
CHAPTER TWO ELECTROSTATIC POTENTIAL AND CAPACITANCE	10
CHAPTER THREE CURRENT ELECTRICITY	16
CHAPTER FOUR MOVING CHARGES AND MAGNETISM	22
CHAPTER FIVE MAGNETISM AND MATTER	28
CHAPTER SIX ELECTROMAGNETIC INDUCTION	33
CHAPTER SEVEN ALTERNATING CURRENT	40
CHAPTER EIGHT ELECTROMAGNETIC WAVES	47
CHAPTER NINE RAY OPTICS AND OPTICAL INSTRUMENTS	54
CHAPTER TEN WAVE OPTICS	62
CHAPTER ELEVEN DUAL NATURE OF RADIATION AND MATTER	68
CHAPTER TWELVE ATOMS	75
CHAPTER THIRTEEN NUCLEI	81

CHAPTER FOURTEEN SEMICONDUCTOR ELECTRONICS: MATERIALS, DEVICES AND SIMPLE CIRCUITS	87
CHAPTER FIFTEEN COMMUNICATION SYSTEMS	98
ANSWERS	106
SAMPLE QUESTION PAPERS	198

© NCERT
not to be republished

Chapter One

ELECTRIC CHARGES AND FIELDS



MCQ I

- 1.1** In Fig.1.1, two positive charges q_2 and q_3 fixed along the y axis, exert a net electric force in the $+x$ direction on a charge q_1 fixed along the x axis. If a positive charge Q is added at $(x, 0)$, the force on q_1

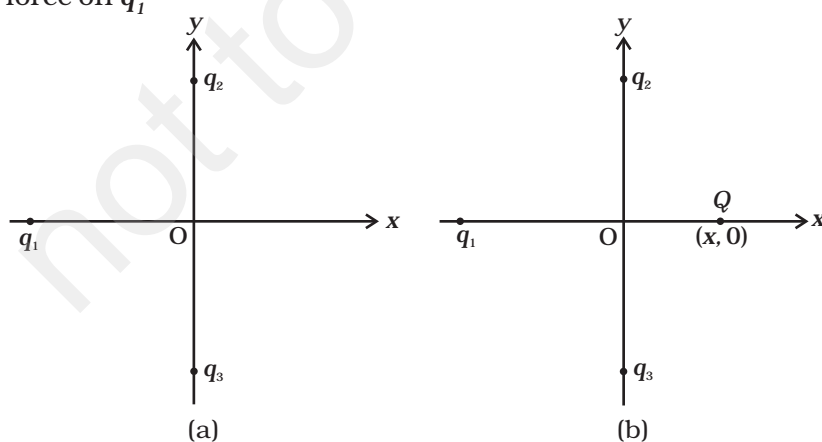

Fig. 1.1

- (a) shall increase along the positive x -axis.
- (b) shall decrease along the positive x -axis.
- (c) shall point along the negative x -axis.
- (d) shall increase but the direction changes because of the intersection of Q with q_2 and q_3 .

1.2 A point positive charge is brought near an isolated conducting sphere (Fig. 1.2). The electric field is best given by

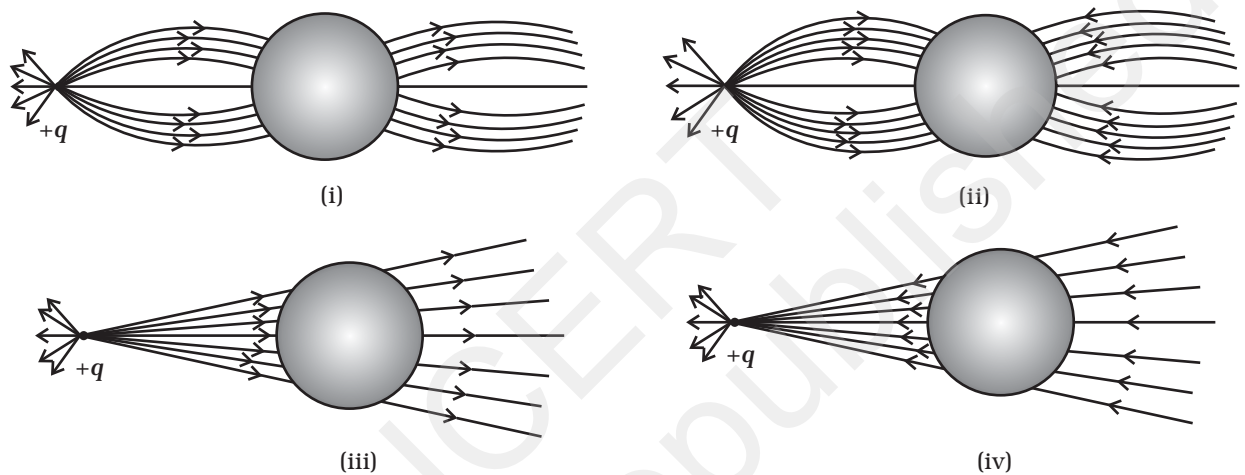

Fig. 1.2

- (a) Fig (i)
- (b) Fig (ii)
- (c) Fig (iii)
- (d) Fig (iv)

1.3 The Electric flux through the surface

- (a) in Fig. 1.3 (iv) is the largest.
- (b) in Fig. 1.3 (iii) is the least.
- (c) in Fig. 1.3 (ii) is same as Fig. 1.3 (iii) but is smaller than Fig. 1.3 (iv)
- (d) is the same for all the figures.

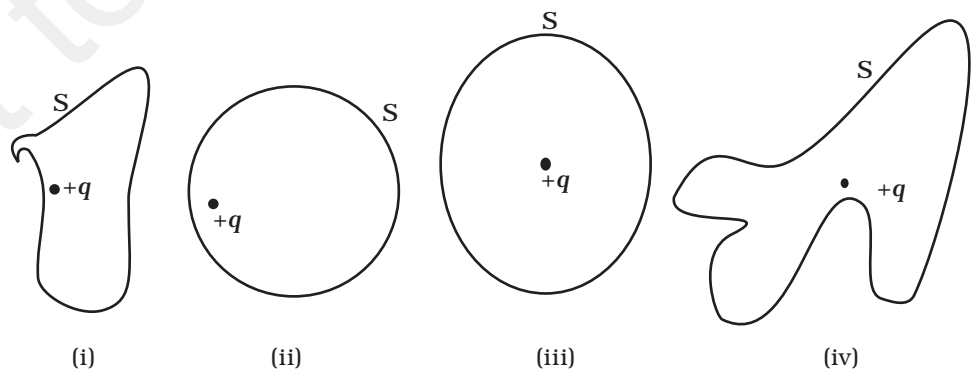

Fig. 1.3

- 1.4** Five charges $q_1, q_2, q_3, q_4,$ and q_5 are fixed at their positions as shown in Fig. 1.4. S is a Gaussian surface. The Gauss's law is given by

$$\oint_S \mathbf{E} \cdot d\mathbf{s} = \frac{q}{\epsilon_0}$$

Which of the following statements is correct?

- \mathbf{E} on the LHS of the above equation will have a contribution from q_1, q_5 and q_3 while q on the RHS will have a contribution from q_2 and q_4 only.
- \mathbf{E} on the LHS of the above equation will have a contribution from all charges while q on the RHS will have a contribution from q_2 and q_4 only.
- \mathbf{E} on the LHS of the above equation will have a contribution from all charges while q on the RHS will have a contribution from q_1, q_3 and q_5 only.
- Both \mathbf{E} on the LHS and q on the RHS will have contributions from q_2 and q_4 only.

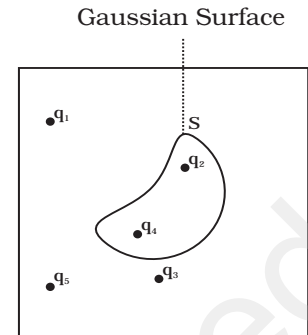

Fig. 1.4

- 1.5** Figure 1.5 shows electric field lines in which an electric dipole \mathbf{p} is placed as shown. Which of the following statements is correct?

- The dipole will not experience any force.
- The dipole will experience a force towards right.
- The dipole will experience a force towards left.
- The dipole will experience a force upwards.

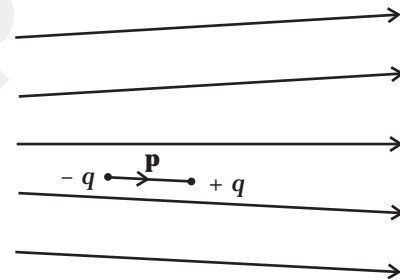

Fig. 1.5

- 1.6** A point charge $+q,$ is placed at a distance d from an isolated conducting plane. The field at a point P on the other side of the plane is

- directed perpendicular to the plane and away from the plane.
- directed perpendicular to the plane but towards the plane.
- directed radially away from the point charge.
- directed radially towards the point charge.

- 1.7** A hemisphere is uniformly charged positively. The electric field at a point on a diameter away from the centre is directed

- perpendicular to the diameter
- parallel to the diameter
- at an angle tilted towards the diameter
- at an angle tilted away from the diameter.

MCQ II

1.8 If $\oiint_S \mathbf{E} \cdot d\mathbf{S} = 0$ over a surface, then

- (a) the electric field inside the surface and on it is zero.
- (b) the electric field inside the surface is necessarily uniform.
- (c) the number of flux lines entering the surface must be equal to the number of flux lines leaving it.
- (d) all charges must necessarily be outside the surface.

1.9 The Electric field at a point is

- (a) always continuous.
- (b) continuous if there is no charge at that point.
- (c) discontinuous only if there is a negative charge at that point.
- (d) discontinuous if there is a charge at that point..

1.10 If there were only one type of charge in the universe, then

- (a) $\oiint_S \mathbf{E} \cdot d\mathbf{S} \neq 0$ on any surface.
- (b) $\oiint_S \mathbf{E} \cdot d\mathbf{S} = 0$ if the charge is outside the surface.
- (c) $\oiint_S \mathbf{E} \cdot d\mathbf{S}$ could not be defined.
- (d) $\oiint_S \mathbf{E} \cdot d\mathbf{S} = \frac{q}{\epsilon_0}$ if charges of magnitude q were inside the surface.

1.11 Consider a region inside which there are various types of charges but the total charge is zero. At points outside the region

- (a) the electric field is necessarily zero.
- (b) the electric field is due to the dipole moment of the charge distribution only.
- (c) the dominant electric field is $\propto \frac{1}{r^3}$, for large r , where r is the distance from a origin in this region.
- (d) the work done to move a charged particle along a closed path, away from the region, will be zero.

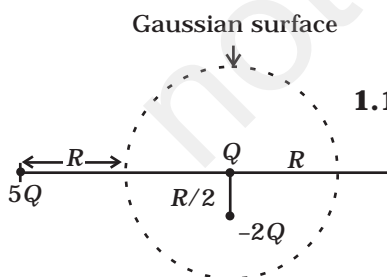

Fig. 1.6

1.12 Refer to the arrangement of charges in Fig. 1.6 and a Gaussian surface of radius R with Q at the centre. Then

- (a) total flux through the surface of the sphere is $\frac{-Q}{\epsilon_0}$.
- (b) field on the surface of the sphere is $\frac{-Q}{4\pi\epsilon_0 R^2}$.

- (c) flux through the surface of sphere due to $5Q$ is zero.
- (d) field on the surface of sphere due to $-2Q$ is same everywhere.

1.13 A positive charge Q is uniformly distributed along a circular ring of radius R . A small test charge q is placed at the centre of the ring (Fig. 1.7). Then

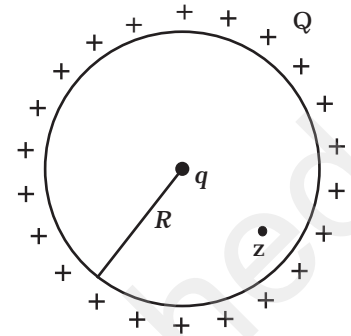

Fig. 1.7

- (a) If $q > 0$ and is displaced away from the centre in the plane of the ring, it will be pushed back towards the centre.
- (b) If $q < 0$ and is displaced away from the centre in the plane of the ring, it will never return to the centre and will continue moving till it hits the ring.
- (c) If $q < 0$, it will perform SHM for small displacement along the axis.
- (d) q at the centre of the ring is in an unstable equilibrium within the plane of the ring for $q > 0$.

VSA

- 1.14** An arbitrary surface encloses a dipole. What is the electric flux through this surface?
- 1.15** A metallic spherical shell has an inner radius R_1 and outer radius R_2 . A charge Q is placed at the centre of the spherical cavity. What will be surface charge density on (i) the inner surface, and (ii) the outer surface?
- 1.16** The dimensions of an atom are of the order of an Angstrom. Thus there must be large electric fields between the protons and electrons. Why, then is the electrostatic field inside a conductor zero?
- 1.17** If the total charge enclosed by a surface is zero, does it imply that the electric field everywhere on the surface is zero? Conversely, if the electric field everywhere on a surface is zero, does it imply that net charge inside is zero.
- 1.18** Sketch the electric field lines for a uniformly charged hollow cylinder shown in Fig 1.8.

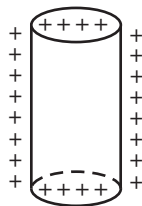

Fig. 1.8

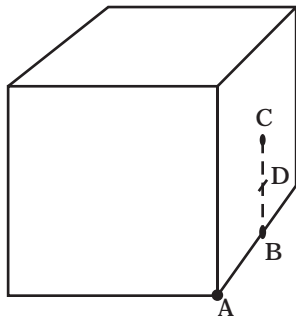

Fig. 1.9

1.19 What will be the total flux through the faces of the cube (Fig. 1.9) with side of length a if a charge q is placed at

- A: a corner of the cube.
- B: mid-point of an edge of the cube.
- C: centre of a face of the cube.
- D: mid-point of B and C.

S.A

1.20 A paisa coin is made up of Al-Mg alloy and weighs 0.75g. It has a square shape and its diagonal measures 17 mm. It is electrically neutral and contains equal amounts of positive and negative charges.

Treating the paisa coins made up of only Al, find the magnitude of equal number of positive and negative charges. What conclusion do you draw from this magnitude?

1.21 Consider a coin of Example 1.20. It is electrically neutral and contains equal amounts of positive and negative charge of magnitude 34.8 kC. Suppose that these equal charges were concentrated in two point charges separated by (i) 1 cm

$\left(\sim \frac{1}{2} \times \text{diagonal of the one paisa coin} \right)$, (ii) 100 m (\sim length of a long building), and (iii) 10^6 m (radius of the earth). Find the force on each such point charge in each of the three cases. What do you conclude from these results?

1.22 Fig. 1.10 represents a crystal unit of cesium chloride, CsCl. The cesium atoms, represented by open circles are situated at the corners of a cube of side 0.40nm, whereas a Cl atom is situated at the centre of the cube. The Cs atoms are deficient in one electron while the Cl atom carries an excess electron.

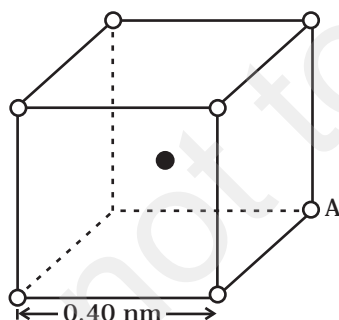

Fig. 1.10

- What is the net electric field on the Cl atom due to eight Cs atoms?
- Suppose that the Cs atom at the corner A is missing. What is the net force now on the Cl atom due to seven remaining Cs atoms?

1.23 Two charges q and $-3q$ are placed fixed on x-axis separated by distance ' d '. Where should a third charge $2q$ be placed such that it will not experience any force?

1.24 Fig. 1.11 shows the electric field lines around three point charges A, B and C.



Fig. 1.11

- Which charges are positive?
- Which charge has the largest magnitude? Why?
- In which region or regions of the picture could the electric field be zero? Justify your answer.
 - near A, (ii) near B, (iii) near C, (iv) nowhere.

1.25 Five charges, q each are placed at the corners of a regular pentagon of side 'a' (Fig. 1.12).

- What will be the electric field at O, the centre of the pentagon?
 - What will be the electric field at O if the charge from one of the corners (say A) is removed?
 - What will be the electric field at O if the charge q at A is replaced by $-q$?
- How would your answer to (a) be affected if pentagon is replaced by n-sided regular polygon with charge q at each of its corners?

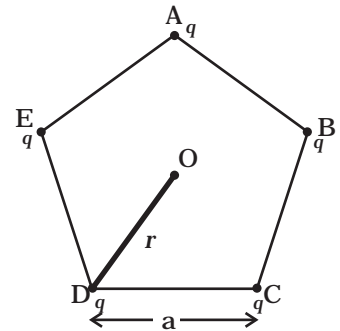

Fig. 1.12

LA

1.26 In 1959 Lyttleton and Bondi suggested that the expansion of the Universe could be explained if matter carried a net charge. Suppose that the Universe is made up of hydrogen atoms with a number density N , which is maintained a constant. Let the charge on the proton be: $e_p = -(1 + y)e$ where e is the electronic charge.

- Find the critical value of y such that expansion may start.
- Show that the velocity of expansion is proportional to the distance from the centre.

1.27 Consider a sphere of radius R with charge density distributed as

$$\rho(r) = kr \quad \text{for } r \leq R$$

$$= 0 \quad \text{for } r > R.$$

- (a) Find the electric field at all points r .
 (b) Suppose the total charge on the sphere is $2e$ where e is the electron charge. Where can two protons be embedded such that the force on each of them is zero. Assume that the introduction of the proton does not alter the negative charge distribution.

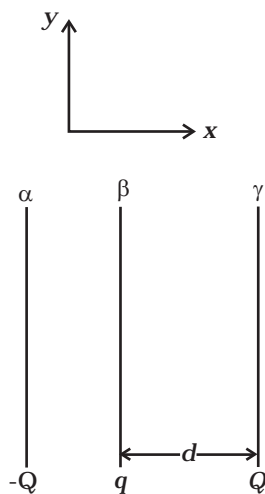

Fig. 1.13

1.28 Two fixed, identical conducting plates (α & β), each of surface area S are charged to $-Q$ and q , respectively, where $Q > q > 0$. A third identical plate (γ), free to move is located on the other side of the plate with charge q at a distance d (Fig 1.13). The third plate is released and collides with the plate β . Assume the collision is elastic and the time of collision is sufficient to redistribute charge amongst β & γ .

- (a) Find the electric field acting on the plate γ before collision.
 (b) Find the charges on β and γ after the collision.
 (c) Find the velocity of the plate γ after the collision and at a distance d from the plate β .

1.29 There is another useful system of units, besides the SI/mks A system, called the cgs (centimeter-gram-second) system. In this system Coloumb's law is given by

$$\mathbf{F} = \frac{Qq}{r^2} \hat{\mathbf{r}}$$

where the distance r is measured in cm ($= 10^{-2}$ m), F in dynes ($= 10^{-5}$ N) and the charges in electrostatic units (esu units), where

$$1 \text{ es unit of charge} = \frac{1}{[3]} \times 10^{-9} \text{ C}$$

The number [3] actually arises from the speed of light in vaccum which is now taken to be exactly given by $c = 2.99792458 \times 10^8$ m/s. An approximate value of c then is $c = [3] \times 10^8$ m/s.

- (i) Show that the coloumb law in cgs units yields

$$1 \text{ esu of charge} = 1 \text{ (dyne)}^{1/2} \text{ cm.}$$

Obtain the dimensions of units of charge in terms of mass M , length L and time T . Show that it is given in terms of fractional powers of M and L .

- (ii) Write 1 esu of charge = x C, where x is a dimensionless number. Show that this gives

$$\frac{1}{4\pi \epsilon_0} = \frac{10^{-9} \text{ N.m}^2}{x^2 \text{ C}^2}$$

With $x = \frac{1}{[3]} \times 10^{-9}$, we have

$$\frac{1}{4\pi \epsilon_0} = [3]^2 \times 10^9 \frac{\text{Nm}^2}{\text{C}^2}$$

$$\text{or, } \frac{1}{4\pi \epsilon_0} = (2.99792458)^2 \times 10^9 \frac{\text{Nm}^2}{\text{C}^2} \text{ (exactly).}$$

- 1.30** Two charges $-q$ each are fixed separated by distance $2d$. A third charge q of mass m placed at the mid-point is displaced slightly by x ($x \ll d$) perpendicular to the line joining the two fixed charged as shown in Fig. 1.14. Show that q will perform simple harmonic oscillation of time period.

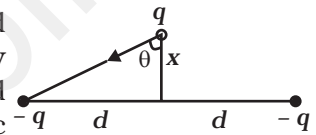

Fig. 1.14

$$T = \left[\frac{8\pi^3 \epsilon_0 m d^3}{q^2} \right]^{1/2}$$

- 1.31** Total charge $-Q$ is uniformly spread along length of a ring of radius R . A small test charge $+q$ of mass m is kept at the centre of the ring and is given a gentle push along the axis of the ring.
- (a) Show that the particle executes a simple harmonic oscillation.
 (b) Obtain its time period.

Chapter Two

ELECTROSTATIC POTENTIAL AND CAPACITANCE



MCQ I

2.1 A capacitor of $4 \mu\text{F}$ is connected as shown in the circuit (Fig. 2.1). The internal resistance of the battery is 0.5Ω . The amount of charge on the capacitor plates will be

- (a) 0
- (b) $4 \mu\text{C}$
- (c) $16 \mu\text{C}$
- (d) $8 \mu\text{C}$

2.2 A positively charged particle is released from rest in an uniform electric field. The electric potential energy of the charge

- (a) remains a constant because the electric field is uniform.
- (b) increases because the charge moves along the electric field.
- (c) decreases because the charge moves along the electric field.
- (d) decreases because the charge moves opposite to the electric field.

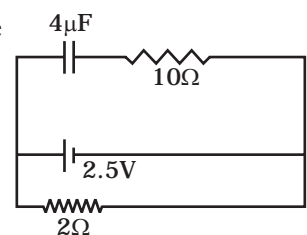
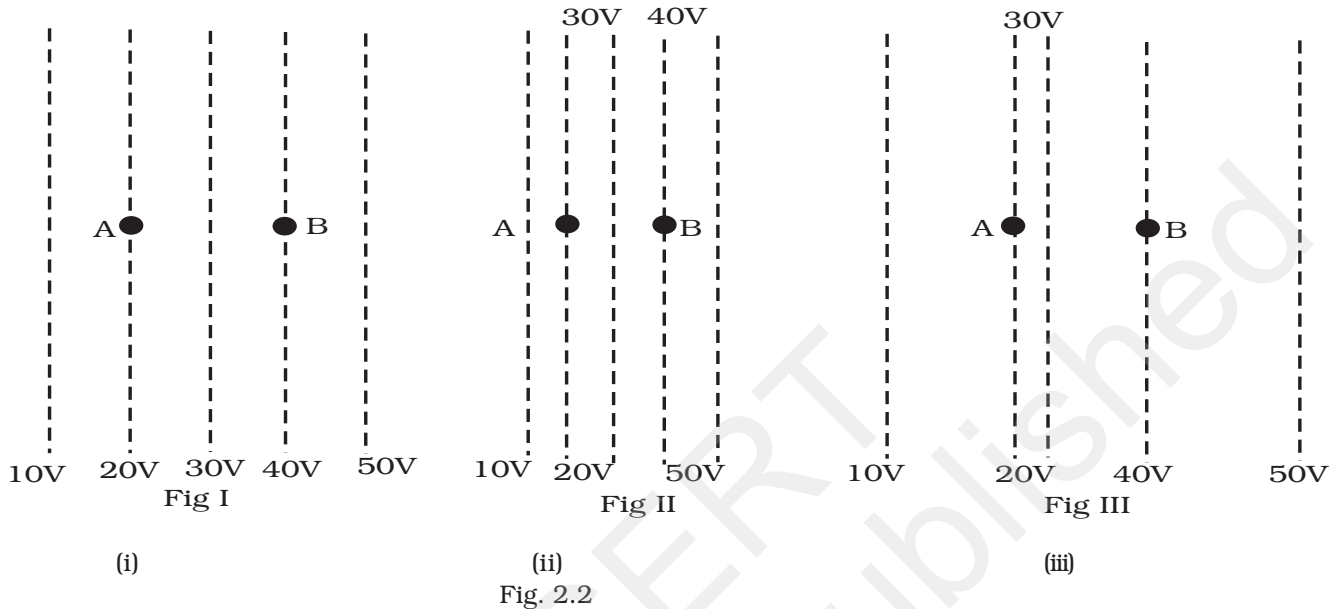

Fig. 2.1

2.3 Figure 2.2 shows some equipotential lines distributed in space. A charged object is moved from point A to point B.



- (i) (ii) (iii)
- Fig. 2.2
- (a) The work done in Fig. (i) is the greatest.
 (b) The work done in Fig. (ii) is least.
 (c) The work done is the same in Fig. (i), Fig. (ii) and Fig. (iii).
 (d) The work done in Fig. (iii) is greater than Fig. (ii) but equal to that in Fig. (i).

2.4 The electrostatic potential on the surface of a charged conducting sphere is 100V. Two statements are made in this regard:

- S_1 : At any point inside the sphere, electric intensity is zero.
 S_2 : At any point inside the sphere, the electrostatic potential is 100V.

Which of the following is a correct statement?

- (a) S_1 is true but S_2 is false.
 (b) Both S_1 & S_2 are false.
 (c) S_1 is true, S_2 is also true and S_1 is the cause of S_2 .
 (d) S_1 is true, S_2 is also true but the statements are independent.

2.5 Equipotentials at a great distance from a collection of charges whose total sum is not zero are approximately

- (a) spheres.
 (b) planes.
 (c) paraboloids
 (d) ellipsoids.

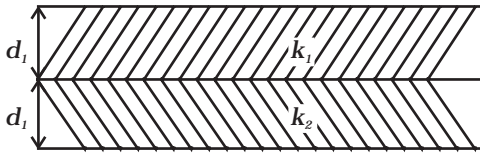

Fig. 2.3

2.6 A parallel plate capacitor is made of two dielectric blocks in series. One of the blocks has thickness d_1 and dielectric constant k_1 and the other has thickness d_2 and dielectric constant k_2 as shown in Fig. 2.3. This arrangement can be thought as a dielectric slab of thickness $d (= d_1 + d_2)$ and effective dielectric constant k . The k is

- (a) $\frac{k_1 d_1 + k_2 d_2}{d_1 + d_2}$ (b) $\frac{k_1 d_1 + k_2 d_2}{k_1 + k_2}$ (c) $\frac{k_1 k_2 (d_1 + d_2)}{(k_1 d_1 + k_2 d_2)}$ (d) $\frac{2k_1 k_2}{k_1 + k_2}$

MCQ II

2.7 Consider a uniform electric field in the \hat{z} direction. The potential is a constant

- (a) in all space.
 (b) for any x for a given z .
 (c) for any y for a given z .
 (d) on the x - y plane for a given z .

2.8 Equipotential surfaces

- (a) are closer in regions of large electric fields compared to regions of lower electric fields.
 (b) will be more crowded near sharp edges of a conductor.
 (c) will be more crowded near regions of large charge densities.
 (d) will always be equally spaced.

2.9 The work done to move a charge along an equipotential from A to B

(a) cannot be defined as $-\int_A^B \mathbf{E} \cdot d\mathbf{l}$

(b) must be defined as $-\int_A^B \mathbf{E} \cdot d\mathbf{l}$

(c) is zero.

(d) can have a non-zero value.

2.10 In a region of constant potential

- (a) the electric field is uniform
 (b) the electric field is zero
 (c) there can be no charge inside the region.
 (d) the electric field shall necessarily change if a charge is placed outside the region.

2.11 In the circuit shown in Fig. 2.4. initially key K_1 is closed and key

K_2 is open. Then K_1 is opened and K_2 is closed (order is important). [Take Q_1' and Q_2' as charges on C_1 and C_2 and V_1 and V_2 as voltage respectively.]

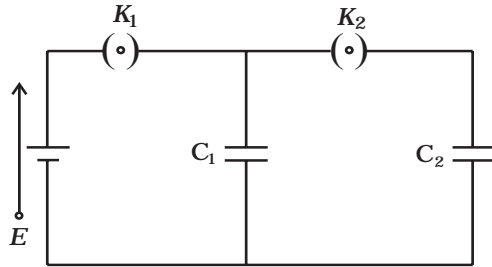

Fig. 2.4

Then

- (a) charge on C_1 gets redistributed such that $V_1 = V_2$
- (b) charge on C_1 gets redistributed such that $Q_1' = Q_2'$
- (c) charge on C_1 gets redistributed such that $C_1 V_1 + C_2 V_2 = C_1 E$
- (d) charge on C_1 gets redistributed such that $Q_1' + Q_2' = Q$

2.12 If a conductor has a potential $V \neq 0$ and there are no charges anywhere else outside, then

- (a) there must be charges on the surface or inside itself.
- (b) there cannot be any charge in the body of the conductor.
- (c) there must be charges only on the surface.
- (d) there must be charges inside the surface.

2.13 A parallel plate capacitor is connected to a battery as shown in Fig. 2.5. Consider two situations:

- A: Key K is kept closed and plates of capacitors are moved apart using insulating handle.
- B: Key K is opened and plates of capacitors are moved apart using insulating handle.

Choose the correct option(s).

- (a) In A : Q remains same but C changes.
- (b) In B : V remains same but C changes.
- (c) In A : V remains same and hence Q changes.
- (d) In B : Q remains same and hence V changes.

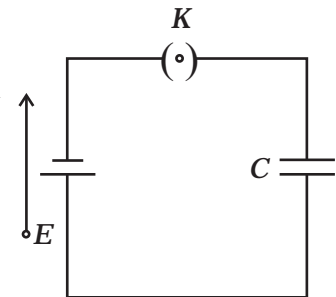

Fig. 2.5

VSA

2.14 Consider two conducting spheres of radii R_1 and R_2 with $R_1 > R_2$. If the two are at the same potential, the larger sphere has more charge than the smaller sphere. State whether the charge density of the

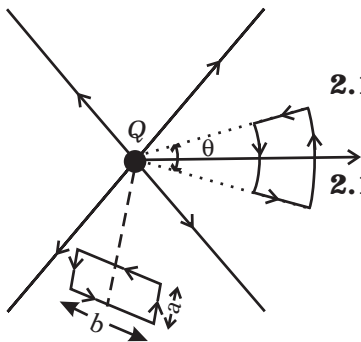

Fig. 2.6

smaller sphere is more or less than that of the larger one.

2.15 Do free electrons travel to region of higher potential or lower potential?

2.16 Can there be a potential difference between two adjacent conductors carrying the same charge?

2.17 Can the potential function have a maximum or minimum in free space?

2.18 A test charge q is made to move in the electric field of a point charge Q along two different closed paths (Fig. 2.6). First path has sections along and perpendicular to lines of electric field. Second path is a rectangular loop of the same area as the first loop. How does the work done compare in the two cases?

SA

2.19 Prove that a closed equipotential surface with no charge within itself must enclose an equipotential volume.

2.20 A capacitor has some dielectric between its plates, and the capacitor is connected to a DC source. The battery is now disconnected and then the dielectric is removed. State whether the capacitance, the energy stored in it, electric field, charge stored and the voltage will increase, decrease or remain constant.

2.21 Prove that, if an insulated, uncharged conductor is placed near a charged conductor and no other conductors are present, the uncharged body must be intermediate in potential between that of the charged body and that of infinity.

2.22 Calculate potential energy of a point charge $-q$ placed along the axis due to a charge $+Q$ uniformly distributed along a ring of radius R . Sketch P.E. as a function of axial distance z from the centre of the ring. Looking at graph, can you see what would happen if $-q$ is displaced slightly from the centre of the ring (along the axis)?

2.23 Calculate potential on the axis of a ring due to charge Q uniformly distributed along the ring of radius R .

LA

2.24 Find the equation of the equipotentials for an infinite cylinder of radius r_0 , carrying charge of linear density λ .

- 2.25** Two point charges of magnitude $+q$ and $-q$ are placed at $(-d/2, 0, 0)$ and $(d/2, 0, 0)$, respectively. Find the equation of the equipotential surface where the potential is zero.
- 2.26** A parallel plate capacitor is filled by a dielectric whose relative permittivity varies with the applied voltage (U) as $\epsilon = \alpha U$ where $\alpha = 2V^{-1}$. A similar capacitor with no dielectric is charged to $U_0 = 78$ V. It is then connected to the uncharged capacitor with the dielectric. Find the final voltage on the capacitors.
- 2.27** A capacitor is made of two circular plates of radius R each, separated by a distance $d \ll R$. The capacitor is connected to a constant voltage. A thin conducting disc of radius $r \ll R$ and thickness $t \ll r$ is placed at a centre of the bottom plate. Find the minimum voltage required to lift the disc if the mass of the disc is m .
- 2.28** (a) In a quark model of elementary particles, a neutron is made of one up quarks [charge $(2/3)e$] and two down quarks [charges $-(1/3)e$]. Assume that they have a triangle configuration with side length of the order of 10^{-15} m. Calculate electrostatic potential energy of neutron and compare it with its mass 939 MeV.
- (b) Repeat above exercise for a proton which is made of two up and one down quark.
- 2.29** Two metal spheres, one of radius R and the other of radius $2R$, both have same surface charge density σ . They are brought in contact and separated. What will be new surface charge densities on them?

- 2.30** In the circuit shown in Fig. 2.7, initially K_1 is closed and K_2 is open. What are the charges on each capacitors. Then K_1 was opened and K_2 was closed (order is important), What will be the charge on each capacitor now? [$C = 1\mu\text{F}$]

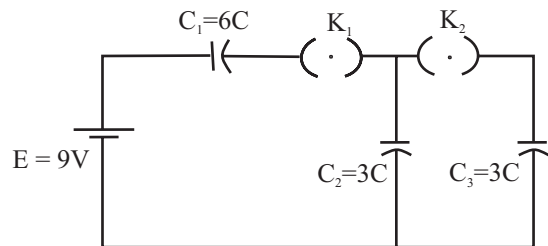

Fig. 2.7

- 2.31** Calculate potential on the axis of a disc of radius R due to a charge Q uniformly distributed on its surface.
- 2.32** Two charges q_1 and q_2 are placed at $(0, 0, d)$ and $(0, 0, -d)$ respectively. Find locus of points where the potential a zero.
- 2.33** Two charges $-q$ each are separated by distance $2d$. A third charge $+q$ is kept at mid point O. Find potential energy of $+q$ as a function of small distance x from O due to $-q$ charges. Sketch P.E. v/s x and convince yourself that the charge at O is in an unstable equilibrium.

Chapter Three

CURRENT ELECTRICITY



MCQ I

- 3.1** Consider a current carrying wire (current I) in the shape of a circle. Note that as the current progresses along the wire, the direction of \mathbf{j} (current density) changes in an exact manner, while the current I remain unaffected. The agent that is *essentially* responsible for is
- (a) source of emf.
 - (b) electric field produced by charges accumulated on the surface of wire.
 - (c) the charges just behind a given segment of wire which push them just the right way by repulsion.
 - (d) the charges ahead.
- 3.2** Two batteries of emf ε_1 and ε_2 ($\varepsilon_2 > \varepsilon_1$) and internal resistances r_1 and r_2 respectively are connected in parallel as shown in Fig 3.1.
- (a) The equivalent emf ε_{eq} of the two cells is between ε_1 and ε_2 , i.e. $\varepsilon_1 < \varepsilon_{\text{eq}} < \varepsilon_2$.

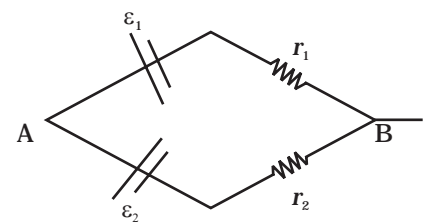

Fig 3.1

- (b) The equivalent emf ε_{eq} is smaller than ε_1 .
- (c) The ε_{eq} is given by $\varepsilon_{\text{eq}} = \varepsilon_1 + \varepsilon_2$ always.
- (d) ε_{eq} is independent of internal resistances r_1 and r_2 .
- 3.3** A resistance R is to be measured using a meter bridge. Student chooses the standard resistance S to be 100Ω . He finds the null point at $l_1 = 2.9$ cm. He is told to attempt to improve the accuracy. Which of the following is a useful way?
- (a) He should measure l_1 more accurately.
- (b) He should change S to 1000Ω and repeat the experiment.
- (c) He should change S to 3Ω and repeat the experiment.
- (d) He should give up hope of a more accurate measurement with a meter bridge.
- 3.4** Two cells of emf's approximately 5V and 10V are to be accurately compared using a potentiometer of length 400cm.
- (a) The battery that runs the potentiometer should have voltage of 8V.
- (b) The battery of potentiometer can have a voltage of 15V and R adjusted so that the potential drop across the wire slightly exceeds 10V.
- (c) The first portion of 50 cm of wire itself should have a potential drop of 10V.
- (d) Potentiometer is usually used for comparing resistances and not voltages.
- 3.5** A metal rod of length 10 cm and a rectangular cross-section of $1\text{ cm} \times \frac{1}{2}$ cm is connected to a battery across opposite faces. The resistance will be
- (a) maximum when the battery is connected across $1\text{ cm} \times \frac{1}{2}$ cm faces.
- (b) maximum when the battery is connected across $10\text{ cm} \times 1\text{ cm}$ faces.
- (c) maximum when the battery is connected across $10\text{ cm} \times \frac{1}{2}$ cm faces.
- (d) same irrespective of the three faces.
- 3.6** Which of the following characteristics of electrons determines the current in a conductor?
- (a) Drift velocity alone.
- (b) Thermal velocity alone.
- (c) Both drift velocity and thermal velocity.
- (d) Neither drift nor thermal velocity.

MCQ II

3.7 Kirchhoff's junction rule is a reflection of

- conservation of current density vector.
- conservation of charge.
- the fact that the momentum with which a charged particle approaches a junction is unchanged (as a vector) as the charged particle leaves the junction.
- the fact that there is no accumulation of charges at a junction.

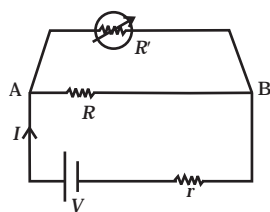



Fig 3.2

3.8 Consider a simple circuit shown in Fig 3.2.  stands for a variable resistance R' . R' can vary from R_0 to infinity. r is internal resistance of the battery ($r \ll R \ll R_0$).

- Potential drop across AB is nearly constant as R' is varied.
- Current through R' is nearly a constant as R' is varied.
- Current I depends sensitively on R' .
- $I \geq \frac{V}{r + R}$ always.

3.9 Temperature dependence of resistivity $\rho(T)$ of semiconductors, insulators and metals is significantly based on the following factors:

- number of charge carriers can change with temperature T .
- time interval between two successive collisions can depend on T .
- length of material can be a function of T .
- mass of carriers is a function of T .

3.10 The measurement of an unknown resistance R is to be carried out using Wheatstones bridge (see Fig. 3.25 of NCERT Book). Two students perform an experiment in two ways. The first student takes $R_2 = 10\Omega$ and $R_1 = 5\Omega$. The other student takes $R_2 = 1000\Omega$ and $R_1 = 500\Omega$. In the standard arm, both take $R_3 = 5\Omega$.

Both find $R = \frac{R_2}{R_1} R_3 = 10\Omega$ within errors.

- The errors of measurement of the two students are the same.
- Errors of measurement do depend on the accuracy with which R_2 and R_1 can be measured.
- If the student uses large values of R_2 and R_1 , the currents through the arms will be feeble. This will make determination of null point accurately more difficult.
- Wheatstone bridge is a very accurate instrument and has no errors of measurement.

- 3.11** In a meter bridge the point D is a neutral point (Fig 3.3).
- The meter bridge can have no other neutral point for this set of resistances.
 - When the jockey contacts a point on meter wire left of D, current flows to B from the wire.
 - When the jockey contacts a point on the meter wire to the right of D, current flows from B to the wire through galvanometer.
 - When R is increased, the neutral point shifts to left.

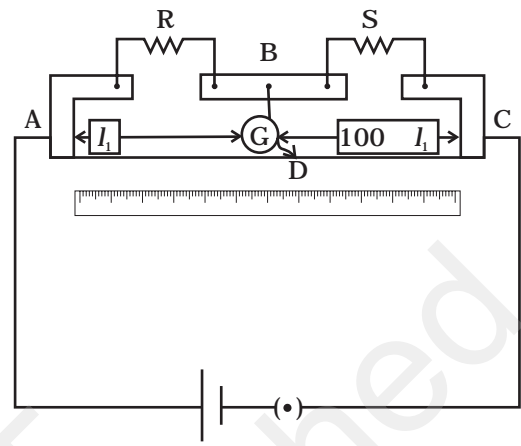

Fig 3.3

VSA

- 3.12** Is the motion of a charge across junction momentum conserving? Why or why not?
- 3.13** The relaxation time τ is nearly independent of applied E field whereas it changes significantly with temperature T . First fact is (in part) responsible for Ohm's law whereas the second fact leads to variation of ρ with temperature. Elaborate why?
- 3.14** What are the advantages of the null-point method in a Wheatstone bridge? What additional measurements would be required to calculate R_{unknown} by any other method?
- 3.15** What is the advantage of using thick metallic strips to join wires in a potentiometer?
- 3.16** For wiring in the home, one uses Cu wires or Al wires. What considerations are involved in this?
- 3.17** Why are alloys used for making standard resistance coils?
- 3.18** Power P is to be delivered to a device via transmission cables having resistance R_c . If V is the voltage across R and I the current through it, find the power wasted and how can it be reduced.
- 3.19** AB is a potentiometer wire (Fig 3.4). If the value of R is increased, in which direction will the balance point J shift?

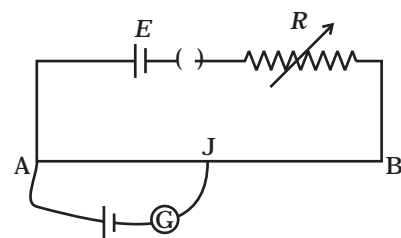

Fig 3.4

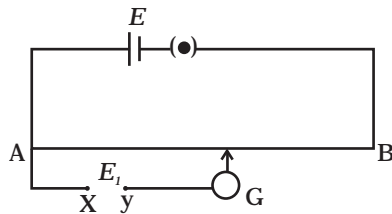

Fig 3.5

3.20 While doing an experiment with potentiometer (Fig 3.5) it was found that the deflection is one sided and (i) the deflection decreased while moving from one end A of the wire to the end B; (ii) the deflection increased. while the jockey was moved towards the end B.

- (i) Which terminal +or -ve of the cell E_1 , is connected at X in case (i) and how is E_1 related to E ?
- (ii) Which terminal of the cell E_1 is connected at X in case (ii)?

3.21 A cell of emf E and internal resistance r is connected across an external resistance R . Plot a graph showing the variation of P.D. across R , versus R .

SA

3.22 First a set of n equal resistors of R each are connected in series to a battery of emf E and internal resistance R . A current I is observed to flow. Then the n resistors are connected in parallel to the same battery. It is observed that the current is increased 10 times. What is 'n'?

3.23 Let there be n resistors R_1, \dots, R_n with $R_{\max} = \max (R_1, \dots, R_n)$ and $R_{\min} = \min \{R_1, \dots, R_n\}$. Show that when they are connected in parallel, the resultant resistance $R_p < R_{\min}$ and when they are connected in series, the resultant resistance $R_s > R_{\max}$. Interpret the result physically.

3.24 The circuit in Fig 3.6 shows two cells connected in opposition to each other. Cell E_1 is of emf 6V and internal resistance 2Ω ; the cell E_2 is of emf 4V and internal resistance 8Ω . Find the potential difference between the points A and B.

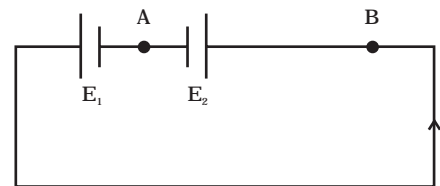

Fig 3.6

3.25 Two cells of same emf E but internal resistance r_1 and r_2 are connected in series to an external resistor R (Fig 3.7). What should be the value of R so that the potential difference across the terminals of the first cell becomes zero.

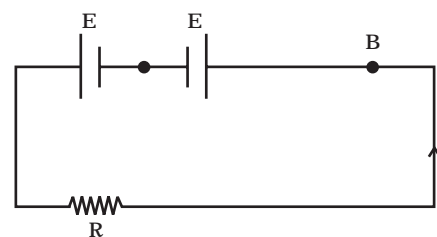

Fig. 3.7

- 3.26** Two conductors are made of the same material and have the same length. Conductor A is a solid wire of diameter 1mm. Conductor B is a hollow tube of outer diameter 2mm and inner diameter 1mm. Find the ratio of resistance R_A to R_B .
- 3.27** Suppose there is a circuit consisting of only resistances and batteries. Suppose one is to double (or increase it to n -times) all voltages and all resistances. Show that currents are unaltered. Do this for circuit of Example 3.7 in the NCERT Text Book for Class XII.

LA

- 3.28** Two cells of voltage 10V and 2V and internal resistances 10Ω and 5Ω respectively, are connected in parallel with the positive end of 10V battery connected to negative pole of 2V battery (Fig 3.8). Find the effective voltage and effective resistance of the combination.

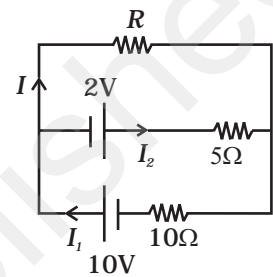

Fig 3.8

- 3.29** A room has AC run for 5 hours a day at a voltage of 220V. The wiring of the room consists of Cu of 1 mm radius and a length of 10 m. Power consumption per day is 10 commercial units. What fraction of it goes in the joule heating in wires? What would happen if the wiring is made of aluminium of the same dimensions?

$[\rho_{cu} = 1.7 \times 10^{-8} \Omega m, \rho_{Al} = 2.7 \times 10^{-8} \Omega m]$

- 3.30** In an experiment with a potentiometer, $V_B = 10V$. R is adjusted to be 50Ω (Fig. 3.9). A student wanting to measure voltage E_1 of a battery (approx. 8V) finds no null point possible. He then diminishes R to 10Ω and is able to locate the null point on the last (4th) segment of the potentiometer. Find the resistance of the potentiometer wire and potential drop per unit length across the wire in the second case.

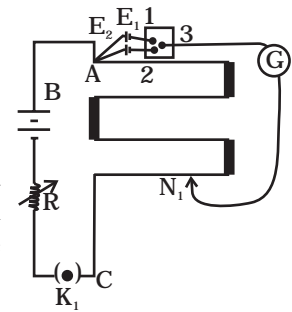

Fig 3.9

- 3.31** (a) Consider circuit in Fig 3.10. How much energy is absorbed by electrons from the initial state of no current (ignore thermal motion) to the state of drift velocity?
- (b) Electrons give up energy at the rate of RI^2 per second to the thermal energy. What time scale would one associate with energy in problem (a)? n = no of electron/volume = $10^{29}/m^3$, length of circuit = 10 cm, cross-section = $A = (1mm)^2$

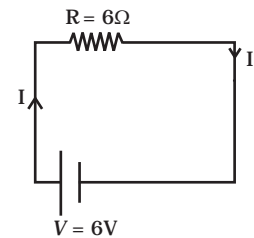

Fig 3.10

Chapter Four

MOVING CHARGES AND MAGNETISM



MCQ I

- 4.1** Two charged particles traverse *identical* helical paths in a completely opposite sense in a uniform magnetic field $\mathbf{B} = B_0 \hat{\mathbf{k}}$.
- (a) They have equal z-components of momenta.
 - (b) They must have equal charges.
 - (c) They necessarily represent a particle-antiparticle pair.
 - (d) The charge to mass ratio satisfy : $\left(\frac{e}{m}\right)_1 + \left(\frac{e}{m}\right)_2 = 0$.
- 4.2** Biot-Savart law indicates that the moving electrons (velocity \mathbf{v}) produce a magnetic field \mathbf{B} such that
- (a) $\mathbf{B} \perp \mathbf{v}$.
 - (b) $\mathbf{B} \parallel \mathbf{v}$.
 - (c) it obeys inverse cube law.
 - (d) it is along the line joining the electron and point of observation.

- 4.3** A current carrying circular loop of radius R is placed in the x - y plane with centre at the origin. Half of the loop with $x > 0$ is now bent so that it now lies in the y - z plane.
- The magnitude of magnetic moment now diminishes.
 - The magnetic moment does not change.
 - The magnitude of \mathbf{B} at $(0,0,z)$, $z \gg R$ increases.
 - The magnitude of \mathbf{B} at $(0,0,z)$, $z \gg R$ is unchanged.
- 4.4** An electron is projected with uniform velocity along the axis of a current carrying long solenoid. Which of the following is true?
- The electron will be accelerated along the axis.
 - The electron path will be circular about the axis.
 - The electron will experience a force at 45° to the axis and hence execute a helical path.
 - The electron will continue to move with uniform velocity along the axis of the solenoid.
- 4.5** In a cyclotron, a charged particle
- undergoes acceleration all the time.
 - speeds up between the dees because of the magnetic field.
 - speeds up in a dee.
 - slows down within a dee and speeds up between dees.
- 4.6** A circular current loop of magnetic moment M is in an arbitrary orientation in an external magnetic field \mathbf{B} . The work done to rotate the loop by 30° about an axis perpendicular to its plane is
- MB .
 - $\sqrt{3} \frac{MB}{2}$.
 - $\frac{MB}{2}$.
 - zero.

MCQ II

- 4.7** The gyro-magnetic ratio of an electron in an H-atom, according to Bohr model, is
- independent of which orbit it is in.
 - negative.
 - positive.
 - increases with the quantum number n .

4.8 Consider a wire carrying a steady current, I placed in a uniform magnetic field \mathbf{B} perpendicular to its length. Consider the charges inside the wire. It is known that magnetic forces do no work. This implies that,

- (a) motion of charges inside the conductor is unaffected by \mathbf{B} since they do not absorb energy.
- (b) some charges inside the wire move to the surface as a result of \mathbf{B} .
- (c) if the wire moves under the influence of \mathbf{B} , no work is done by the force.
- (d) if the wire moves under the influence of \mathbf{B} , no work is done by the magnetic force on the ions, assumed fixed within the wire.

4.9 Two identical current carrying coaxial loops, carry current I in an opposite sense. A simple amperian loop passes through both of them once. Calling the loop as C ,

- (a) $\oint_C \mathbf{B} \cdot d\mathbf{l} = m2\mu_0 I$.
- (b) the value of $\oint_C \mathbf{B} \cdot d\mathbf{l}$ is independent of sense of C .
- (c) there may be a point on C where \mathbf{B} and $d\mathbf{l}$ are perpendicular.
- (d) \mathbf{B} vanishes everywhere on C .

4.10 A cubical region of space is filled with some uniform electric and magnetic fields. An electron enters the cube across one of its faces with velocity \mathbf{v} and a positron enters via opposite face with velocity $-\mathbf{v}$. At this instant,

- (a) the electric forces on both the particles cause identical accelerations.
- (b) the magnetic forces on both the particles cause equal accelerations.
- (c) both particles gain or loose energy at the same rate.
- (d) the motion of the centre of mass (CM) is determined by \mathbf{B} alone.

4.11 A charged particle would continue to move with a constant velocity in a region wherein,

- (a) $\mathbf{E} = 0, \mathbf{B} \neq 0$.
- (b) $\mathbf{E} \neq 0, \mathbf{B} \neq 0$.
- (c) $\mathbf{E} \neq 0, \mathbf{B} = 0$.
- (d) $\mathbf{E} = 0, \mathbf{B} = 0$.

VSA

- 4.12 Verify that the cyclotron frequency $\omega = eB/m$ has the correct dimensions of $[T]^{-1}$.
- 4.13 Show that a force that does no work must be a velocity dependent force.
- 4.14 The magnetic force depends on \mathbf{v} which depends on the inertial frame of reference. Does then the magnetic force differ from inertial frame to frame? Is it reasonable that the net acceleration has a different value in different frames of reference?
- 4.15 Describe the motion of a charged particle in a cyclotron if the frequency of the radio frequency (rf) field were doubled.
- 4.16 Two long wires carrying current I_1 and I_2 are arranged as shown in Fig. 4.1. The one carrying current I_1 is along the x -axis. The other carrying current I_2 is along a line parallel to the y -axis given by $x = 0$ and $z = d$. Find the force exerted at O_2 because of the wire along the x -axis.

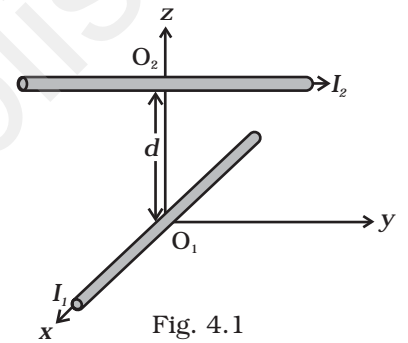

Fig. 4.1

SA

- 4.17 A current carrying loop consists of 3 identical quarter circles of radius R , lying in the positive quadrants of the x - y , y - z and z - x planes with their centres at the origin, joined together. Find the direction and magnitude of \mathbf{B} at the origin.
- 4.18 A charged particle of charge e and mass m is moving in an electric field \mathbf{E} and magnetic field \mathbf{B} . Construct dimensionless quantities and quantities of dimension $[T]^{-1}$.
- 4.19 An electron enters with a velocity $\mathbf{v} = v_0 \hat{\mathbf{i}}$ into a cubical region (faces parallel to coordinate planes) in which there are uniform electric and magnetic fields. The orbit of the electron is found to spiral down inside the cube in plane parallel to the x - y plane. Suggest a configuration of fields \mathbf{E} and \mathbf{B} that can lead to it.
- 4.20 Do magnetic forces obey Newton's third law. Verify for two current elements $d\mathbf{l}_1 = dl \hat{\mathbf{i}}$ located at the origin and $d\mathbf{l}_2 = dl \hat{\mathbf{j}}$ located at $(0, R, 0)$. Both carry current I .

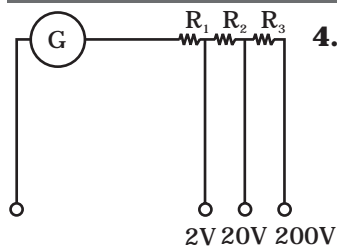

Fig. 4.2

- 4.21** A multirange voltmeter can be constructed by using a galvanometer circuit as shown in Fig. 4.2. We want to construct a voltmeter that can measure 2V, 20V and 200V using a galvanometer of resistance 10Ω and that produces maximum deflection for current of 1 mA. Find R_1 , R_2 and R_3 that have to be used.

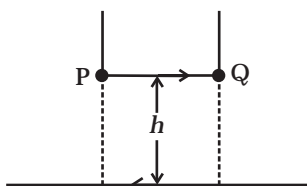

Fig. 4.3

- 4.22** A long straight wire carrying current of 25A rests on a table as shown in Fig. 4.3. Another wire PQ of length 1m, mass 2.5 g carries the same current but in the opposite direction. The wire PQ is free to slide up and down. To what height will PQ rise?

LA

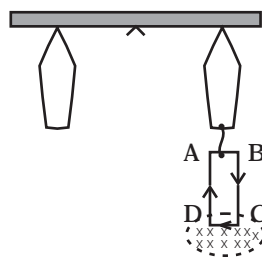

Fig. 4.4

- 4.23** A 100 turn rectangular coil ABCD (in XY plane) is hung from one arm of a balance (Fig. 4.4). A mass 500g is added to the other arm to balance the weight of the coil. A current 4.9 A passes through the coil and a constant magnetic field of 0.2 T acting inward (in xz plane) is switched on such that only arm CD of length 1 cm lies in the field. How much additional mass 'm' must be added to regain the balance?

- 4.24** A rectangular conducting loop consists of two wires on two opposite sides of length l joined together by rods of length d . The wires are each of the same material but with cross-sections differing by a factor of 2. The thicker wire has a resistance R and the rods are of low resistance, which in turn are connected to a constant voltage source V_0 . The loop is placed in uniform a magnetic field \mathbf{B} at 45° to its plane. Find τ , the torque exerted by the magnetic field on the loop about an axis through the centres of rods.

- 4.25** An electron and a positron are released from $(0, 0, 0)$ and $(0, 0, 1.5R)$ respectively, in a uniform magnetic field $\mathbf{B} = B_0\hat{i}$, each with an equal momentum of magnitude $p = eBR$. Under what conditions on the direction of momentum will the orbits be non-intersecting circles?

- 4.26** A uniform conducting wire of length $12a$ and resistance R is wound up as a current carrying coil in the shape of (i) an equilateral triangle of side a ; (ii) a square of sides a and, (iii) a regular hexagon of sides a . The coil is connected to a voltage source V_0 . Find the magnetic moment of the coils in each case.

4.27 Consider a circular current-carrying loop of radius R in the x - y plane with centre at origin. Consider the line integral

$$\mathfrak{I}(L) = \left| \int_{-L}^L \mathbf{B} \cdot d\mathbf{l} \right| \text{ taken along } z\text{-axis.}$$

- (a) Show that $\mathfrak{I}(L)$ monotonically increases with L .
- (b) Use an appropriate Amperian loop to show that $\mathfrak{I}(\infty) = \mu_0 I$, where I is the current in the wire.
- (c) Verify directly the above result.
- (d) Suppose we replace the circular coil by a square coil of sides R carrying the same current I . What can you say about $\mathfrak{I}(L)$ and $\mathfrak{I}(\infty)$?

4.28 A multirange current meter can be constructed by using a galvanometer circuit as shown in Fig. 4.5. We want a current meter that can measure 10mA, 100mA and 1A using a galvanometer of resistance 10Ω and that produces maximum deflection for current of 1mA. Find S_1 , S_2 and S_3 that have to be used

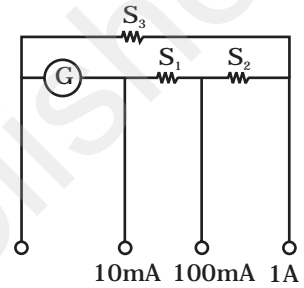

Fig. 4.5

4.29 Five long wires A, B, C, D and E, each carrying current I are arranged to form edges of a pentagonal prism as shown in Fig. 4.6. Each carries current out of the plane of paper.

- (a) What will be magnetic induction at a point on the axis O ? Axis E is at a distance R from each wire.
- (b) What will be the field if current in one of the wires (say A) is switched off?
- (c) What if current in one of the wire (say) A is reversed?

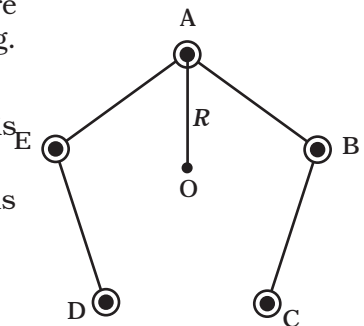

Fig. 4.6

Chapter Five

MAGNETISM AND MATTER



MCQ I

- 5.1** A toroid of n turns, mean radius R and cross-sectional radius a carries current I . It is placed on a horizontal table taken as x - y plane. Its magnetic moment \mathbf{m}
- (a) is non-zero and points in the z -direction by symmetry.
 - (b) points along the axis of the toroid ($\mathbf{m} = m\hat{\phi}$).
 - (c) is zero, otherwise there would be a field falling as $\frac{1}{r^3}$ at large distances outside the toroid.
 - (d) is pointing radially outwards.
- 5.2** The magnetic field of Earth can be modelled by that of a point dipole placed at the centre of the Earth. The dipole axis makes an angle of 11.3° with the axis of Earth. At Mumbai, declination is nearly zero. Then,
- (a) the declination varies between 11.3° W to 11.3° E.
 - (b) the least declination is 0° .

- (c) the plane defined by dipole axis and Earth axis passes through Greenwich.
- (d) declination averaged over Earth must be always negative.

5.3 In a permanent magnet at room temperature

- (a) magnetic moment of each molecule is zero.
- (b) the individual molecules have non-zero magnetic moment which are all perfectly aligned.
- (c) domains are partially aligned.
- (d) domains are all perfectly aligned.

5.4 Consider the two idealized systems: (i) a parallel plate capacitor with large plates and small separation and (ii) a long solenoid of length $L \gg R$, radius of cross-section. In (i) \mathbf{E} is ideally treated as a constant between plates and zero outside. In (ii) magnetic field is constant inside the solenoid and zero outside. These idealised assumptions, however, contradict fundamental laws as below:

- (a) case (i) contradicts Gauss's law for electrostatic fields.
- (b) case (ii) contradicts Gauss's law for magnetic fields.
- (c) case (i) agrees with $\oint \mathbf{E} \cdot d\mathbf{l} = 0$.
- (d) case (ii) contradicts $\oint \mathbf{H} \cdot d\mathbf{l} = I_{en}$.

5.5 A paramagnetic sample shows a net magnetisation of 8 Am^{-1} when placed in an external magnetic field of 0.6 T at a temperature of 4 K . When the same sample is placed in an external magnetic field of 0.2 T at a temperature of 16 K , the magnetisation will be

- (a) $\frac{32}{3} \text{ Am}^{-1}$
- (b) $\frac{2}{3} \text{ Am}^{-1}$
- (c) 6 Am^{-1}
- (d) 2.4 Am^{-1} .

MCQ II

5.6 S is the surface of a lump of magnetic material.

- (a) Lines of \mathbf{B} are necessarily continuous across S .
- (b) Some lines of \mathbf{B} must be discontinuous across S .
- (c) Lines of \mathbf{H} are necessarily continuous across S .
- (d) Lines of \mathbf{H} cannot all be continuous across S .

- 5.7** The primary origin(s) of magnetism lies in
- atomic currents.
 - Pauli exclusion principle.
 - polar nature of molecules.
 - intrinsic spin of electron.
- 5.8** A long solenoid has 1000 turns per metre and carries a current of 1 A. It has a soft iron core of $\mu_r = 1000$. The core is heated beyond the Curie temperature, T_c .
- The **H** field in the solenoid is (nearly) unchanged but the **B** field decreases drastically.
 - The **H** and **B** fields in the solenoid are nearly unchanged.
 - The magnetisation in the core reverses direction.
 - The magnetisation in the core diminishes by a factor of about 10^8 .
- 5.9** Essential difference between electrostatic shielding by a conducting shell and magnetostatic shielding is due to
- electrostatic field lines can end on charges and conductors have free charges.
 - lines of **B** can also end but conductors cannot end them.
 - lines of **B** cannot end on any material and perfect shielding is not possible.
 - shells of high permeability materials can be used to divert lines of **B** from the interior region.
- 5.10** Let the magnetic field on earth be modelled by that of a point magnetic dipole at the centre of earth. The angle of dip at a point on the geographical equator
- is always zero.
 - can be zero at specific points.
 - can be positive or negative.
 - is bounded.

VSA

- 5.11** A proton has spin and magnetic moment just like an electron. Why then its effect is neglected in magnetism of materials?
- 5.12** A permanent magnet in the shape of a thin cylinder of length 10 cm has $M = 10^6$ A/m. Calculate the magnetisation current I_M .
- 5.13** Explain quantitatively the order of magnitude difference between the diamagnetic susceptibility of N_2 ($\sim 5 \times 10^{-9}$) (at STP) and Cu ($\sim 10^{-5}$).

- 5.14** From molecular view point, discuss the temperature dependence of susceptibility for diamagnetism, paramagnetism and ferromagnetism.
- 5.15** A ball of superconducting material is dipped in liquid nitrogen and placed near a bar magnet. (i) In which direction will it move? (ii) What will be the direction of its magnetic moment?

SA

- 5.16** Verify the Gauss's law for magnetic field of a point dipole of dipole moment \mathbf{m} at the origin for the surface which is a sphere of radius R .
- 5.17** Three identical bar magnets are rivetted together at centre in the same plane as shown in Fig. 5.1. This system is placed at rest in a slowly varying magnetic field. It is found that the system of magnets does not show any motion. The north-south poles of one magnet is shown in the Fig. 5.1. Determine the poles of the remaining two.

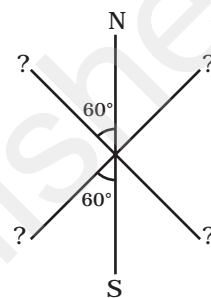

Fig. 5.1

- 5.18** Suppose we want to verify the analogy between electrostatic and magnetostatic by an explicit experiment. Consider the motion of (i) electric dipole \mathbf{p} in an electrostatic field \mathbf{E} and (ii) magnetic dipole \mathbf{m} in a magnetic field \mathbf{B} . Write down a set of conditions on \mathbf{E} , \mathbf{B} , \mathbf{p} , \mathbf{m} so that the two motions are verified to be identical. (Assume identical initial conditions.)
- 5.19** A bar magnet of magnetic moment m and moment of inertia I (about centre, perpendicular to length) is cut into two equal pieces, perpendicular to length. Let T be the period of oscillations of the original magnet about an axis through the mid point, perpendicular to length, in a magnetic field \mathbf{B} . What would be the similar period T' for each piece?
- 5.20** Use (i) the Ampere's law for \mathbf{H} and (ii) continuity of lines of \mathbf{B} , to conclude that inside a bar magnet, (a) lines of \mathbf{H} run from the N pole to S pole, while (b) lines of \mathbf{B} must run from the S pole to N pole.

LA

- 5.21** Verify the Ampere's law for magnetic field of a point dipole of dipole moment $\mathbf{m} = m\hat{\mathbf{k}}$. Take C as the closed curve running clockwise along (i) the z -axis from $z = a > 0$ to $z = R$; (ii) along the quarter circle of radius R and centre at the origin, in the first quadrant of x - z plane; (iii) along the x -axis from $x = R$ to $x = a$, and (iv) along the quarter circle of radius a and centre at the origin in the first quadrant of x - z plane.

5.22 What are the dimensions of χ , the magnetic susceptibility? Consider an H-atom. Guess an expression for χ , upto a constant by constructing a quantity of dimensions of χ , out of parameters of the atom: e , m , v , R and μ_0 . Here, m is the electronic mass, v is electronic velocity, R is Bohr radius. Estimate the number so obtained and compare with the value of $|\chi| \sim 10^{-5}$ for many solid materials.

5.23 Assume the dipole model for earth's magnetic field B which is given

$$\text{by } B_v = \text{vertical component of magnetic field} = \frac{\mu_0}{4\pi} \frac{2m \cos \theta}{r^3}$$

$$B_H = \text{Horizontal component of magnetic field} = \frac{\mu_0}{4\pi} \frac{\sin \theta m}{r^3}$$

$\theta = 90^\circ - \text{lattitude as measured from magnetic equator.}$

Find loci of points for which (i) $|\mathbf{B}|$ is minimum; (ii) dip angle is zero; and (iii) dip angle is $\pm 45^\circ$.

5.24 Consider the plane S formed by the dipole axis and the axis of earth. Let P be point on the magnetic equator and in S . Let Q be the point of intersection of the geographical and magnetic equators. Obtain the declination and dip angles at P and Q .

5.25 There are two current carrying planar coils made each from identical wires of length L . C_1 is circular (radius R) and C_2 is square (side a). They are so constructed that they have same frequency of oscillation when they are placed in the same uniform \mathbf{B} and carry the same current. Find a in terms of R .

Chapter Six

ELECTROMAGNETIC INDUCTION



MCQ 1

- 6.1** A square of side L meters lies in the x - y plane in a region, where the magnetic field is given by $\mathbf{B} = B_0(2\hat{\mathbf{i}} + 3\hat{\mathbf{j}} + 4\hat{\mathbf{k}})$ T, where B_0 is constant. The magnitude of flux passing through the square is
- (a) $2 B_0 L^2$ Wb.
 - (b) $3 B_0 L^2$ Wb.
 - (c) $4 B_0 L^2$ Wb.
 - (d) $\sqrt{29} B_0 L^2$ Wb.
- 6.2** A loop, made of straight edges has six corners at A(0,0,0), B(L,0,0) C(L,L,0), D(0,L,0) E(0,L,L) and F(0,0,L). A magnetic field $\mathbf{B} = B_0(\hat{\mathbf{i}} + \hat{\mathbf{k}})$ T is present in the region. The flux passing through the loop ABCDEFA (in that order) is
- (a) $B_0 L^2$ Wb.
 - (b) $2 B_0 L^2$ Wb.
 - (c) $\sqrt{2} B_0 L^2$ Wb.
 - (d) $4 B_0 L^2$ Wb.

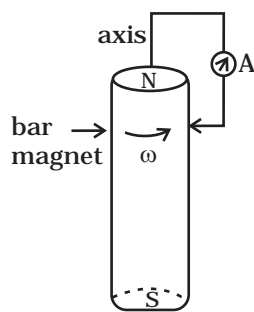

Fig. 6.1

6.3 A cylindrical bar magnet is rotated about its axis (Fig 6.1). A wire is connected from the axis and is made to touch the cylindrical surface through a contact. Then

- a direct current flows in the ammeter A.
- no current flows through the ammeter A.
- an alternating sinusoidal current flows through the ammeter A with a time period $T=2\pi/\omega$.
- a time varying non-sinusoidal current flows through the ammeter A.

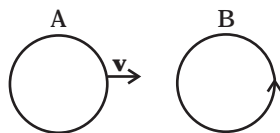

Fig. 6.2

6.4 There are two coils A and B as shown in Fig 6.2. A current starts flowing in B as shown, when A is moved towards B and stops when A stops moving. The current in A is counterclockwise. B is kept stationary when A moves. We can infer that

- there is a constant current in the clockwise direction in A.
- there is a varying current in A.
- there is no current in A.
- there is a constant current in the counterclockwise direction in A.

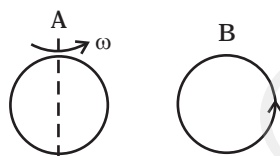

Fig. 6.3

6.5 Same as problem 4 except the coil A is made to rotate about a vertical axis (Fig 6.3). No current flows in B if A is at rest. The current in coil A, when the current in B (at $t = 0$) is counterclockwise and the coil A is as shown at this instant, $t = 0$, is

- constant current clockwise.
- varying current clockwise.
- varying current counterclockwise.
- constant current counterclockwise.

6.6 The self inductance L of a solenoid of length l and area of cross-section A , with a fixed number of turns N increases as

- l and A increase.
- l decreases and A increases.
- l increases and A decreases.
- both l and A decrease.

MCQ II

6.7 A metal plate is getting heated. It can be because

- a direct current is passing through the plate.
- it is placed in a time varying magnetic field.

- (c) it is placed in a space varying magnetic field, but does not vary with time.
- (d) a current (either direct or alternating) is passing through the plate.

6.8 An e.m.f is produced in a coil, which is not connected to an external voltage source. This can be due to

- (a) the coil being in a time varying magnetic field.
- (b) the coil moving in a time varying magnetic field.
- (c) the coil moving in a constant magnetic field.
- (d) the coil is stationary in external spatially varying magnetic field, which does not change with time.

6.9 The mutual inductance M_{12} of coil 1 with respect to coil 2

- (a) increases when they are brought nearer.
- (b) depends on the current passing through the coils.
- (c) increases when one of them is rotated about an axis.
- (d) is the same as M_{21} of coil 2 with respect to coil 1.

6.10 A circular coil expands radially in a region of magnetic field and no electromotive force is produced in the coil. This can be because

- (a) the magnetic field is constant.
- (b) the magnetic field is in the same plane as the circular coil and it may or may not vary.
- (c) the magnetic field has a perpendicular (to the plane of the coil) component whose magnitude is decreasing suitably.
- (d) there is a constant magnetic field in the perpendicular (to the plane of the coil) direction.

VSA

6.11 Consider a magnet surrounded by a wire with an on/off switch S (Fig 6.4). If the switch is thrown from the off position (open circuit) to the on position (closed circuit), will a current flow in the circuit? Explain.

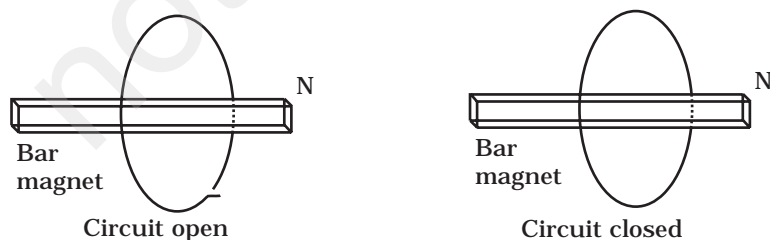

Fig. 6.4

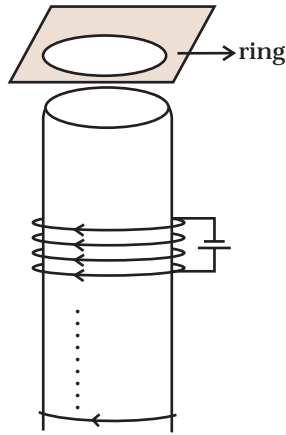

Fig. 6.5

6.12 A wire in the form of a tightly wound solenoid is connected to a DC source, and carries a current. If the coil is stretched so that there are gaps between successive elements of the spiral coil, will the current increase or decrease? Explain.

6.13 A solenoid is connected to a battery so that a steady current flows through it. If an iron core is inserted into the solenoid, will the current increase or decrease? Explain.

6.14 Consider a metal ring kept on top of a fixed solenoid (say on a cardboard) (Fig 6.5). The centre of the ring coincides with the axis of the solenoid. If the current is suddenly switched on, the metal ring jumps up. Explain

6.15 Consider a metal ring kept (supported by a cardboard) on top of a fixed solenoid carrying a current I (see Fig 6.5). The centre of the ring coincides with the axis of the solenoid. If the current in the solenoid is switched off, what will happen to the ring?

6.16 Consider a metallic pipe with an inner radius of 1 cm. If a cylindrical bar magnet of radius 0.8cm is dropped through the pipe, it takes more time to come down than it takes for a similar unmagnetised cylindrical iron bar dropped through the metallic pipe. Explain.

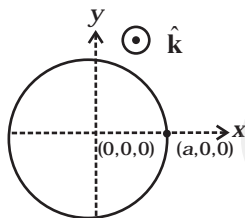

Fig. 6.6

SA

6.17 A magnetic field in a certain region is given by $\mathbf{B} = B_0 \cos(\omega t) \hat{\mathbf{k}}$ and a coil of radius a with resistance R is placed in the x - y plane with its centre at the origin in the magnetic field (see Fig 6.6) . Find the magnitude and the direction of the current at $(a, 0, 0)$ at $t = \pi/2\omega$, $t = \pi/\omega$ and $t = 3\pi/2\omega$.

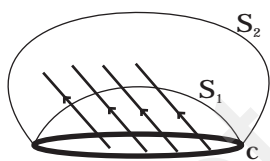

Fig. 6.7

6.18 Consider a closed loop C in a magnetic field (Fig 6.7). The flux passing through the loop is defined by choosing a surface whose edge coincides with the loop and using the formula $\phi = \mathbf{B}_1 \cdot d\mathbf{A}_1 + \mathbf{B}_2 \cdot d\mathbf{A}_2 + \dots$. Now if we chose two different surfaces S_1 and S_2 having C as their edge, would we get the same answer for flux. Justify your answer.

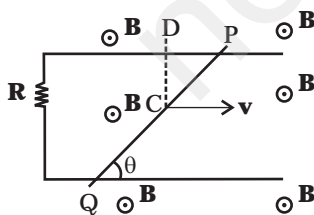

Fig. 6.8

6.19 Find the current in the wire for the configuration shown in Fig 6.8. Wire PQ has negligible resistance. \mathbf{B} , the magnetic field is coming out of the paper. θ is a fixed angle made by PQ travelling smoothly over two conducting parallel wires separated by a distance d .

- 6.20** A (current vs time) graph of the current passing through a solenoid is shown in Fig 6.9. For which time is the back electromotive force (\mathcal{E}) a maximum. If the back emf at $t = 3$ s is e , find the back emf at $t = 7$ s, 15 s and 40 s. OA, AB and BC are straight line segments.

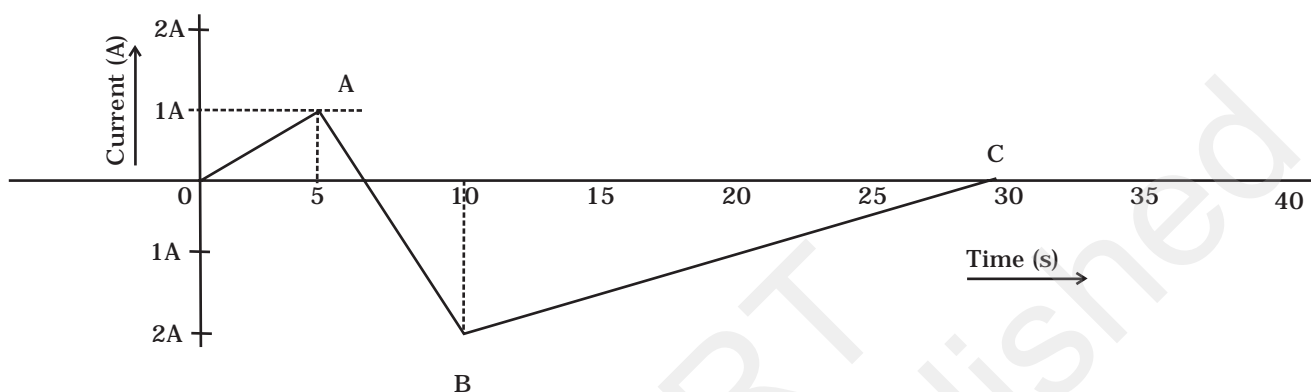

Fig. 6.9

- 6.21** There are two coils A and B separated by some distance. If a current of 2 A flows through A, a magnetic flux of 10^{-2} Wb passes through B (no current through B). If no current passes through A and a current of 1 A passes through B, what is the flux through A?

LA

- 6.22** A magnetic field $\mathbf{B} = B_0 \sin(\omega t) \hat{\mathbf{k}}$ covers a large region where a wire AB slides smoothly over two parallel conductors separated by a distance d (Fig. 6.10). The wires are in the x - y plane. The wire AB (of length d) has resistance R and the parallel wires have negligible resistance. If AB is moving with velocity \mathbf{v} , what is the current in the circuit. What is the force needed to keep the wire moving at constant velocity?

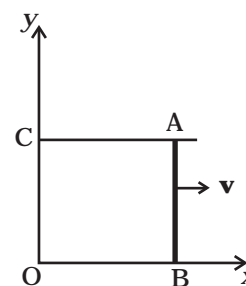

Fig. 6.10

- 6.23** A conducting wire XY of mass m and negligible resistance slides smoothly on two parallel conducting wires as shown in Fig 6.11. The closed circuit has a resistance R due to AC. AB and CD are perfect conductors. There is a magnetic field $\mathbf{B} = B(t)\hat{\mathbf{k}}$.

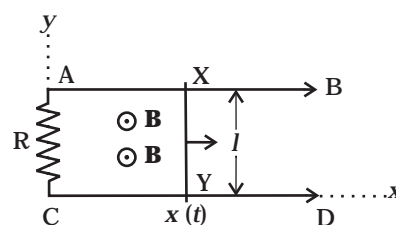

Fig. 6.11

- Write down equation for the acceleration of the wire XY.
- If \mathbf{B} is independent of time, obtain $v(t)$, assuming $v(0) = u_0$.
- For (b), show that the decrease in kinetic energy of XY equals the heat lost in R .

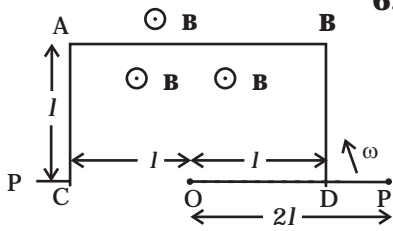

Fig. 6.12

6.24 ODBAC is a fixed rectangular conductor of negligible resistance (CO is not connected) and OP is a conductor which rotates clockwise with an angular velocity ω (Fig 6.12). The entire system is in a uniform magnetic field \mathbf{B} whose direction is along the normal to the surface of the rectangular conductor ABDC. The conductor OP is in electric contact with ABDC. The rotating conductor has a resistance of λ per unit length. Find the current in the rotating conductor, as it rotates by 180° .

6.25 Consider an infinitely long wire carrying a current $I(t)$, with $\frac{dI}{dt} = \lambda = \text{constant}$. Find the current produced in the rectangular loop of wire ABCD if its resistance is R (Fig. 6.13).

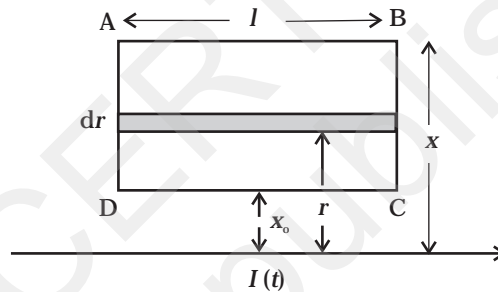

Fig. 6.13

6.26 A rectangular loop of wire ABCD is kept close to an infinitely long wire carrying a current $I(t) = I_0(1 - t/T)$ for $0 \leq t \leq T$ and $I(t) = 0$ for $t > T$ (Fig. 6.14). Find the total charge passing through a given point in the loop, in time T . The resistance of the loop is R .

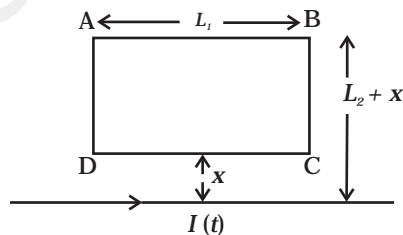

Fig. 6.14

Q.27 A magnetic field \mathbf{B} is confined to a region $r \leq a$ and points out of the paper (the z -axis), $r = 0$ being the centre of the circular region. A charged ring (charge = Q) of radius b , $b > a$ and mass m lies in the x - y plane with its centre at the origin. The ring is free to rotate and is at rest. The magnetic field is brought to zero in time Δt . Find the angular velocity ω of the ring after the field vanishes.

6.28 A rod of mass m and resistance R slides smoothly over two parallel perfectly conducting wires kept sloping at an angle θ with respect to the horizontal (Fig. 6.15). The circuit is closed through a perfect conductor at the top. There is a constant magnetic field \mathbf{B} along the vertical direction. If the rod is initially at rest, find the velocity of the rod as a function of time.

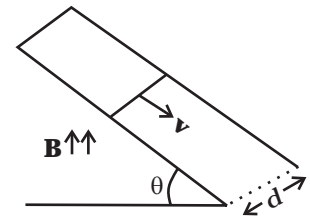

Fig. 6.15

6.29 Find the current in the sliding rod AB (resistance = R) for the arrangement shown in Fig 6.16. \mathbf{B} is constant and is out of the paper. Parallel wires have no resistance. \mathbf{v} is constant. Switch S is closed at time $t = 0$.

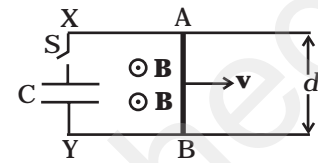

Fig. 6.16

6.30 Find the current in the sliding rod AB (resistance = R) for the arrangement shown in Fig 6.17. \mathbf{B} is constant and is out of the paper. Parallel wires have no resistance. \mathbf{v} is constant. Switch S is closed at time $t = 0$.

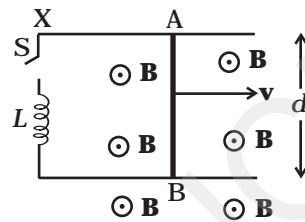

Fig. 6.17

6.31 A metallic ring of mass m and radius l (ring being horizontal) is falling under gravity in a region having a magnetic field. If z is the vertical direction, the z -component of magnetic field is $B_z = B_0(1 + \lambda z)$. If R is the resistance of the ring and if the ring falls with a velocity v , find the energy lost in the resistance. If the ring has reached a constant velocity, use the conservation of energy to determine v in terms of m , B , λ and acceleration due to gravity g .

6.32 A long solenoid 'S' has ' n ' turns per meter, with diameter ' a '. At the centre of this coil we place a smaller coil of ' N ' turns and diameter ' b ' (where $b < a$). If the current in the solenoid increases linearly, with time, what is the induced emf appearing in the smaller coil. Plot graph showing nature of variation in emf, if current varies as a function of $mt^2 + C$.

Chapter Seven

ALTERNATING CURRENT



MCQ 1

- 7.1** If the rms current in a 50 Hz ac circuit is 5 A, the value of the current $1/300$ seconds after its value becomes zero is
- (a) $5\sqrt{2}$ A
 - (b) $5\sqrt{3/2}$ A
 - (c) $5/6$ A
 - (d) $5/\sqrt{2}$ A
- 7.2** An alternating current generator has an internal resistance R_g and an internal reactance X_g . It is used to supply power to a passive load consisting of a resistance R_L and a reactance X_L . For maximum power to be delivered from the generator to the load, the value of X_L is equal to
- (a) zero.
 - (b) X_g .
 - (c) $-X_g$.
 - (d) R_g .

- 7.3** When a voltage measuring device is connected to AC mains, the meter shows the steady input voltage of 220V. This means
- input voltage cannot be AC voltage, but a DC voltage.
 - maximum input voltage is 220V.
 - the meter reads not v but $\langle v^2 \rangle$ and is calibrated to read $\sqrt{\langle v^2 \rangle}$.
 - the pointer of the meter is stuck by some mechanical defect.
- 7.4** To reduce the resonant frequency in an LCR series circuit with a generator
- the generator frequency should be reduced.
 - another capacitor should be added in parallel to the first.
 - the iron core of the inductor should be removed.
 - dielectric in the capacitor should be removed.
- 7.5** Which of the following combinations should be selected for better tuning of an LCR circuit used for communication?
- $R = 20 \Omega$, $L = 1.5 \text{ H}$, $C = 35 \mu\text{F}$.
 - $R = 25 \Omega$, $L = 2.5 \text{ H}$, $C = 45 \mu\text{F}$.
 - $R = 15 \Omega$, $L = 3.5 \text{ H}$, $C = 30 \mu\text{F}$.
 - $R = 25 \Omega$, $L = 1.5 \text{ H}$, $C = 45 \mu\text{F}$.
- 7.6** An inductor of reactance 1Ω and a resistor of 2Ω are connected in series to the terminals of a 6 V (rms) a.c. source. The power dissipated in the circuit is
- 8 W.
 - 12 W.
 - 14.4 W.
 - 18 W.
- 7.7** The output of a step-down transformer is measured to be 24 V when connected to a 12 watt light bulb. The value of the peak current is
- $1/\sqrt{2} \text{ A}$.
 - $\sqrt{2} \text{ A}$.
 - 2 A.
 - $2\sqrt{2} \text{ A}$.

MCQ II

- 7.8** As the frequency of an ac circuit increases, the current first increases and then decreases. What combination of circuit elements is most likely to comprise the circuit?
- Inductor and capacitor.
 - Resistor and inductor.
 - Resistor and capacitor.
 - Resistor, inductor and capacitor.
- 7.9** In an alternating current circuit consisting of elements in series, the current increases on increasing the frequency of supply. Which of the following elements are likely to constitute the circuit ?
- Only resistor.
 - Resistor and an inductor.
 - Resistor and a capacitor.
 - Only a capacitor.
- 7.10** Electrical energy is transmitted over large distances at high alternating voltages. Which of the following statements is (are) correct?
- For a given power level, there is a lower current.
 - Lower current implies less power loss.
 - Transmission lines can be made thinner.
 - It is easy to reduce the voltage at the receiving end using step-down transformers.
- 7.11** For an *LCR* circuit, the power transferred from the driving source to the driven oscillator is $P = I^2 Z \cos \phi$.
- Here, the power factor $\cos \phi \geq 0$, $P \geq 0$.
 - The driving force can give no energy to the oscillator ($P = 0$) in some cases.
 - The driving force cannot syphon out ($P < 0$) the energy out of oscillator.
 - The driving force can take away energy out of the oscillator.
- 7.12** When an AC voltage of 220 V is applied to the capacitor *C*
- the maximum voltage between plates is 220 V.
 - the current is in phase with the applied voltage.
 - the charge on the plates is in phase with the applied voltage.
 - power delivered to the capacitor is zero.

7.13 The line that draws power supply to your house from street has

- (a) zero average current.
- (b) 220 V average voltage.
- (c) voltage and current out of phase by 90° .
- (d) voltage and current possibly differing in phase ϕ such that

$$|\phi| < \frac{\pi}{2}.$$

VSA

7.14 If a LC circuit is considered analogous to a harmonically oscillating spring block system, which energy of the LC circuit would be analogous to potential energy and which one analogous to kinetic energy?

7.15 Draw the effective equivalent circuit of the circuit shown in Fig 7.1, at very high frequencies and find the effective impedance.

7.16 Study the circuits (a) and (b) shown in Fig 7.2 and answer the following questions.

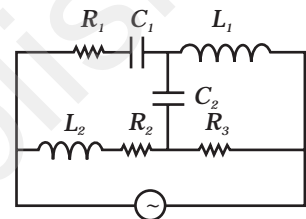
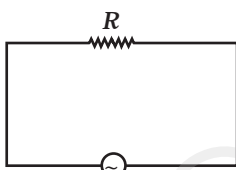
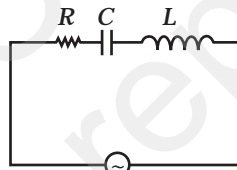

Fig. 7.1



(a)



(b)

Fig. 7.2

- (a) Under which conditions would the rms currents in the two circuits be the same?
- (b) Can the rms current in circuit (b) be larger than that in (a)?

7.17 Can the instantaneous power output of an ac source ever be negative? Can the average power output be negative?

7.18 In series LCR circuit, the plot of I_{\max} vs ω is shown in Fig 7.3. Find the bandwidth and mark in the figure.

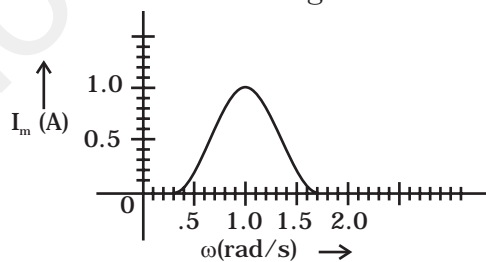

Fig. 7.3

- 7.19** The alternating current in a circuit is described by the graph shown in Fig 7.4 . Show rms current in this graph.

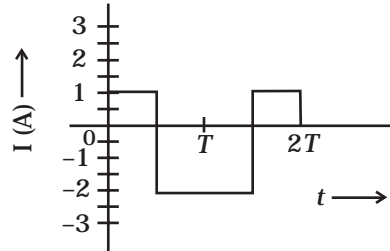

Fig. 7.4

- 7.20** How does the sign of the phase angle ϕ , by which the supply voltage leads the current in an *LCR* series circuit, change as the supply frequency is gradually increased from very low to very high values.

SA

- 7.21** A device 'X' is connected to an a.c source. The variation of voltage, current and power in one complete cycle is shown in Fig 7.5.
- Which curve shows power consumption over a full cycle?
 - What is the average power consumption over a cycle?
 - Identify the device 'X'.

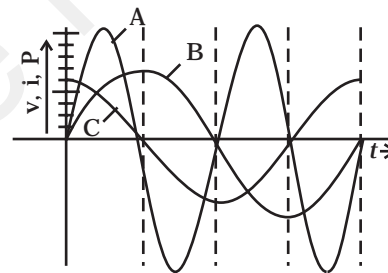

Fig. 7.5

- 7.22** Both alternating current and direct current are measured in amperes. But how is the ampere defined for an alternating current?
- 7.23** A coil of 0.01 henry inductance and 1 ohm resistance is connected to 200 volt, 50 Hz ac supply. Find the impedance of the circuit and time lag between max. alternating voltage and current.
- 7.24** A 60 W load is connected to the secondary of a transformer whose primary draws line voltage. If a current of 0.54 A flows in the

load, what is the current in the primary coil? Comment on the type of transformer being used.

- 7.25** Explain why the reactance provided by a capacitor to an alternating current decreases with increasing frequency.
- 7.26** Explain why the reactance offered by an inductor increases with increasing frequency of an alternating voltage.

LA

- 7.27** An electrical device draws 2kW power from AC mains (voltage 223V (rms) = $\sqrt{50,000}$ V). The current differs (lags) in phase by ϕ ($\tan \phi = \frac{-3}{4}$) as compared to voltage. Find (i) R , (ii) $X_C - X_L$, and (iii) I_M . Another device has twice the values for R , X_C and X_L . How are the answers affected?

- 7.28** 1MW power is to be delivered from a power station to a town 10 km away. One uses a pair of Cu wires of radius 0.5 cm for this purpose. Calculate the fraction of ohmic losses to power transmitted if
- (i) power is transmitted at 220V. Comment on the feasibility of doing this.
 - (ii) a step-up transformer is used to boost the voltage to 11000 V, power transmitted, then a step-down transformer is used to bring voltage to 220 V.
- ($\rho_{Cu} = 1.7 \times 10^{-8}$ SI unit)

- 7.29** Consider the LCR circuit shown in Fig 7.6. Find the net current i and the phase of i . Show that $i = \frac{v}{Z}$. Find the impedance Z for this circuit.

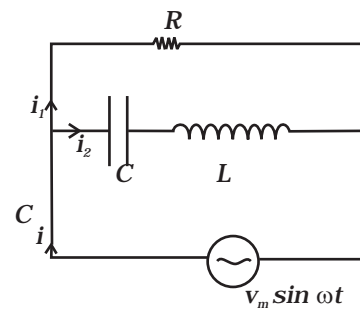

Fig. 7.6

- 7.30** For an LCR circuit driven at frequency ω , the equation reads

$$L \frac{di}{dt} + Ri + \frac{q}{C} = v_i = v_m \sin \omega t$$

- (i) Multiply the equation by i and simplify where possible.
- (ii) Interpret each term physically.

- (iii) Cast the equation in the form of a conservation of energy statement.
- (iv) Integrate the equation over one cycle to find that the phase difference between v and i must be acute.

7.31 In the LCR circuit shown in Fig 7.7, the ac driving voltage is $v = v_m \sin \omega t$.

- (i) Write down the equation of motion for $q(t)$.
- (ii) At $t = t_0$, the voltage source stops and R is short circuited. Now write down how much energy is stored in each of L and C .
- (iii) Describe subsequent motion of charges.

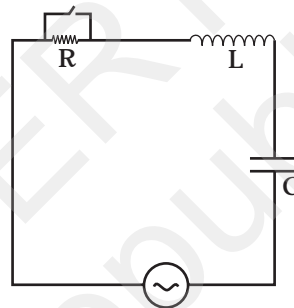

Fig. 7.7

Chapter Eight

ELECTROMAGNETIC WAVES



MCQ I

- 8.1** One requires 11eV of energy to dissociate a carbon monoxide molecule into carbon and oxygen atoms. The minimum frequency of the appropriate electromagnetic radiation to achieve the dissociation lies in
- (a) visible region.
 - (b) infrared region.
 - (c) ultraviolet region.
 - (d) microwave region.
- 8.2** A linearly polarized electromagnetic wave given as $\mathbf{E} = E_0 \hat{\mathbf{i}} \cos(\mathbf{kz} - \omega t)$ is incident normally on a perfectly reflecting infinite wall at $z = a$. Assuming that the material of the wall is optically inactive, the reflected wave will be given as
- (a) $\mathbf{E}_r = -E_0 \hat{\mathbf{i}} \cos(\mathbf{kz} - \omega t)$.
 - (b) $\mathbf{E}_r = E_0 \hat{\mathbf{i}} \cos(\mathbf{kz} + \omega t)$.

- (c) $\mathbf{E}_r = -E_0 \hat{\mathbf{i}} \cos(kz + \omega t)$.
- (d) $\mathbf{E}_r = E_0 \hat{\mathbf{i}} \sin(kz - \omega t)$.
- 8.3** Light with an energy flux of 20 W/cm^2 falls on a non-reflecting surface at normal incidence. If the surface has an area of 30 cm^2 , the total momentum delivered (for complete absorption) during 30 minutes is
- (a) $36 \times 10^{-5} \text{ kg m/s}$.
- (b) $36 \times 10^{-4} \text{ kg m/s}$.
- (c) $108 \times 10^4 \text{ kg m/s}$.
- (d) $1.08 \times 10^7 \text{ kg m/s}$.
- 8.4** The electric field intensity produced by the radiations coming from 100 W bulb at a 3 m distance is E . The electric field intensity produced by the radiations coming from 50 W bulb at the same distance is
- (a) $\frac{E}{2}$.
- (b) $2E$.
- (c) $\frac{E}{\sqrt{2}}$.
- (d) $\sqrt{2}E$.
- 8.5** If \mathbf{E} and \mathbf{B} represent electric and magnetic field vectors of the electromagnetic wave, the direction of propagation of electromagnetic wave is along
- (a) \mathbf{E} .
- (b) \mathbf{B} .
- (c) $\mathbf{B} \times \mathbf{E}$.
- (d) $\mathbf{E} \times \mathbf{B}$.
- 8.6** The ratio of contributions made by the electric field and magnetic field components to the intensity of an EM wave is
- (a) $c : 1$
- (b) $c^2 : 1$
- (c) $1 : 1$
- (d) $\sqrt{c} : 1$
- 8.7** An EM wave radiates outwards from a dipole antenna, with E_0 as the amplitude of its electric field vector. The electric field E_0 which

transports significant energy from the source falls off as

- (a) $\frac{1}{r^3}$
 (b) $\frac{1}{r^2}$
 (c) $\frac{1}{r}$
 (d) remains constant.

MCQ II

8.8 An electromagnetic wave travels in vacuum along z direction: $\mathbf{E} = (E_1\hat{\mathbf{i}} + E_2\hat{\mathbf{j}})\cos(kz - \omega t)$. Choose the correct options from the following:

(a) The associated magnetic field is given as

$$\mathbf{B} = \frac{1}{c}(E_1\hat{\mathbf{i}} - E_2\hat{\mathbf{j}})\cos(kz - \omega t).$$

(b) The associated magnetic field is given as

$$\mathbf{B} = \frac{1}{c}(E_1\hat{\mathbf{i}} + E_2\hat{\mathbf{j}})\cos(kz - \omega t).$$

- (c) The given electromagnetic field is circularly polarised.
 (d) The given electromagnetic wave is plane polarised.

8.9 An electromagnetic wave travelling along z-axis is given as: $\mathbf{E} = \mathbf{E}_0 \cos(kz - \omega t)$. Choose the correct options from the following:

(a) The associated magnetic field is given as $\mathbf{B} = \frac{1}{c}\hat{\mathbf{k}} \times \mathbf{E} = \frac{1}{\omega}(\hat{\mathbf{k}} \times \mathbf{E})$.

(b) The electromagnetic field can be written in terms of the associated magnetic field as $\mathbf{E} = c(\mathbf{B} \times \hat{\mathbf{k}})$.

(c) $\hat{\mathbf{k}} \cdot \mathbf{E} = 0, \hat{\mathbf{k}} \cdot \mathbf{B} = 0$.

(d) $\hat{\mathbf{k}} \times \mathbf{E} = 0, \hat{\mathbf{k}} \times \mathbf{B} = 0$.

8.10 A plane electromagnetic wave propagating along x direction can have the following pairs of \mathbf{E} and \mathbf{B}

- (a) E_x, B_y .
 (b) E_y, B_z .
 (c) B_x, E_y .
 (d) E_z, B_y .

- 8.11** A charged particle oscillates about its mean equilibrium position with a frequency of 10^9 Hz. The electromagnetic waves produced:
- will have frequency of 10^9 Hz.
 - will have frequency of 2×10^9 Hz.
 - will have a wavelength of 0.3 m.
 - fall in the region of radiowaves.
- 8.12** The source of electromagnetic waves can be a charge
- moving with a constant velocity.
 - moving in a circular orbit.
 - at rest.
 - falling in an electric field.
- 8.13** An EM wave of intensity I falls on a surface kept in vacuum and exerts radiation pressure p on it. Which of the following are true?
- Radiation pressure is I/c if the wave is totally absorbed.
 - Radiation pressure is I/c if the wave is totally reflected.
 - Radiation pressure is $2I/c$ if the wave is totally reflected.
 - Radiation pressure is in the range $I/c < p < 2I/c$ for real surfaces.

VSA

- 8.14** Why is the orientation of the portable radio with respect to broadcasting station important?
- 8.15** Why does microwave oven heats up a food item containing water molecules most efficiently?
- 8.16** The charge on a parallel plate capacitor varies as $q = q_0 \cos 2\pi vt$. The plates are very large and close together (area = A , separation = d). Neglecting the edge effects, find the displacement current through the capacitor?
- 8.17** A variable frequency a.c source is connected to a capacitor. How will the displacement current change with decrease in frequency?
- 8.18** The magnetic field of a beam emerging from a filter facing a floodlight is given by
 $B_0 = 12 \times 10^{-8} \sin (1.20 \times 10^7 z - 3.60 \times 10^{15} t)$ T.
 What is the average intensity of the beam?
- 8.19** Poynting vectors \mathbf{S} is defined as a vector whose magnitude is equal to the wave intensity and whose direction is along the direction of wave propagation. Mathematically, it is given by $\mathbf{S} = \frac{1}{\mu_0} \mathbf{E} \times \mathbf{B}$. Show the nature of S vs t graph.

- 8.20** Professor C.V Raman surprised his students by suspending freely a tiny light ball in a transparent vacuum chamber by shining a laser beam on it. Which property of EM waves was he exhibiting? Give one more example of this property.

SA

- 8.21** Show that the magnetic field B at a point in between the plates of a parallel-plate capacitor during charging is $\frac{\epsilon_0 \mu_r}{2} \frac{dE}{dt}$ (symbols having usual meaning).
- 8.22** Electromagnetic waves with wavelength
- λ_1 is used in satellite communication.
 - λ_2 is used to kill germs in water purifiers.
 - λ_3 is used to detect leakage of oil in underground pipelines.
 - λ_4 is used to improve visibility in runways during fog and mist conditions.
- Identify and name the part of electromagnetic spectrum to which these radiations belong.
 - Arrange these wavelengths in ascending order of their magnitude.
 - Write one more application of each.
- 8.23** Show that average value of radiant flux density 'S' over a single period 'T' is given by $S = \frac{1}{2c\mu_0} E_0^2$.
- 8.24** You are given a $2\mu\text{F}$ parallel plate capacitor. How would you establish an instantaneous displacement current of 1mA in the space between its plates?
- 8.25** Show that the radiation pressure exerted by an EM wave of intensity I on a surface kept in vacuum is I/c .
- 8.26** What happens to the intensity of light from a bulb if the distance from the bulb is doubled? As a laser beam travels across the length of a room, its intensity essentially remains constant.

What geometrical characteristic of LASER beam is responsible for the constant intensity which is missing in the case of light from the bulb?

- 8.27** Even though an electric field \mathbf{E} exerts a force $q\mathbf{E}$ on a charged particle yet the electric field of an EM wave does not contribute to the radiation pressure (but transfers energy). Explain.

LA

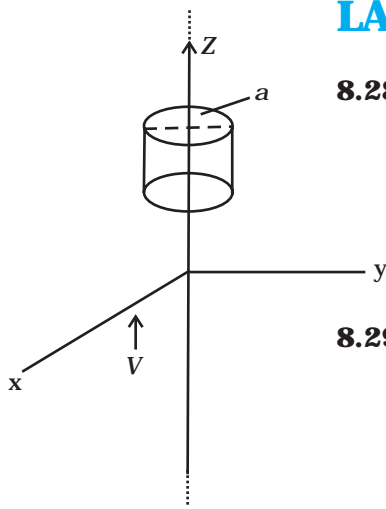

Fig. 8.1

- 8.28** An infinitely long thin wire carrying a uniform linear static charge density λ is placed along the z-axis (Fig. 8.1). The wire is set into motion along its length with a uniform velocity $\mathbf{v} = v\hat{\mathbf{k}}_z$. Calculate

the poynting vector $\mathbf{S} = \frac{1}{\mu_0}(\mathbf{E} \times \mathbf{B})$.

- 8.29** Sea water at frequency $\nu = 4 \times 10^8$ Hz has permittivity $\epsilon \approx 80 \epsilon_0$, permeability $\mu \approx \mu_0$ and resistivity $\rho = 0.25 \Omega\text{-m}$. Imagine a parallel plate capacitor immersed in sea water and driven by an alternating voltage source $V(t) = V_0 \sin(2\pi \nu t)$. What fraction of the conduction current density is the displacement current density?

- 8.30** A long straight cable of length l is placed symmetrically along z-axis and has radius $a (a \ll l)$. The cable consists of a thin wire and a co-axial conducting tube. An alternating current $I(t) = I_0 \sin(2\pi \nu t)$ flows down the central thin wire and returns along the co-axial conducting tube. The induced electric field at a distance s from the wire inside the cable is $\mathbf{E}(s, t) = \mu_0 I_0 \nu \cos(2\pi \nu t) \ln\left(\frac{s}{a}\right) \hat{\mathbf{k}}$.

- (i) Calculate the displacement current density inside the cable.
- (ii) Integrate the displacement current density across the cross-section of the cable to find the total displacement current I^d .
- (iii) Compare the conduction current I_0 with the displacement current I_0^d .

- 8.31** A plane EM wave travelling in vacuum along z direction is given by $\mathbf{E} = E_0 \sin(kz - \omega t)\hat{\mathbf{i}}$ and $\mathbf{B} = B_0 \sin(kz - \omega t)\hat{\mathbf{j}}$.

- (i) Evaluate $\oint \mathbf{E} \cdot d\mathbf{l}$ over the rectangular loop 1234 shown in Fig 8.2.
- (ii) Evaluate $\int \mathbf{B} \cdot d\mathbf{s}$ over the surface bounded by loop 1234.

(iii) Use equation $\oint \mathbf{E} \cdot d\mathbf{l} = \frac{-d\phi_B}{dt}$ to prove $\frac{E_0}{B_0} = c$.

(iv) By using similar process and the equation

$$\oint \mathbf{B} \cdot d\mathbf{l} = \mu_0 I + \varepsilon_0 \frac{d\phi_E}{dt}, \text{ prove that } c = \frac{1}{\sqrt{\mu_0 \varepsilon_0}}$$

8.32 A plane EM wave travelling along z direction is described by $\mathbf{E} = E_0 \sin(kz - \omega t)\hat{\mathbf{i}}$ and $\mathbf{B} = B_0 \sin(kz - \omega t)\hat{\mathbf{j}}$. Show that

(i) The average energy density of the wave is given by

$$u_{\text{av}} = \frac{1}{4} \varepsilon_0 E_0^2 + \frac{1}{4} \frac{B_0^2}{\mu_0}.$$

(ii) The time averaged intensity of the wave is given by

$$I_{\text{av}} = \frac{1}{2} c \varepsilon_0 E_0^2.$$

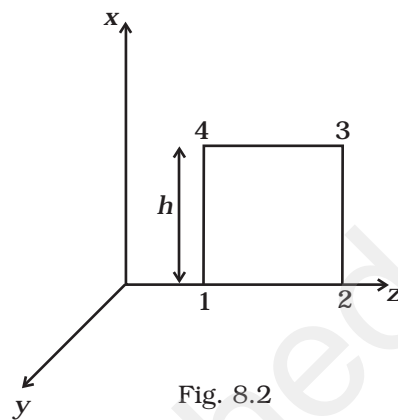

Fig. 8.2

Chapter Nine

RAY OPTICS AND OPTICAL INSTRUMENTS



MCQ I

- 9.1** A ray of light incident at an angle θ on a refracting face of a prism emerges from the other face normally. If the angle of the prism is 5° and the prism is made of a material of refractive index 1.5, the angle of incidence is
- (a) 7.5° .
 - (b) 5° .
 - (c) 15° .
 - (d) 2.5° .
- 9.2** A short pulse of white light is incident from air to a glass slab at normal incidence. After travelling through the slab, the first colour to emerge is
- (a) blue.
 - (b) green.
 - (c) violet.
 - (d) red.

- 9.3** An object approaches a convergent lens from the left of the lens with a uniform speed 5 m/s and stops at the focus. The image
- moves away from the lens with a uniform speed 5 m/s.
 - moves away from the lens with a uniform acceleration.
 - moves away from the lens with a non-uniform acceleration.
 - moves towards the lens with a non-uniform acceleration.
- 9.4** A passenger in an aeroplane shall
- never see a rainbow.
 - may see a primary and a secondary rainbow as concentric circles.
 - may see a primary and a secondary rainbow as concentric arcs.
 - shall never see a secondary rainbow.
- 9.5** You are given four sources of light each one providing a light of a single colour – red, blue, green and yellow. Suppose the angle of refraction for a beam of yellow light corresponding to a particular angle of incidence at the interface of two media is 90° . Which of the following statements is correct if the source of yellow light is replaced with that of other lights without changing the angle of incidence?
- The beam of red light would undergo total internal reflection.
 - The beam of red light would bend towards normal while it gets refracted through the second medium.
 - The beam of blue light would undergo total internal reflection.
 - The beam of green light would bend away from the normal as it gets refracted through the second medium.
- 9.6** The radius of curvature of the curved surface of a plano-convex lens is 20 cm. If the refractive index of the material of the lens be 1.5, it will
- act as a convex lens only for the objects that lie on its curved side.
 - act as a concave lens for the objects that lie on its curved side.
 - act as a convex lens irrespective of the side on which the object lies.
 - act as a concave lens irrespective of side on which the object lies.
- 9.7** The phenomena involved in the reflection of radiowaves by ionosphere is similar to
- reflection of light by a plane mirror.
 - total internal reflection of light in air during a mirage.
 - dispersion of light by water molecules during the formation of a rainbow.
 - scattering of light by the particles of air.

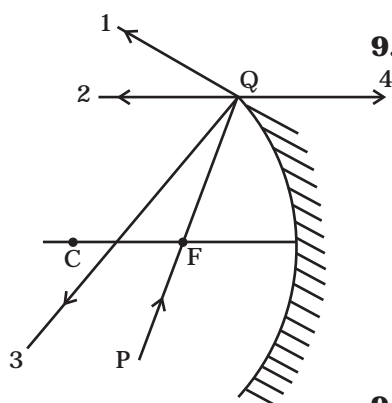

Fig. 9.1

9.8 The direction of ray of light incident on a concave mirror is shown by PQ while directions in which the ray would travel after reflection is shown by four rays marked 1, 2, 3 and 4 (Fig 9.1). Which of the four rays correctly shows the direction of reflected ray?

- (a) 1
- (b) 2
- (c) 3
- (d) 4

9.9 The optical density of turpentine is higher than that of water while its mass density is lower. Fig 9.2. shows a layer of turpentine floating over water in a container. For which one of the four rays incident on turpentine in Fig 9.2, the path shown is correct?

- (a) 1
- (b) 2
- (c) 3
- (d) 4

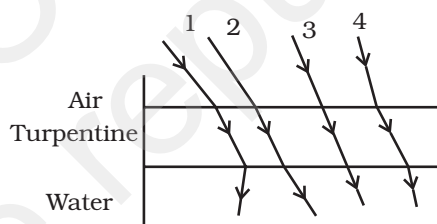

Fig. 9.2

9.10 A car is moving with at a constant speed of 60 km h^{-1} on a straight road. Looking at the rear view mirror, the driver finds that the car following him is at a distance of 100 m and is approaching with a speed of 5 km h^{-1} . In order to keep track of the car in the rear, the driver begins to glance alternatively at the rear and side mirror of his car after every 2 s till the other car overtakes. If the two cars were maintaining their speeds, which of the following statement (s) is/are correct?

- (a) The speed of the car in the rear is 65 km h^{-1} .
- (b) In the side mirror the car in the rear would appear to approach with a speed of 5 km h^{-1} to the driver of the leading car.
- (c) In the rear view mirror the speed of the approaching car would appear to decrease as the distance between the cars decreases.
- (d) In the side mirror, the speed of the approaching car would appear to increase as the distance between the cars decreases.

- 9.11** There are certain material developed in laboratories which have a negative refractive index (Fig. 9.3). A ray incident from air (medium 1) into such a medium (medium 2) shall follow a path given by

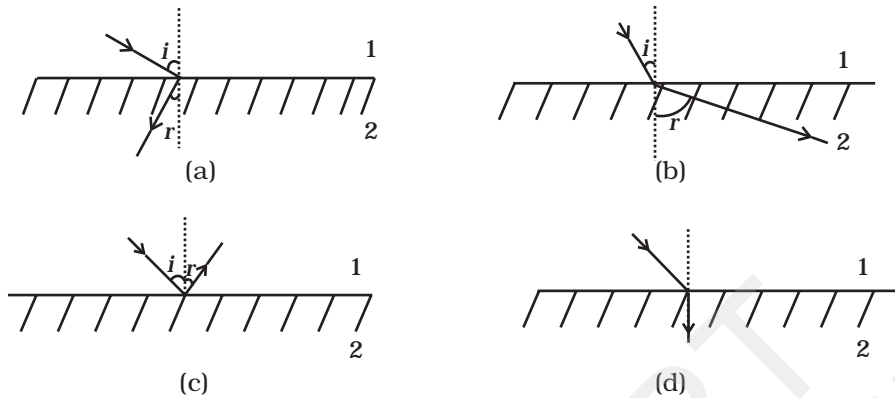

Fig. 9.3

MCQ II

- 9.12** Consider an extended object immersed in water contained in a plane trough. When seen from close to the edge of the trough the object looks distorted because
- the apparent depth of the points close to the edge are nearer the surface of the water compared to the points away from the edge.
 - the angle subtended by the image of the object at the eye is smaller than the actual angle subtended by the object in air.
 - some of the points of the object far away from the edge may not be visible because of total internal reflection.
 - water in a trough acts as a lens and magnifies the object.
- 9.13** A rectangular block of glass ABCD has a refractive index 1.6. A pin is placed midway on the face AB (Fig. 9.4). When observed from the face AD, the pin shall
- appear to be near A.
 - appear to be near D.
 - appear to be at the centre of AD.
 - not be seen at all.
- 9.14** Between the primary and secondary rainbows, there is a dark band known as Alexander's dark band. This is because
- light scattered into this region interfere destructively.
 - there is no light scattered into this region.

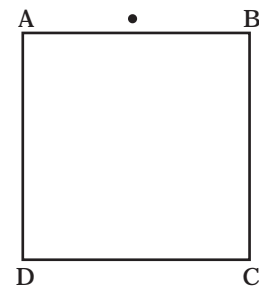

Fig. 9.4

- (c) light is absorbed in this region.
 (d) angle made at the eye by the scattered rays with respect to the incident light of the sun lies between approximately 42° and 50° .
- 9.15** A magnifying glass is used, as the object to be viewed can be brought closer to the eye than the normal near point. This results in
- (a) a larger angle to be subtended by the object at the eye and hence viewed in greater detail.
 (b) the formation of a virtual erect image.
 (c) increase in the field of view.
 (d) infinite magnification at the near point.
- 9.16** An astronomical refractive telescope has an objective of focal length 20m and an eyepiece of focal length 2cm.
- (a) The length of the telescope tube is 20.02m.
 (b) The magnification is 1000.
 (c) The image formed is inverted.
 (d) An objective of a larger aperture will increase the brightness and reduce chromatic aberration of the image.

VSA

- 9.17** Will the focal length of a lens for red light be more, same or less than that for blue light?
- 9.18** The near vision of an average person is 25cm. To view an object with an angular magnification of 10, what should be the power of the microscope?
- 9.19** An unsymmetrical double convex thin lens forms the image of a point object on its axis. Will the position of the image change if the lens is reversed?
- 9.20** Three immiscible liquids of densities $d_1 > d_2 > d_3$ and refractive indices $\mu_1 > \mu_2 > \mu_3$ are put in a beaker. The height of each liquid column is $\frac{h}{3}$. A dot is made at the bottom of the beaker. For near normal vision, find the apparent depth of the dot.
- 9.21** For a glass prism ($\mu = \sqrt{3}$) the angle of minimum deviation is equal to the angle of the prism. Find the angle of the prism.

SA

- 9.22** A short object of length L is placed along the principal axis of a concave mirror away from focus. The object distance is u . If the mirror has a focal length f , what will be the length of the image? You may take $L \ll |v - f|$.
- 9.23** A circular disc of radius ' R ' is placed co-axially and horizontally inside an opaque hemispherical bowl of radius ' a ' (Fig. 9.5). The far edge of the disc is just visible when viewed from the edge of the bowl. The bowl is filled with transparent liquid of refractive index μ and the near edge of the disc becomes just visible. How far below the top of the bowl is the disc placed?
- 9.24** A thin convex lens of focal length 25 cm is cut into two pieces 0.5 cm above the principal axis. The top part is placed at (0,0) and an object placed at (-50 cm, 0). Find the coordinates of the image.
- 9.25** In many experimental set-ups the source and screen are fixed at a distance say D and the lens is movable. Show that there are two positions for the lens for which an image is formed on the screen. Find the distance between these two points and the ratio of the image sizes for these two points.
- 9.26** A jar of height h is filled with a transparent liquid of refractive index μ (Fig. 9.6). At the centre of the jar on the bottom surface is a dot. Find the minimum diameter of a disc, such that when placed on the top surface symmetrically about the centre, the dot is invisible.

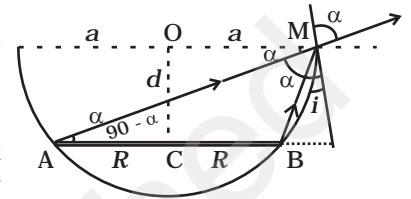

Fig. 9.5

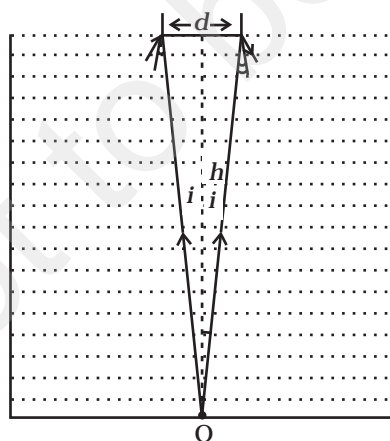

Fig. 9.6

- 9.27** A myopic adult has a far point at 0.1 m. His power of accommodation is 4 diopters. (i) What power lenses are required to see distant

objects? (ii) What is his near point without glasses? (iii) What is his near point with glasses? (Take the image distance from the lens of the eye to the retina to be 2 cm.)

LA

9.28 Show that for a material with refractive index $\mu \geq \sqrt{2}$, light incident at any angle shall be guided along a length perpendicular to the incident face.

9.29 The mixture a pure liquid and a solution in a long vertical column (i.e. horizontal dimensions \ll vertical dimensions) produces diffusion of solute particles and hence a refractive index gradient along the vertical dimension. A ray of light entering the column at right angles to the vertical is deviated from its original path. Find the deviation in travelling a horizontal distance $d \ll h$, the height of the column.

9.30 If light passes near a massive object, the gravitational interaction causes a bending of the ray. This can be thought of as happening due to a change in the effective refractive index of the medium given by

$$n(r) = 1 + 2 GM/rc^2$$

where r is the distance of the point of consideration from the centre of the mass of the massive body, G is the universal gravitational constant, M the mass of the body and c the speed of light in vacuum. Considering a spherical object find the deviation of the ray from the original path as it grazes the object.

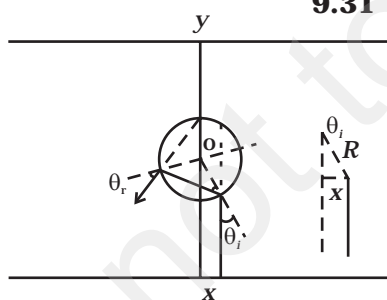

Fig. 9.7

9.31 An infinitely long cylinder of radius R is made of an unusual exotic material with refractive index -1 (Fig. 9.7). The cylinder is placed between two planes whose normals are along the y direction. The center of the cylinder O lies along the y -axis. A narrow laser beam is directed along the y direction from the lower plate. The laser source is at a horizontal distance x from the diameter in the y direction. Find the range of x such that light emitted from the lower plane does not reach the upper plane.

9.32 (i) Consider a thin lens placed between a source (S) and an observer (O) (Fig. 9.8). Let the thickness of the lens vary as

$$w(b) = w_0 - \frac{b^2}{\alpha}, \text{ where } b \text{ is the vertical distance from the pole.}$$

w_0 is a constant. Using Fermat's principle i.e. the time of transit

for a ray between the source and observer is an extremum, find the condition that all paraxial rays starting from the source will converge at a point O on the axis. Find the focal length.

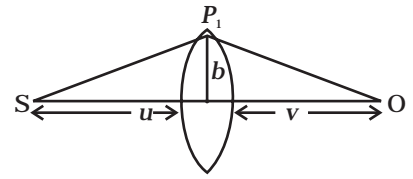

Fig. 9.8

- (ii) A gravitational lens may be assumed to have a varying width of the form

$$w(b) = k_1 \ln \left(\frac{k_2}{b} \right) \quad b_{\min} < b < b_{\max}$$

$$= k_1 \ln \left(\frac{k_2}{b_{\min}} \right) \quad b < b_{\min}$$

Show that an observer will see an image of a point object as a ring about the center of the lens with an angular radius

$$\beta = \sqrt{\frac{(n-1)k_1 \frac{u}{v}}{u+v}}.$$

Chapter Ten

WAVE OPTICS



MCQ I

10.1 Consider a light beam incident from air to a glass slab at Brewster's angle as shown in Fig. 10.1.

A polaroid is placed in the path of the emergent ray at point P and rotated about an axis passing through the centre and perpendicular to the plane of the polaroid.

- (a) For a particular orientation there shall be darkness as observed through the polaroid.
- (b) The intensity of light as seen through the polaroid shall be independent of the rotation.
- (c) The intensity of light as seen through the Polaroid shall go through a minimum but not zero for two orientations of the polaroid.
- (d) The intensity of light as seen through the polaroid shall go through a minimum for four orientations of the polaroid.

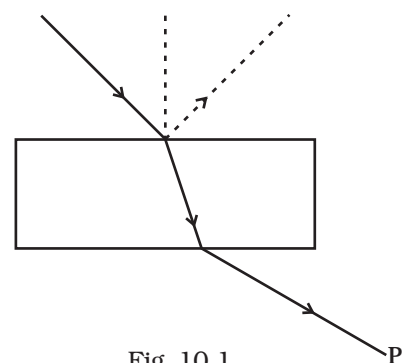

Fig. 10.1

10.2 Consider sunlight incident on a slit of width 10^4 \AA . The image seen through the slit shall

- (a) be a fine sharp slit white in colour at the center.
- (b) a bright slit white at the center diffusing to zero intensities at the edges.
- (c) a bright slit white at the center diffusing to regions of different colours.
- (d) only be a diffused slit white in colour.

10.3 Consider a ray of light incident from air onto a slab of glass (refractive index n) of width d , at an angle θ . The phase difference between the ray reflected by the top surface of the glass and the bottom surface is

- (a) $\frac{4\pi d}{\lambda} \left(1 - \frac{1}{n^2} \sin^2 \theta\right)^{1/2} + \pi$
- (b) $\frac{4\pi d}{\lambda} \left(1 - \frac{1}{n^2} \sin^2 \theta\right)^{1/2}$
- (c) $\frac{4\pi d}{\lambda} \left(1 - \frac{1}{n^2} \sin^2 \theta\right)^{1/2} + \frac{\pi}{2}$
- (d) $\frac{4\pi d}{\lambda} \left(1 - \frac{1}{n^2} \sin^2 \theta\right)^{1/2} + 2\pi$.

10.4 In a Young's double slit experiment, the source is white light. One of the holes is covered by a red filter and another by a blue filter. In this case

- (a) there shall be alternate interference patterns of red and blue.
- (b) there shall be an interference pattern for red distinct from that for blue.
- (c) there shall be no interference fringes.
- (d) there shall be an interference pattern for red mixing with one for blue.

10.5 Figure 10.2 shows a standard two slit arrangement with slits S_1, S_2 . P_1, P_2 are the two minima points on either side of P (Fig. 10.2).

At P_2 on the screen, there is a hole and behind P_2 is a second 2-slit arrangement with slits S_3, S_4 and a second screen behind them.

- (a) There would be no interference pattern on the second screen but it would be lighted.
- (b) The second screen would be totally dark.

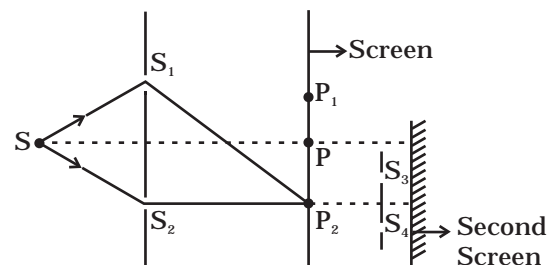

Fig. 10.2

- (c) There would be a single bright point on the second screen.
 (d) There would be a regular two slit pattern on the second screen.

MCQ II

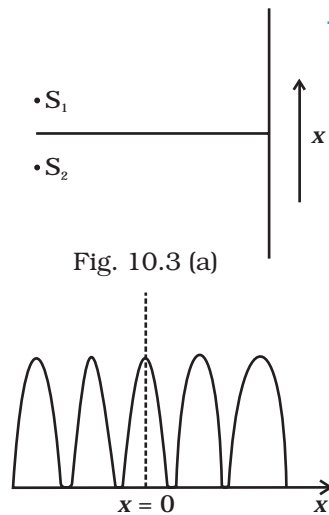

Fig. 10.3 (a)

Fig. 10.3 (b)

10.6 Two sources S_1 and S_2 of intensities I_1 and I_2 are placed in front of a screen [Fig. 10.3 (a)]. The pattern of intensity distribution seen in the central portion is given by Fig. 10.3 (b).

In this case which of the following statements are true.

- (a) S_1 and S_2 have the same intensities.
 (b) S_1 and S_2 have a constant phase difference.
 (c) S_1 and S_2 have the same phase.
 (d) S_1 and S_2 have the same wavelength.
- 10.7** Consider sunlight incident on a pinhole of width 10^3 \AA . The image of the pinhole seen on a screen shall be
- (a) a sharp white ring.
 (b) different from a geometrical image.
 (c) a diffused central spot, white in colour.
 (d) diffused coloured region around a sharp central white spot.
- 10.8** Consider the diffraction pattern for a small pinhole. As the size of the hole is increased
- (a) the size decreases.
 (b) the intensity increases.
 (c) the size increases.
 (d) the intensity decreases.
- 10.9** For light diverging from a point source
- (a) the wavefront is spherical.
 (b) the intensity decreases in proportion to the distance squared.
 (c) the wavefront is parabolic.
 (d) the intensity at the wavefront does not depend on the distance.

VSA

- 10.10** Is Huygen's principle valid for longitudinal sound waves?
- 10.11** Consider a point at the focal point of a convergent lens. Another convergent lens of short focal length is placed on the other side. What is the nature of the wavefronts emerging from the final image?
- 10.12** What is the shape of the wavefront on earth for sunlight?

- 10.13** Why is the diffraction of sound waves more evident in daily experience than that of light wave?
- 10.14** The human eye has an approximate angular resolution of $\phi = 5.8 \times 10^{-4}$ rad and a typical photocopier prints a minimum of 300 dpi (dots per inch, 1 inch = 2.54 cm). At what minimal distance z should a printed page be held so that one does not see the individual dots.
- 10.15** A polaroid (I) is placed in front of a monochromatic source. Another polaroid (II) is placed in front of this polaroid (I) and rotated till no light passes. A third polaroid (III) is now placed in between (I) and (II). In this case, will light emerge from (II). Explain.

SA

- 10.16** Can reflection result in plane polarised light if the light is incident on the interface from the side with higher refractive index?
- 10.17** For the same objective, find the ratio of the least separation between two points to be distinguished by a microscope for light of 5000 \AA and electrons accelerated through 100V used as the illuminating substance.
- 10.18** Consider a two slit interference arrangements (Fig. 10.4) such that the distance of the screen from the slits is half the distance between the slits. Obtain the value of D in terms of λ such that the first minima on the screen falls at a distance D from the centre O .

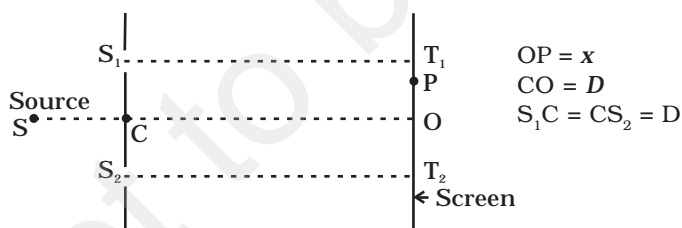

Fig. 10.4

LA

- 10.19** Figure 10.5 shown a two slit arrangement with a source which emits unpolarised light. P is a polariser with axis whose direction is not given. If I_0 is the intensity of the principal maxima when *no* polariser is present, calculate in the present case, the intensity of the principal maxima as well as of the first minima.

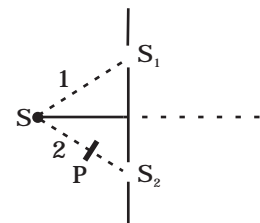

Fig. 10.5

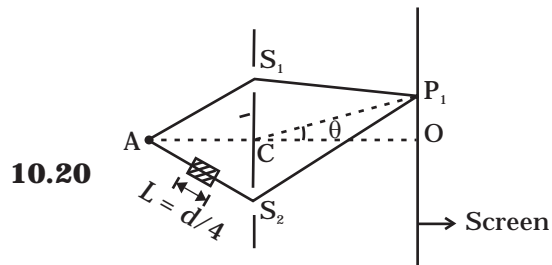

Fig. 10.6

$$AC = CO = D, S_1C = S_2C = d \ll D$$

A small transparent slab containing material of $\mu = 1.5$ is placed along AS_2 (Fig.10.6). What will be the distance from O of the principal maxima and of the first minima on either side of the principal maxima obtained in the absence of the glass slab. .

10.21 Four identical monochromatic sources A,B,C,D as shown in the (Fig.10.7) produce waves of the same wavelength λ and are coherent. Two receiver R_1 and R_2 are at great but equal distances from B.

- (i) Which of the two receivers picks up the larger signal?
- (ii) Which of the two receivers picks up the larger signal when B is turned off?
- (iii) Which of the two receivers picks up the larger signal when D is turned off?
- (iv) Which of the two receivers can distinguish which of the sources B or D has been turned off?

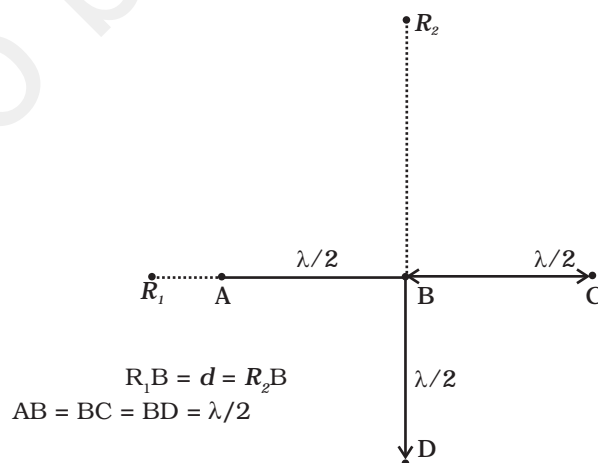

Fig. 10.7

10.22 The optical properties of a medium are governed by the relative permittivity (ϵ_r) and relative permeability (μ_r). The refractive index is defined as $\sqrt{\mu_r \epsilon_r} = n$. For ordinary material $\epsilon_r > 0$ and $\mu_r > 0$ and the positive sign is taken for the square root. In 1964, a Russian scientist V. Veselago postulated the existence of material with $\epsilon_r < 0$ and $\mu_r < 0$. Since then such 'metamaterials' have been produced in the laboratories and their optical properties studied. For such materials $n = -\sqrt{\mu_r \epsilon_r}$. As light enters a medium of such refractive index the phases travel away from the direction of propagation.

- (i) According to the description above show that if rays of light enter such a medium from air (refractive index = 1) at an angle θ in 2nd quadrant, then the refracted beam is in the 3rd quadrant.
- (ii) Prove that Snell's law holds for such a medium.

10.23 To ensure almost 100 per cent transmittivity, photographic lenses are often coated with a thin layer of dielectric material. The refractive index of this material is intermediated between that of air and glass (which makes the optical element of the lens). A typically used dielectric film is MgF_2 ($n = 1.38$). What should the thickness of the film be so that at the center of the visible spectrum (5500 \AA) there is maximum transmission.

Chapter Eleven

DUAL NATURE OF RADIATION AND MATTER



MCQ I

- 11.1** A particle is dropped from a height H . The de Broglie wavelength of the particle as a function of height is proportional to
- (a) H
 - (b) $H^{1/2}$
 - (c) H^p
 - (b) $H^{-1/2}$
- 11.2** The wavelength of a photon needed to remove a proton from a nucleus which is bound to the nucleus with 1 MeV energy is nearly
- (a) 1.2 nm
 - (b) 1.2×10^{-3} nm
 - (c) 1.2×10^{-6} nm
 - (d) 1.2×10^1 nm
- 11.3** Consider a beam of electrons (each electron with energy E_0) incident on a metal surface kept in an evacuated chamber. Then

- (a) no electrons will be emitted as only photons can emit electrons.
- (b) electrons can be emitted but all with an energy, E_0 .
- (c) electrons can be emitted with any energy, with a maximum of $E_0 - \phi$ (ϕ is the work function).
- (d) electrons can be emitted with any energy, with a maximum of E_0 .

11.4 Consider Fig. 11.7 in the NCERT text book of physics for Class XII. Suppose the voltage applied to A is increased. The diffracted beam will have the maximum at a value of θ that

- (a) will be larger than the earlier value.
- (b) will be the same as the earlier value.
- (c) will be less than the earlier value.
- (d) will depend on the target.

11.5 A proton, a neutron, an electron and an α -particle have same energy. Then their de Broglie wavelengths compare as

- (a) $\lambda_p = \lambda_n > \lambda_e > \lambda_\alpha$
- (b) $\lambda_\alpha < \lambda_p = \lambda_n > \lambda_e$
- (c) $\lambda_e < \lambda_p = \lambda_n > \lambda_\alpha$
- (d) $\lambda_e = \lambda_p = \lambda_n = \lambda_\alpha$

11.6 An electron is moving with an initial velocity $\mathbf{v} = v_0 \hat{\mathbf{i}}$ and is in a magnetic field $\mathbf{B} = B_0 \hat{\mathbf{j}}$. Then it's de Broglie wavelength

- (a) remains constant.
- (b) increases with time.
- (c) decreases with time.
- (d) increases and decreases periodically.

11.7 An electron (mass m) with an initial velocity $\mathbf{v} = v_0 \hat{\mathbf{i}}$ ($v_0 > 0$) is in an electric field $\mathbf{E} = -E_0 \hat{\mathbf{i}}$ ($E_0 = \text{constant} > 0$). It's de Broglie wavelength at time t is given by

(a)
$$\frac{\lambda_0}{\left(1 + \frac{eE_0 t}{m v_0}\right)}$$

(b)
$$\lambda_0 \left(1 + \frac{eE_0 t}{m v_0}\right)$$

- (c) λ_0
- (d) $\lambda_0 t$.

11.8 An electron (mass m) with an initial velocity $\mathbf{v} = v_0 \hat{\mathbf{i}}$ is in an electric field $\mathbf{E} = E_0 \hat{\mathbf{j}}$. If $\lambda_0 = h/mv_0$, its de Broglie wavelength at time t is given by

(a) λ_0

(b) $\lambda_0 \sqrt{1 + \frac{e^2 E_0^2 t^2}{m^2 v_0^2}}$

(c) $\frac{\lambda_0}{\sqrt{1 + \frac{e^2 E_0^2 t^2}{m^2 v_0^2}}}$

(d) $\frac{\lambda_0}{\left(1 + \frac{e^2 E_0^2 t^2}{m^2 v_0^2}\right)}$

MCQ II

11.9 Relativistic corrections become necessary when the expression for the kinetic energy $\frac{1}{2}mv^2$, becomes comparable with mc^2 , where m is the mass of the particle. At what de Broglie wavelength will relativistic corrections become important for an electron?

(a) $\lambda = 10\text{nm}$

(b) $\lambda = 10^{-1}\text{nm}$

(c) $\lambda = 10^{-4}\text{nm}$

(d) $\lambda = 10^{-6}\text{nm}$

11.10 Two particles A_1 and A_2 of masses m_1, m_2 ($m_1 > m_2$) have the same de Broglie wavelength. Then

(a) their momenta are the same.

(b) their energies are the same.

(c) energy of A_1 is less than the energy of A_2 .

(d) energy of A_1 is more than the energy of A_2 .

11.11 The de Broglie wavelength of a photon is twice the de Broglie wavelength of an electron. The speed of the electron is $v_e = \frac{c}{100}$. Then

(a) $\frac{E_e}{E_p} = 10^{-4}$

(b) $\frac{E_e}{E_p} = 10^{-2}$

(c) $\frac{P_e}{m_e c} = 10^{-2}$

(d) $\frac{P_e}{m_e c} = 10^{-4}$

11.12 Photons absorbed in matter are converted to heat. A source emitting n photon/sec of frequency ν is used to convert 1kg of ice at 0°C to water at 0°C . Then, the time T taken for the conversion

- (a) decreases with increasing n , with ν fixed.
- (b) decreases with n fixed, ν increasing
- (c) remains constant with n and ν changing such that $n\nu = \text{constant}$.
- (d) increases when the product $n\nu$ increases.

11.13 A particle moves in a closed orbit around the origin, due to a force which is directed towards the origin. The de Broglie wavelength of the particle varies cyclically between two values λ_1 , λ_2 with $\lambda_1 > \lambda_2$. Which of the following statement are true?

- (a) The particle could be moving in a circular orbit with origin as centre
- (b) The particle could be moving in an elliptic orbit with origin as its focus.
- (c) When the de Broglie wave length is λ_1 , the particle is nearer the origin than when its value is λ_2 .
- (d) When the de Broglie wavelength is λ_2 , the particle is nearer the origin than when its value is λ_1 .

VSA

11.14 A proton and an α -particle are accelerated, using the same potential difference. How are the deBroglie wavelengths λ_p and λ_α related to each other?

11.15 (i) In the explanation of photo electric effect, we assume one photon of frequency ν collides with an electron and transfers

its energy. This leads to the equation for the maximum energy E_{max} of the emitted electron as

$$E_{max} = h\nu - \phi_0$$

where ϕ_0 is the work function of the metal. If an electron absorbs 2 photons (each of frequency ν) what will be the maximum energy for the emitted electron?

(ii) Why is this fact (two photon absorption) not taken into consideration in our discussion of the stopping potential?

11.16 There are materials which absorb photons of shorter wavelength and emit photons of longer wavelength. Can there be stable substances which absorb photons of larger wavelength and emit light of shorter wavelength.

11.17 Do all the electrons that absorb a photon come out as photoelectrons?

11.18 There are two sources of light, each emitting with a power of 100 W. One emits X-rays of wavelength 1nm and the other visible light at 500 nm. Find the ratio of number of photons of X-rays to the photons of visible light of the given wavelength?

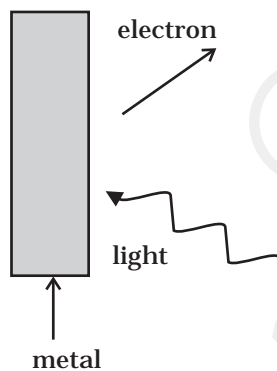

Fig. 11.1

SA
11.19 Consider Fig. 11.1 for photoemission.

How would you reconcile with momentum-conservation? Note light (photons) have momentum in a different direction than the emitted electrons.

11.20 Consider a metal exposed to light of wavelength 600 nm. The maximum energy of the electron doubles when light of wavelength 400 nm is used. Find the work function in eV.

11.21 Assuming an electron is confined to a 1nm wide region, find the uncertainty in momentum using Heisenberg Uncertainty principle (Ref Eq 11.12 of NCERT Textbook). You can assume the uncertainty in position Δx as 1nm. Assuming $p \approx \Delta p$, find the energy of the electron in electron volts.

11.22 Two monochromatic beams A and B of equal intensity I , hit a screen. The number of photons hitting the screen by beam A is

twice that by beam B. Then what inference can you make about their frequencies?

- 11.23** Two particles A and B of de Broglie wavelengths λ_1 and λ_2 combine to form a particle C. The process conserves momentum. Find the de Broglie wavelength of the particle C. (The motion is one dimensional).
- 11.24** A neutron beam of energy E scatters from atoms on a surface with a spacing $d = 0.1 \text{ nm}$. The first maximum of intensity in the reflected beam occurs at $\theta = 30^\circ$. What is the kinetic energy E of the beam in eV?

LA

- 11.25** Consider a thin target (10^{-2} m square, 10^{-3} m thickness) of sodium, which produces a photocurrent of $100 \mu\text{A}$ when a light of intensity 100 W/m^2 ($\lambda = 660 \text{ nm}$) falls on it. Find the probability that a photoelectron is produced when a photons strikes a sodium atom. [Take density of Na = 0.97 kg/m^3].
- 11.26** Consider an electron in front of metallic surface at a distance d (treated as an infinite plane surface). Assume the force of attraction

by the plate is given as $\frac{1}{4} \frac{q^2}{4\pi\epsilon_0 d^2}$

Calculate work in taking the charge to an infinite distance from the plate. Taking $d = 0.1 \text{ nm}$, find the work done in electron volts. [Such a force law is not valid for $d < 0.1 \text{ nm}$].

- 11.27** A student performs an experiment on photoelectric effect, using two materials A and B. A plot of V_{stop} vs ν is given in Fig. 11.2.
- (i) Which material A or B has a higher work function?
- (ii) Given the electric charge of an electron = $1.6 \times 10^{-19} \text{ C}$, find the value of h obtained from the experiment for both A and B.

Comment on whether it is consistent with Einstein's theory:

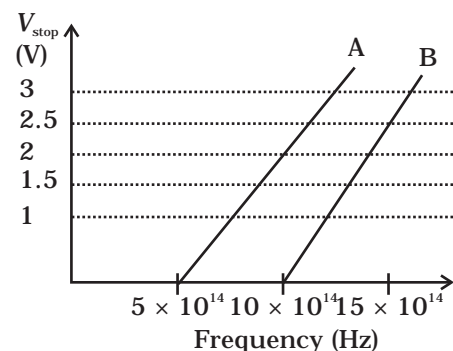

Fig. 11.2

- 11.28** A particle A with a mass m_A is moving with a velocity v and hits a particle B (mass m_B) at rest (one dimensional motion). Find the

change in the de Broglie wavelength of the particle A. Treat the collision as elastic.

11.29 Consider a 20 W bulb emitting light of wavelength 5000 \AA and shining on a metal surface kept at a distance 2m. Assume that the metal surface has work function of 2 eV and that each atom on the metal surface can be treated as a circular disk of radius 1.5 \AA .

- (i) Estimate no. of photons emitted by the bulb per second. [Assume no other losses]
- (ii) Will there be photoelectric emission?
- (iii) How much time would be required by the atomic disk to receive energy equal to work function (2 eV)?
- (iv) How many photons would atomic disk receive within time duration calculated in (iii) above?
- (v) Can you explain how photoelectric effect was observed instantaneously?

[Hint: Time calculated in part (iii) is from classical consideration and you may further take the target of surface area say 1cm^2 and estimate what would happen?]

Chapter Twelve

ATOMS



MCQ I

12.1 Taking the Bohr radius as $a_0 = 53\text{pm}$, the radius of Li^{++} ion in its ground state, on the basis of Bohr's model, will be about

- (a) 53 pm
- (b) 27 pm
- (c) 18 pm
- (d) 13 pm

12.2 The binding energy of a H-atom, considering an electron moving around a fixed nuclei (proton), is $B = -\frac{me^4}{8n^2\epsilon_0^2h^2}$. (m = electron mass).

If one decides to work in a frame of reference where the electron is at rest, the proton would be moving around it. By similar arguments, the binding energy would be

$$B = -\frac{Me^4}{8n^2\epsilon_0^2h^2} \quad (M = \text{proton mass})$$

- This last expression is not correct because
- n would not be integral.
 - Bohr-quantisation applies only to electron
 - the frame in which the electron is at rest is not inertial.
 - the motion of the proton would not be in circular orbits, even approximately.
- 12.3** The simple Bohr model cannot be directly applied to calculate the energy levels of an atom with many electrons. This is because
- of the electrons not being subject to a central force.
 - of the electrons colliding with each other
 - of screening effects
 - the force between the nucleus and an electron will no longer be given by Coulomb's law.
- 12.4** For the ground state, the electron in the H-atom has an angular momentum = h , according to the simple Bohr model. Angular momentum is a vector and hence there will be infinitely many orbits with the vector pointing in all possible directions. In actuality, this is not true,
- because Bohr model gives incorrect values of angular momentum.
 - because only one of these would have a minimum energy.
 - angular momentum must be in the direction of spin of electron.
 - because electrons go around only in horizontal orbits.
- 12.5** O_2 molecule consists of two oxygen atoms. In the molecule, nuclear force between the nuclei of the two atoms
- is not important because nuclear forces are short-ranged.
 - is as important as electrostatic force for binding the two atoms.
 - cancels the repulsive electrostatic force between the nuclei.
 - is not important because oxygen nucleus have equal number of neutrons and protons.
- 12.6** Two H atoms in the ground state collide inelastically. The maximum amount by which their combined kinetic energy is reduced is
- 10.20 eV
 - 20.40 eV
 - 13.6 eV
 - 27.2 eV
- 12.7** A set of atoms in an excited state decays.
- in general to any of the states with lower energy.
 - into a lower state only when excited by an external electric field.

- (c) all together simultaneously into a lower state.
- (d) to emit photons only when they collide.

MCQ II

- 12.8** An ionised H-molecule consists of an electron and two protons. The protons are separated by a small distance of the order of angstrom. In the ground state,
- (a) the electron would not move in circular orbits.
 - (b) the energy would be $(2)^4$ times that of a H-atom.
 - (c) the electrons, orbit would go arround the protons.
 - (d) the molecule will soon decay in a proton and a H-atom.
- 12.9** Consider aiming a beam of free electrons towards free protons. When they scatter, an electron and a proton cannot combine to produce a H-atom,
- (a) because of energy conservation.
 - (b) without simultaneously releasing energy in the form of radiation.
 - (c) because of momentum conservation.
 - (d) because of angular momentum conservation.
- 12.10** The Bohr model for the spectra of a H-atom
- (a) will not be applicable to hydrogen in the molecular form.
 - (b) will not be applicable as it is for a He-atom.
 - (c) is valid only at room temperature.
 - (d) predicts continuous as well as discrete spectral lines.
- 12.11** The Balmer series for the H-atom can be observed
- (a) if we measure the frequencies of light emitted when an excited atom falls to the ground state.
 - (b) if we measure the frequencies of light emitted due to transitions between excited states and the first excited state.
 - (c) in any transition in a H-atom.
 - (d) as a sequence of frequencies with the higher frequencies getting closely packed.
- 12.12** Let $E_n = \frac{-1}{8\epsilon_0^2} \frac{me^4}{n^2 h^2}$ be the energy of the n^{th} level of H-atom. If all the H-atoms are in the ground state and radiation of frequency $(E_2 - E_1)/h$ falls on it,
- (a) it will not be absorbed at all

- (b) some of atoms will move to the first excited state.
- (c) all atoms will be excited to the $n = 2$ state.
- (d) no atoms will make a transition to the $n = 3$ state.

12.13 The simple Bohr model is not applicable to He^+ atom because

- (a) He^+ is an inert gas.
- (b) He^+ has neutrons in the nucleus.
- (c) He^+ has one more electron.
- (d) electrons are not subject to central forces.

VSA

12.14 The mass of a H-atom is less than the sum of the masses of a proton and electron. Why is this?

12.15 Imagine removing one electron from He^+ and He^2+ . Their energy levels, as worked out on the basis of Bohr model will be very close. Explain why.

12.16 When an electron falls from a higher energy to a lower energy level, the difference in the energies appears in the form of electromagnetic radiation. Why cannot it be emitted as other forms of energy?

12.17 Would the Bohr formula for the H-atom remain unchanged if proton had a charge $(+4/3)e$ and electron a charge $(-3/4)e$, where $e = 1.6 \times 10^{-19}\text{C}$. Give reasons for your answer.

12.18 Consider two different hydrogen atoms. The electron in each atom is in an excited state. Is it possible for the electrons to have different energies but the same orbital angular momentum according to the Bohr model?

SA

12.19 Positronium is just like a H-atom with the proton replaced by the positively charged anti-particle of the electron (called the positron which is as massive as the electron). What would be the ground state energy of positronium?

12.20 Assume that there is no repulsive force between the electrons in an atom but the force between positive and negative charges is given by Coulomb's law as usual. Under such circumstances, calculate the ground state energy of a He-atom.

- 12.21** Using Bohr model, calculate the electric current created by the electron when the H-atom is in the ground state.
- 12.22** Show that the first few frequencies of light that is emitted when electrons fall to the n^{th} level from levels higher than n , are approximate harmonics (i.e. in the ratio 1 : 2: 3...) when $n \gg 1$.
- 12.23** What is the minimum energy that must be given to a H atom in ground state so that it can emit an H_γ line in Balmer series. If the angular momentum of the system is conserved, what would be the angular momentum of such H_γ photon?

LA

- 12.24** The first four spectral lines in the Lyman series of a H-atom are $\lambda = 1218 \text{ \AA}$, 1028 \AA , 974.3 \AA and 951.4 \AA . If instead of Hydrogen, we consider Deuterium, calculate the shift in the wavelength of these lines.
- 12.25** Deuterium was discovered in 1932 by Harold Urey by measuring the small change in wavelength for a particular transition in ^1H and ^2H . This is because, the wavelength of transition depend to a certain extent on the nuclear mass. If nuclear motion is taken into account then the electrons and nucleus revolve around their common centre of mass. Such a system is equivalent to a single particle with a reduced mass μ , revolving around the nucleus at a distance equal to the electron-nucleus separation. Here $\mu = m_e M / (m_e + M)$ where M is the nuclear mass and m_e is the electronic mass. Estimate the percentage difference in wavelength for the 1st line of the Lyman series in ^1H and ^2H . (Mass of ^1H nucleus is $1.6725 \times 10^{-27} \text{ kg}$, Mass of ^2H nucleus is $3.3374 \times 10^{-27} \text{ kg}$, Mass of electron = $9.109 \times 10^{-31} \text{ kg}$.)
- 12.26** If a proton had a radius R and the charge was uniformly distributed, calculate using Bohr theory, the ground state energy of a H-atom when (i) $R = 0.1 \text{ \AA}$, and (ii) $R = 10 \text{ \AA}$.
- 12.27** In the Auger process an atom makes a transition to a lower state without emitting a photon. The excess energy is transferred to an outer electron which may be ejected by the atom. (This is called an Auger electron). Assuming the nucleus to be massive, calculate the kinetic energy of an $n = 4$ Auger electron emitted by Chromium by absorbing the energy from a $n = 2$ to $n = 1$ transition.

12.28 The inverse square law in electrostatics is $|\mathbf{F}| = \frac{e^2}{(4\pi\epsilon_0)r^2}$ for the

force between an electron and a proton. The $\left(\frac{1}{r}\right)$ dependence of

$|\mathbf{F}|$ can be understood in quantum theory as being due to the fact that the ‘particle’ of light (photon) is massless. If photons had a mass m_p , force would be modified to

$$|\mathbf{F}| = \frac{e^2}{(4\pi\epsilon_0)r^2} \left[\frac{1}{r^2} + \frac{\lambda}{r} \right] \cdot \exp(-\lambda r) \text{ where } \lambda = m_p c / h \text{ and } h = \frac{h}{2\pi}.$$

Estimate the change in the ground state energy of a H-atom if m_p were 10^{-6} times the mass of an electron.

12.29 The Bohr model for the H-atom relies on the Coulomb’s law of electrostatics. Coulomb’s law has not directly been verified for very short distances of the order of angstroms. Supposing Coulomb’s law between two opposite charge $+q_1, -q_2$ is modified to

$$|\mathbf{F}| = \frac{q_1 q_2}{(4\pi\epsilon_0)} \frac{1}{r^2}, \quad r \geq R_0$$

$$= \frac{q_1 q_2}{4\pi\epsilon_0} \frac{1}{R_0^2} \left(\frac{R_0}{r} \right)^\epsilon, \quad r \leq R_0$$

Calculate in such a case, the ground state energy of a H-atom, if $\epsilon = 0.1, R_0 = 1\text{\AA}$.

Chapter Thirteen

NUCLEI

MCQ I

13.1 Suppose we consider a large number of containers each containing initially 10000 atoms of a radioactive material with a half life of 1 year. After 1 year,

- (a) all the containers will have 5000 atoms of the material.
- (b) all the containers will contain the same number of atoms of the material but that number will only be approximately 5000.
- (c) the containers will in general have different numbers of the atoms of the material but their average will be close to 5000.
- (d) none of the containers can have more than 5000 atoms.

13.2 The gravitational force between a H-atom and another particle of mass m will be given by Newton's law:

$$F = G \frac{Mm}{r^2}, \text{ where } r \text{ is in km and}$$

(a) $M = m_{\text{proton}} + m_{\text{electron}}$.

(b) $M = m_{\text{proton}} + m_{\text{electron}} - \frac{B}{c^2}$ ($B = 13.6 \text{ eV}$).

- (c) M is not related to the mass of the hydrogen atom.
- (d) $M = m_{\text{proton}} + m_{\text{electron}} - \frac{|V|}{c^2}$ ($|V|$ = magnitude of the potential energy of electron in the H-atom).
- 13.3** When a nucleus in an atom undergoes a radioactive decay, the electronic energy levels of the atom
- do not change for any type of radioactivity .
 - change for α and β radioactivity but not for γ -radioactivity.
 - change for α -radioactivity but not for others.
 - change for β -radioactivity but not for others.
- 13.4** M_x and M_y denote the atomic masses of the parent and the daughter nuclei respectively in a radioactive decay. The Q -value for a β^- decay is Q_1 and that for a β^+ decay is Q_2 . If m_e denotes the mass of an electron, then which of the following statements is correct?
- $Q_1 = (M_x - M_y) c^2$ and $Q_2 = (M_x - M_y - 2m_e)c^2$
 - $Q_1 = (M_x - M_y) c^2$ and $Q_2 = (M_x - M_y)c^2$
 - $Q_1 = (M_x - M_y - 2m_e) c^2$ and $Q_2 = (M_x - M_y + 2m_e)c^2$
 - $Q_1 = (M_x - M_y + 2m_e) c^2$ and $Q_2 = (M_x - M_y + 2m_e)c^2$
- 13.5** Tritium is an isotope of hydrogen whose nucleus Triton contains 2 neutrons and 1 proton. Free neutrons decay into $p + \bar{e} + \bar{\nu}$. If one of the neutrons in Triton decays, it would transform into He^3 nucleus. This does not happen. This is because
- Triton energy is less than that of a He^3 nucleus.
 - the electron created in the beta decay process cannot remain in the nucleus.
 - both the neutrons in triton have to decay simultaneously resulting in a nucleus with 3 protons, which is not a He^3 nucleus.
 - because free neutrons decay due to external perturbations which is absent in a triton nucleus.
- 13.6.** Heavy stable nucle have more neutrons than protons. This is because of the fact that
- neutrons are heavier than protons.
 - electrostatic force between protons are repulsive.
 - neutrons decay into protons through beta decay.
 - nuclear forces between neutrons are weaker than that between protons.
- 13.7** In a nuclear reactor, moderators slow down the neutrons which come out in a fission process. The moderator used have light nuclei. Heavy nuclei will not serve the purpose because

- (a) they will break up.
- (b) elastic collision of neutrons with heavy nuclei will not slow them down.
- (c) the net weight of the reactor would be unbearably high.
- (d) substances with heavy nuclei do not occur in liquid or gaseous state at room temperature.

MCQ II

13.8 Fusion processes, like combining two deuterons to form a He nucleus are impossible at ordinary temperatures and pressure. The reasons for this can be traced to the fact:

- (a) nuclear forces have short range.
- (b) nuclei are positively charged.
- (c) the original nuclei must be completely ionized before fusion can take place.
- (d) the original nuclei must first break up before combining with each other.

13.9 Samples of two radioactive nuclides A and B are taken. λ_A and λ_B are the disintegration constants of A and B respectively. In which of the following cases, the two samples can simultaneously have the same decay rate at any time?

- (a) Initial rate of decay of A is twice the initial rate of decay of B and $\lambda_A = \lambda_B$.
- (b) Initial rate of decay of A is twice the initial rate of decay of B and $\lambda_A > \lambda_B$.
- (c) Initial rate of decay of B is twice the initial rate of decay of A and $\lambda_A > \lambda_B$.
- (d) Initial rate of decay of B is same as the rate of decay of A at $t = 2h$ and $\lambda_B < \lambda_A$.

13.10 The variation of decay rate of two radioactive samples A and B with time is shown in Fig. 13.1.

Which of the following statements are true?

- (a) Decay constant of A is greater than that of B, hence A always decays faster than B.
- (b) Decay constant of B is greater than that of A but its decay rate is always smaller than that of A.
- (c) Decay constant of A is greater than that of B but it does not always decay faster than B.
- (d) Decay constant of B is smaller than that of A but still its decay rate becomes equal to that of A at a later instant.

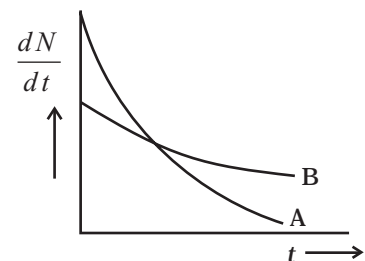

Fig. 13.1

VSA

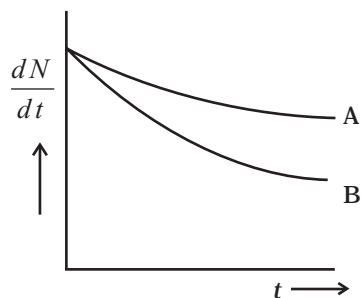

Fig. 13.2

13.11 He_2^3 and He_1^3 nuclei have the same mass number. Do they have the same binding energy?

13.12 Draw a graph showing the variation of decay rate with number of active nuclei.

13.13 Which sample, A or B shown in Fig. 13.2 has shorter mean-life?

13.14 Which one of the following cannot emit radiation and why?

Excited nucleus, excited electron.

13.15 In pair annihilation, an electron and a positron destroy each other to produce gamma radiation. How is the momentum conserved?

SA

13.16 Why do stable nuclei never have more protons than neutrons?

13.17 Consider a radioactive nucleus A which decays to a stable nucleus C through the following sequence:



Here B is an intermediate nuclei which is also radioactive. Considering that there are N_0 atoms of A initially, plot the graph showing the variation of number of atoms of A and B versus time.

13.18 A piece of wood from the ruins of an ancient building was found to have a ^{14}C activity of 12 disintegrations per minute per gram of its carbon content. The ^{14}C activity of the living wood is 16 disintegrations per minute per gram. How long ago did the tree, from which the wooden sample came, die? Given half-life of ^{14}C is 5760 years.

13.19 Are the nucleons fundamental particles, or do they consist of still smaller parts? One way to find out is to probe a nucleon just as Rutherford probed an atom. What should be the kinetic energy of an electron for it to be able to probe a nucleon? Assume the diameter of a nucleon to be approximately 10^{-15} m.

13.20 A nuclide 1 is said to be the mirror isobar of nuclide 2 if $Z_1 = N_2$ and $Z_2 = N_1$. (a) What nuclide is a mirror isobar of $^{23}_{11}\text{Na}$? (b) Which nuclide out of the two mirror isobars have greater binding energy and why?

LA

- 13.21** Sometimes a radioactive nucleus decays into a nucleus which itself is radioactive. An example is :

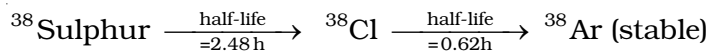

Assume that we start with 1000 ${}^{38}\text{S}$ nuclei at time $t = 0$. The number of ${}^{38}\text{Cl}$ is of count zero at $t = 0$ and will again be zero at $t = \infty$. At what value of t , would the number of counts be a maximum?

- 13.22** Deuteron is a bound state of a neutron and a proton with a binding energy $B = 2.2$ MeV. A γ -ray of energy E is aimed at a deuteron nucleus to try to break it into a (neutron + proton) such that the n and p move in the direction of the incident γ -ray. If $E = B$, show that this cannot happen. Hence calculate how much bigger than B must E be for such a process to happen.
- 13.23** The deuteron is bound by nuclear forces just as H-atom is made up of p and e bound by electrostatic forces. If we consider the force between neutron and proton in deuteron as given in the form of a Coulomb potential but with an effective charge e' :

$$F = \frac{1}{4\pi\epsilon_0} \frac{e'^2}{r}$$

estimate the value of (e'/e) given that the binding energy of a deuteron is 2.2 MeV.

- 13.24** Before the neutrino hypothesis, the beta decay process was thought to be the transition,

$$n \rightarrow p + \bar{e}$$

If this was true, show that if the neutron was at rest, the proton and electron would emerge with fixed energies and calculate them. Experimentally, the electron energy was found to have a large range.

- 13.25** The activity R of an unknown radioactive nuclide is measured at hourly intervals. The results found are tabulated as follows:

t (h)	0	1	2	3	4
R (MBq)	100	35.36	12.51	4.42	1.56

(i) Plot the graph of R versus t and calculate half-life from the graph.

(ii) Plot the graph of $\ln\left(\frac{R}{R_0}\right)$ versus t and obtain the value of half-life from the graph.

13.26 Nuclei with magic no. of proton $Z = 2, 8, 20, 28, 50, 52$ and magic no. of neutrons $N = 2, 8, 20, 28, 50, 82$ and 126 are found to be very stable. (i) Verify this by calculating the proton separation energy S_p for ^{120}Sn ($Z = 50$) and ^{121}Sb ($Z = 51$).

The proton separation energy for a nuclide is the minimum energy required to separate the least tightly bound proton from a nucleus of that nuclide. It is given by

$$S_p = (M_{Z-1, N} + M_H - M_{Z, N}) c^2.$$

Given $^{119}\text{In} = 118.9058\text{u}$, $^{120}\text{Sn} = 119.902199\text{u}$,
 $^{121}\text{Sb} = 120.903824\text{u}$, $^1\text{H} = 1.0078252\text{u}$.

(ii) What does the existence of magic number indicate?

Chapter Fourteen

SEMICONDUCTOR ELECTRONICS MATERIALS, DEVICES AND SIMPLE CIRCUITS

MCQ I

14.1 The conductivity of a semiconductor increases with increase in temperature because

- (a) number density of free current carriers increases.
- (b) relaxation time increases.
- (c) both number density of carriers and relaxation time increase.
- (d) number density of current carriers increases, relaxation time decreases but effect of decrease in relaxation time is much less than increase in number density.

14.2 In Fig. 14.1, V_o is the potential barrier across a p-n junction, when no battery is connected across the junction

- (a) 1 and 3 both correspond to forward bias of junction
- (b) 3 corresponds to forward bias of junction and 1 corresponds to reverse bias of junction
- (c) 1 corresponds to forward bias and 3 corresponds to reverse bias of junction.

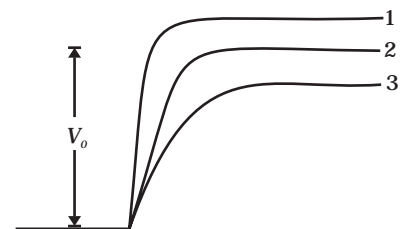

Fig. 14.1

(d) 3 and 1 both correspond to reverse bias of junction.

14.3 In Fig. 14.2, assuming the diodes to be ideal,

- (a) D_1 is forward biased and D_2 is reverse biased and hence current flows from A to B
- (b) D_2 is forward biased and D_1 is reverse biased and hence no current flows from B to A and vice versa.
- (c) D_1 and D_2 are both forward biased and hence current flows from A to B.
- (d) D_1 and D_2 are both reverse biased and hence no current flows from A to B and vice versa.

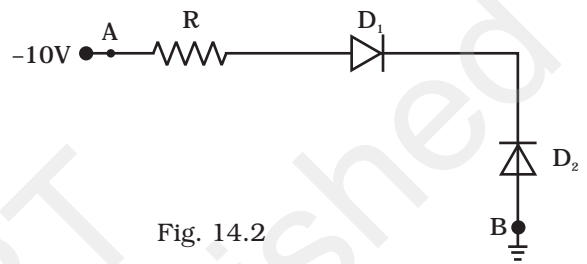

Fig. 14.2

14.4 A 220 V A.C. supply is connected between points A and B (Fig. 14.3). What will be the potential difference V across the capacitor?

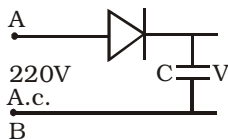

Fig. 14.3

- (a) 220V.
- (b) 110V.
- (c) 0V.
- (d) $220\sqrt{2}$ V.

14.5 Hole is

- (a) an anti-particle of electron.
- (b) a vacancy created when an electron leaves a covalent bond.
- (c) absence of free electrons.
- (d) an artificially created particle.

14.6 The output of the given circuit in Fig. 14.4.

- (a) would be zero at all times.



Fig. 14.4

- (b) would be like a half wave rectifier with positive cycles in output.
- (c) would be like a half wave rectifier with negative cycles in output.
- (d) would be like that of a full wave rectifier.

14.7 In the circuit shown in Fig. 14.5, if the diode forward voltage drop is 0.3 V, the voltage difference between A and B is

- (a) 1.3 V
- (b) 2.3 V
- (c) 0
- (d) 0.5 V

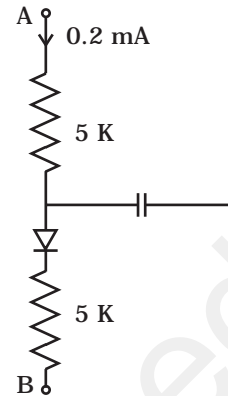

Fig. 14.5

14.8 Truth table for the given circuit (Fig. 14.6) is

(a)

A	B	E
0	0	1
0	1	0
1	0	1
1	1	0

(b)

A	B	E
0	0	1
0	1	0
1	0	0
1	1	1

(c)

A	B	E
0	0	0
0	1	1
1	0	0
1	1	1

(d)

A	B	E
0	0	0
0	1	1
1	0	1
1	1	0

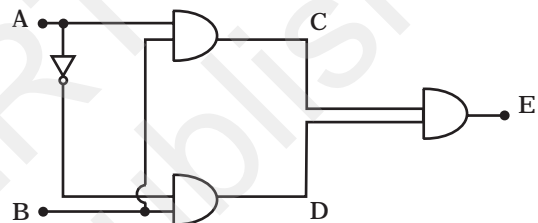

Fig. 14.6

MCQ II

14.9 When an electric field is applied across a semiconductor

- (a) electrons move from lower energy level to higher energy level in the conduction band.
- (b) electrons move from higher energy level to lower energy level in the conduction band.
- (c) holes in the valence band move from higher energy level to lower energy level.
- (d) holes in the valence band move from lower energy level to higher energy level.

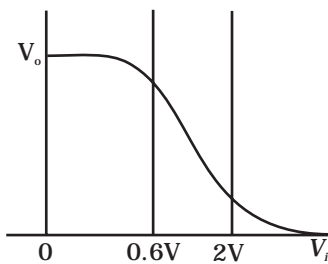

Fig. 14.7

14.10 Consider an npn transistor with its base-emitter junction forward biased and collector base junction reverse biased. Which of the following statements are true?.

- (a) Electrons crossover from emitter to collector.
- (b) Holes move from base to collector.
- (c) Electrons move from emitter to base.
- (d) Electrons from emitter move out of base without going to the collector.

14.11 Figure 14.7 shows the transfer characteristics of a base biased CE transistor. Which of the following statements are true?

- (a) At $V_i = 0.4V$, transistor is in active state.
- (b) At $V_i = 1V$, it can be used as an amplifier.
- (c) At $V_i = 0.5V$, it can be used as a switch turned off.
- (d) At $V_i = 2.5V$, it can be used as a switch turned on.

14.12 In a npn transistor circuit, the collector current is 10mA. If 95 per cent of the electrons emitted reach the collector, which of the following statements are true?

- (a) The emitter current will be 8 mA.
- (b) The emitter current will be 10.53 mA.
- (c) The base current will be 0.53 mA.
- (d) The base current will be 2 mA.

14.13 In the depletion region of a diode

- (a) there are no mobile charges
- (b) equal number of holes and electrons exist, making the region neutral.
- (c) recombination of holes and electrons has taken place.
- (d) immobile charged ions exist.

14.14 What happens during regulation action of a Zener diode?

- (a) The current in and voltage across the Zener remains fixed.
- (b) The current through the series Resistance (R_s) changes.
- (c) The Zener resistance is constant.
- (d) The resistance offered by the Zener changes.

14.15 To reduce the ripples in a rectifier circuit with capacitor filter

- (a) R_L should be increased.
- (b) input frequency should be decreased.
- (c) input frequency should be increased.
- (d) capacitors with high capacitance should be used.

- 14.16** The breakdown in a reverse biased p-n junction diode is more likely to occur due to
- large velocity of the minority charge carriers if the doping concentration is small.
 - large velocity of the minority charge carriers if the doping concentration is large.
 - strong electric field in a depletion region if the doping concentration is small.
 - strong electric field in the depletion region if the doping concentration is large.

VSA

- 14.17** Why are elemental dopants for Silicon or Germanium usually chosen from group XIII or group XV?
- 14.18** Sn, C, and Si, Ge are all group XIV elements. Yet, Sn is a conductor, C is an insulator while Si and Ge are semiconductors. Why?
- 14.19** Can the potential barrier across a p-n junction be measured by simply connecting a voltmeter across the junction?
- 14.20** Draw the output waveform across the resistor (Fig. 14.8).

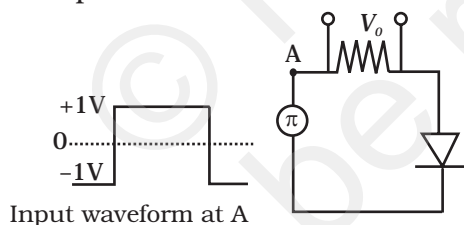

Fig. 14.8

- 14.21** The amplifiers X, Y and Z are connected in series. If the voltage gains of X, Y and Z are 10, 20 and 30, respectively and the input signal is 1 mV peak value, then what is the output signal voltage (peak value)
- if dc supply voltage is 10V?
 - if dc supply voltage is 5V?
- 14.22** In a CE transistor amplifier there is a current and voltage gain associated with the circuit. In other words there is a power gain. Considering power a measure of energy, does the circuit violate conservation of energy?

S.A

14.23

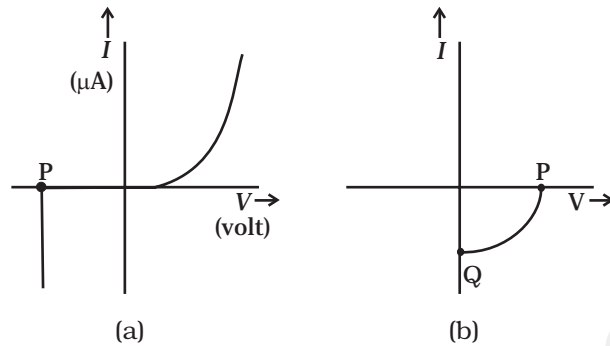

Fig. 14.9

- (i) Name the type of a diode whose characteristics are shown in Fig. 14.9 (A) and Fig. 14.9(B).
- (ii) What does the point P in Fig. (A) represent?
- (iii) What does the points P and Q in Fig. (B) represent?

14.24 Three photo diodes D1, D2 and D3 are made of semiconductors having band gaps of 2.5eV, 2eV and 3eV, respectively. Which ones will be able to detect light of wavelength 6000 \AA ?

14.25 If the resistance R_1 is increased (Fig. 14.10), how will the readings of the ammeter and voltmeter change?

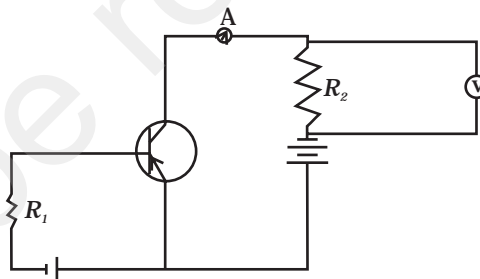

Fig. 14.10

14.26 Two car garages have a common gate which needs to open automatically when a car enters either of the garages or cars enter both. Devise a circuit that resembles this situation using diodes for this situation.

14.27 How would you set up a circuit to obtain NOT gate using a transistor?

14.28 Explain why elemental semiconductor cannot be used to make visible LEDs.

14.29 Write the truth table for the circuit shown in Fig. 14.11.
Name the gate that the circuit resembles.

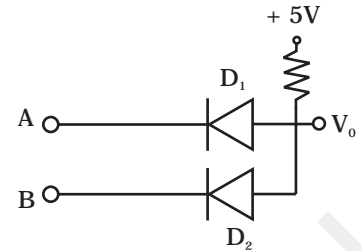

Fig. 14.11

14.30 A Zener of power rating 1 W is to be used as a voltage regulator. If zener has a breakdown of 5V and it has to regulate voltage which fluctuated between 3V and 7V, what should be the value of R_s for safe operation (Fig. 14.12)?

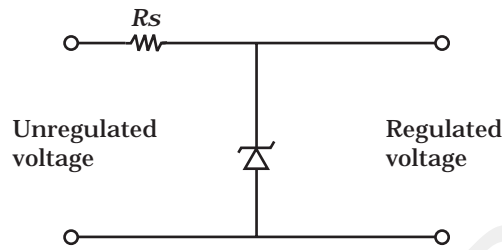

Fig. 14.12

LA

14.31 If each diode in Fig. 14.13 has a forward bias resistance of 25Ω and infinite resistance in reverse bias, what will be the values of the current I_1, I_2, I_3 and I_4 ?

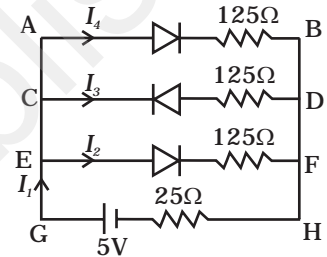

Fig. 14.13

14.32 In the circuit shown in Fig. 14.14, when the input voltage of the base resistance is 10V, V_{be} is zero and V_{ce} is also zero. Find the values of I_b, I_c and β .

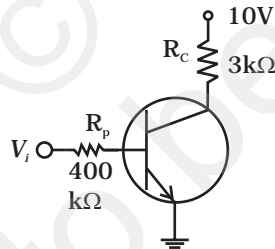

Fig. 14.14

14.33 Draw the output signals C_1 and C_2 in the given combination of gates (Fig. 14.15).

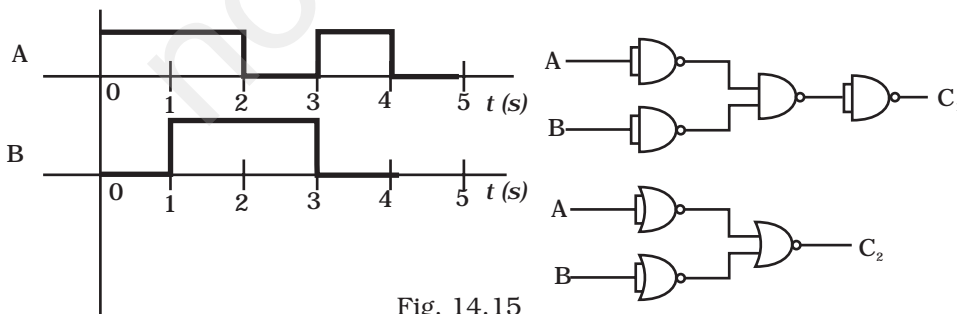

Fig. 14.15

14.34 Consider the circuit arrangement shown in Fig 14.16 (a) for studying input and output characteristics of npn transistor in CE configuration.

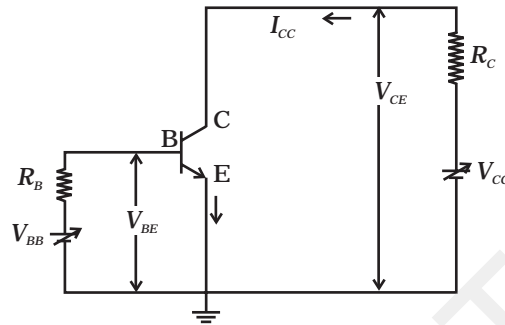

Fig. 14.16 (a)

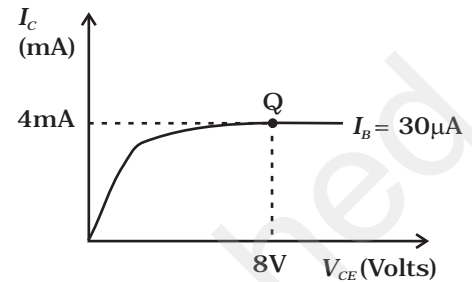

Fig. 14.16 (b)

Select the values of R_B and R_C for a transistor whose $V_{BE} = 0.7$ V, so that the transistor is operating at point Q as shown in the characteristics shown in Fig. 14.16 (b).

Given that the input impedance of the transistor is very small and $V_{CC} = V_{BB} = 16$ V, also find the voltage gain and power gain of circuit making appropriate assumptions.

14.35 Assuming the ideal diode, draw the output waveform for the circuit given in Fig. 14.17. Explain the waveform.

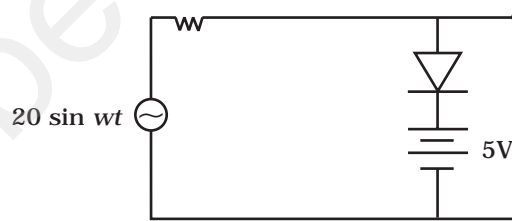

Fig. 14.17

14.36 Suppose a 'n'-type wafer is created by doping Si crystal having 5×10^{28} atoms/m³ with 1ppm concentration of As. On the surface 200 ppm Boron is added to create 'P' region in this wafer. Considering $n_i = 1.5 \times 10^{16}$ m⁻³, (i) Calculate the densities of the charge carriers in the *n* & *p* regions. (ii) Comment which charge carriers would contribute largely for the reverse saturation current when diode is reverse biased.

14.37 An X-OR gate has following truth table:

A	B	Y
0	0	0
0	1	1
1	0	1
1	1	0

It is represented by following logic relation

$$Y = \bar{A}.B + A.\bar{B}$$

Build this gate using AND, OR and NOT gates.

14.38 Consider a box with three terminals on top of it as shown in Fig. 14.18 (a):

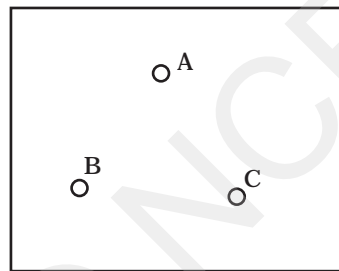

Fig. 14.18 (a)

Three components namely, two germanium diodes and one resistor are connected across these three terminals in some arrangement.

A student performs an experiment in which any two of these three terminals are connected in the circuit shown in Fig. 14.18 (b).

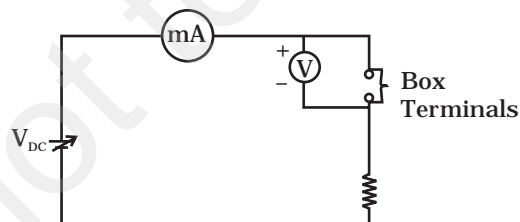

Fig. 14.18 (b)

The student obtains graphs of current-voltage characteristics for unknown combination of components between the two terminals connected in the circuit.

The graphs are

(i) when A is positive and B is negative

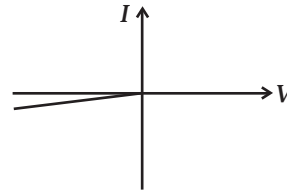

Fig. 14.18 (c)

(ii) when A is negative and B is positive

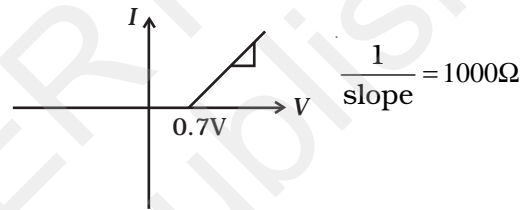

Fig. 14.18 (d)

(iii) When B is negative and C is positive

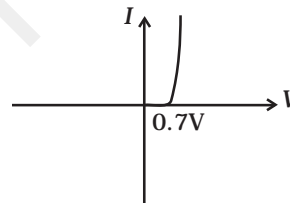

Fig. 14.18 (e)

(iv) When B is positive and C is negative

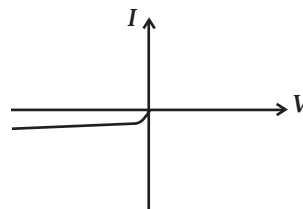

Fig. 14.18 (f)

(v) When A is positive and C is negative

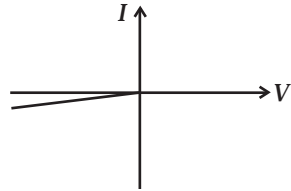

Fig. 14.18 (g)

(vi) When A is negative and C is positive

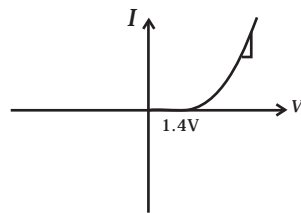

Fig. 14.18 (h)

From these graphs of current - voltage characteristic shown in Fig. 14.18 (c) to (h), determine the arrangement of components between A, B and C.

14.39 For the transistor circuit shown in Fig.14.19, evaluate V_E , R_B , R_E given $I_C = 1 \text{ mA}$, $V_{CE} = 3\text{V}$, $V_{BE} = 0.5 \text{ V}$ and $V_{CC} = 12 \text{ V}$, $\beta = 100$.

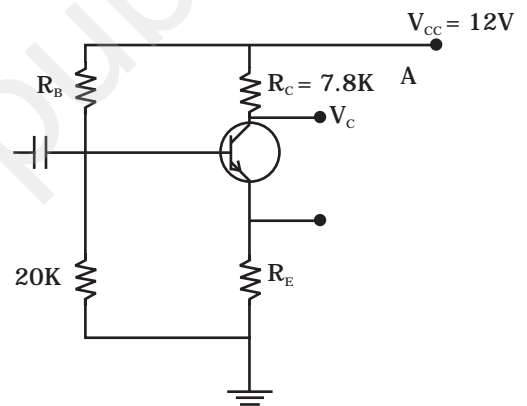

Fig. 14.19

14.40 In the circuit shown in Fig.14.20, find the value of R_C .

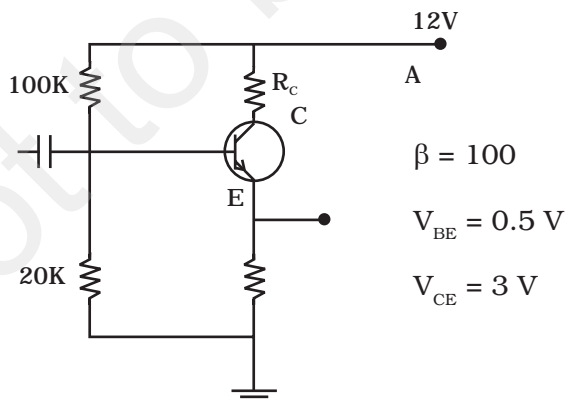

Fig. 14.20

Chapter Fifteen

COMMUNICATION SYSTEMS



MCQ I

- 15.1** Three waves A, B and C of frequencies 1600 kHz, 5 MHz and 60 MHz, respectively are to be transmitted from one place to another. Which of the following is the most appropriate mode of communication:
- (a) A is transmitted via space wave while B and C are transmitted via sky wave.
 - (b) A is transmitted via ground wave, B via sky wave and C via space wave.
 - (c) B and C are transmitted via ground wave while A is transmitted via sky wave.
 - (d) B is transmitted via ground wave while A and C are transmitted via space wave.
- 15.2** A 100m long antenna is mounted on a 500m tall building. The complex can become a transmission tower for waves with λ
- (a) ~ 400 m.
 - (b) ~ 25 m.

- (c) ~ 150 m.
- (d) ~ 2400 m.

15.3 A 1 KW signal is transmitted using a communication channel which provides attenuation at the rate of -2dB per km. If the communication channel has a total length of 5 km, the power of

the signal received is [gain in dB = $10 \log \left(\frac{P_o}{P_i} \right)$]

- (a) 900 W.
 - (b) 100 W.
 - (c) 990 W.
 - (d) 1010 W.
- 15.4** A speech signal of 3 kHz is used to modulate a carrier signal of frequency 1 MHz, using amplitude modulation. The frequencies of the side bands will be
- (a) 1.003 MHz and 0.997 MHz.
 - (b) 3001 kHz and 2997 kHz.
 - (c) 1003 kHz and 1000 kHz.
 - (d) 1 MHz and 0.997 MHz.

15.5 A message signal of frequency ω_m is superposed on a carrier wave of frequency ω_c to get an amplitude modulated wave (AM). The frequency of the AM wave will be

- (a) ω_m .
- (b) ω_c .
- (c) $\frac{\omega_c + \omega_m}{2}$.
- (d) $\frac{\omega_c - \omega_m}{2}$.

15.6 *I-V* characteristics of four devices are shown in Fig. 15.1

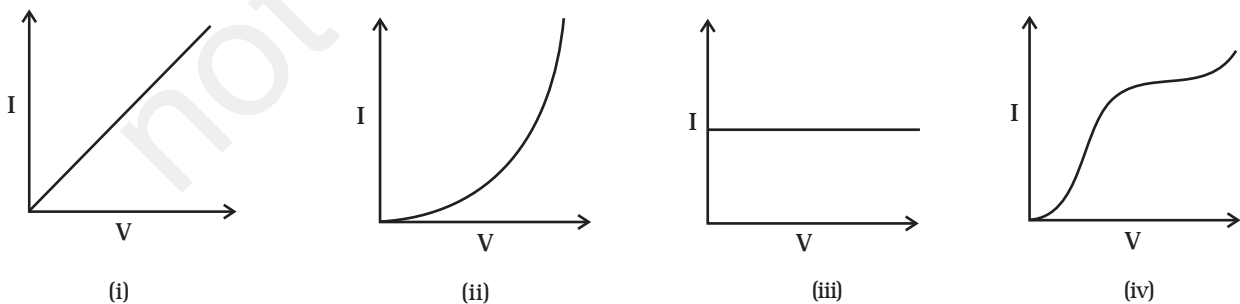

Fig. 15.1

Identify devices that can be used for modulation:

- (a) 'i' and 'iii'.
- (b) only 'iii'.
- (c) 'ii' and some regions of 'iv'.
- (d) All the devices can be used.

15.7 A male voice after modulation-transmission sounds like that of a female to the receiver. The problem is due to

- (a) poor selection of modulation index (selected $0 < m < 1$)
- (b) poor bandwidth selection of amplifiers.
- (c) poor selection of carrier frequency
- (d) loss of energy in transmission.

15.8 A basic communication system consists of

- (A) transmitter.
- (B) information source.
- (C) user of information.
- (D) channel.
- (E) receiver.

Choose the correct sequence in which these are arranged in a basic communication system:

- (a) ABCDE.
- (b) BADEC.
- (c) BDACE.
- (d) BEADC.

15.9 Identify the mathematical expression for amplitude modulated wave:

- (a) $A_c \sin [\{\omega_c + k_1 v_m(t)\}t + \phi]$.
- (b) $A_c \sin \{\omega_c t + \phi + k_2 v_m(t)\}$.
- (c) $\{A_c + k_2 v_m(t)\} \sin (\omega_c t + \phi)$.
- (d) $A_c v_m(t) \sin (\omega_c t + \phi)$.

MCQ II

15.10 An audio signal of 15kHz frequency cannot be transmitted over long distances without modulation because

- (a) the size of the required antenna would be at least 5 km which is not convenient.

- (b) the audio signal can not be transmitted through sky waves.
- (c) the size of the required antenna would be at least 20 km, which is not convenient.
- (d) effective power transmitted would be very low, if the size of the antenna is less than 5 km.

15.11 Audio sine waves of 3 kHz frequency are used to amplitude modulate a carrier signal of 1.5 MHz. Which of the following statements are true?

- (a) The side band frequencies are 1506 kHz and 1494 kHz.
- (b) The bandwidth required for amplitude modulation is 6kHz.
- (c) The bandwidth required for amplitude modulation is 3 MHz.
- (d) The side band frequencies are 1503 kHz and 1497 kHz.

15.12 A TV trasmission tower has a height of 240 m. Signals broadcast from this tower will be received by LOS communication at a distance of (assume the radius of earth to be 6.4×10^6 m)

- (a) 100 km.
- (b) 24 km.
- (c) 55 km.
- (d) 50 km.

15.13 The frequency response curve (Fig. 15.2) for the filter circuit used for production of AM wave should be

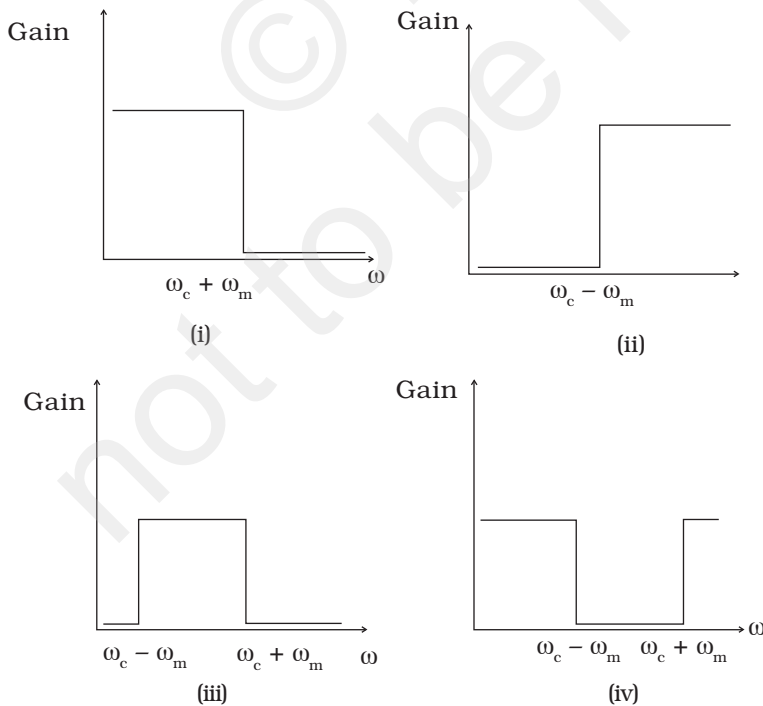

Fig. 15.2

- (a) (i) followed by (ii).
- (b) (ii) followed by (i).
- (c) (iii).
- (d) (iv).

15.14 In amplitude modulation, the modulation index m , is kept less than or equal to 1 because

- (a) $m > 1$, will result in interference between carrier frequency and message frequency, resulting into distortion.
- (b) $m > 1$ will result in overlapping of both side bands resulting into loss of information.
- (c) $m > 1$ will result in change in phase between carrier signal and message signal.
- (d) $m > 1$ indicates amplitude of message signal greater than amplitude of carrier signal resulting into distortion.

VSA

15.15 Which of the following would produce analog signals and which would produce digital signals?

- (i) A vibrating tuning fork.
- (ii) Musical sound due to a vibrating sitar string.
- (iii) Light pulse.
- (iv) Output of NAND gate.

15.16 Would sky waves be suitable for transmission of TV signals of 60 MHz frequency?

15.17 Two waves A and B of frequencies 2 MHz and 3 MHz, respectively are beamed in the same direction for communication via sky wave. Which one of these is likely to travel longer distance in the ionosphere before suffering total internal reflection?

15.18 The maximum amplitude of an A.M. wave is found to be 15 V while its minimum amplitude is found to be 3 V. What is the modulation index?

15.19 Compute the LC product of a tuned amplifier circuit required to generate a carrier wave of 1 MHz for amplitude modulation.

15.20 Why is a AM signal likely to be more noisy than a FM signal upon transmission through a channel?

SA

- 15.21** Figure 15.3 shows a communication system. What is the output power when input signal is of 1.01mW? (gain in dB = $10 \log_{10} (P_o/P_i)$).

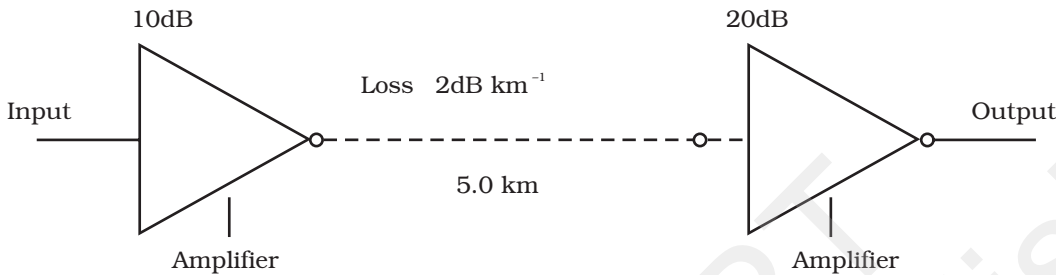

Fig. 15.3

- 15.22** A TV transmission tower antenna is at a height of 20 m. How much service area can it cover if the receiving antenna is (i) at ground level, (ii) at a height of 25 m? Calculate the percentage increase in area covered in case (ii) relative to case (i).
- 15.23** If the whole earth is to be connected by LOS communication using space waves (no restriction of antenna size or tower height), what is the minimum number of antennas required? Calculate the tower height of these antennas in terms of earth's radius?
- 15.24** The maximum frequency for reflection of sky waves from a certain layer of the ionosphere is found to be $f_{\text{max}} = 9(N_{\text{max}})^{1/2}$, where N_{max} is the maximum electron density at that layer of the ionosphere. On a certain day it is observed that signals of frequencies higher than 5MHz are not received by reflection from the F_1 layer of the ionosphere while signals of frequencies higher than 8MHz are not received by reflection from the F_2 layer of the ionosphere. Estimate the maximum electron densities of the F_1 and F_2 layers on that day.
- 15.25** On radiating (sending out) an AM modulated signal, the total radiated power is due to energy carried by ω_c , $\omega_c - \omega_m$ & $\omega_c + \omega_m$. Suggest ways to minimise cost of radiation without compromising on information.

LA

- 15.26** (i) The intensity of a light pulse travelling along a communication channel decreases exponentially with distance x according to the relation $I = I_0 e^{-\alpha x}$, where I_0 is the intensity at $x = 0$ and α is the attenuation constant.

Show that the intensity reduces by 75 per cent after a distance

of $\left(\frac{\ln 4}{\alpha}\right)$

- (ii) Attenuation of a signal can be expressed in decibel (dB)

according to the relation $\text{dB} = 10 \log_{10} \left(\frac{I}{I_0}\right)$. What is the attenuation in dB/km for an optical fibre in which the intensity falls by 50 per cent over a distance of 50 km?

- 15.27** A 50 MHz sky wave takes 4.04 ms to reach a receiver via re-transmission from a satellite 600 km above earth's surface. Assuming re-transmission time by satellite negligible, find the distance between source and receiver. If communication between the two was to be done by Line of Sight (LOS) method, what should size and placement of receiving and transmitting antenna be?

- 15.28** An amplitude modulated wave is as shown in Fig. 15.4. Calculate (i) the percentage modulation, (ii) peak carrier voltage and (iii) peak value of information voltage.

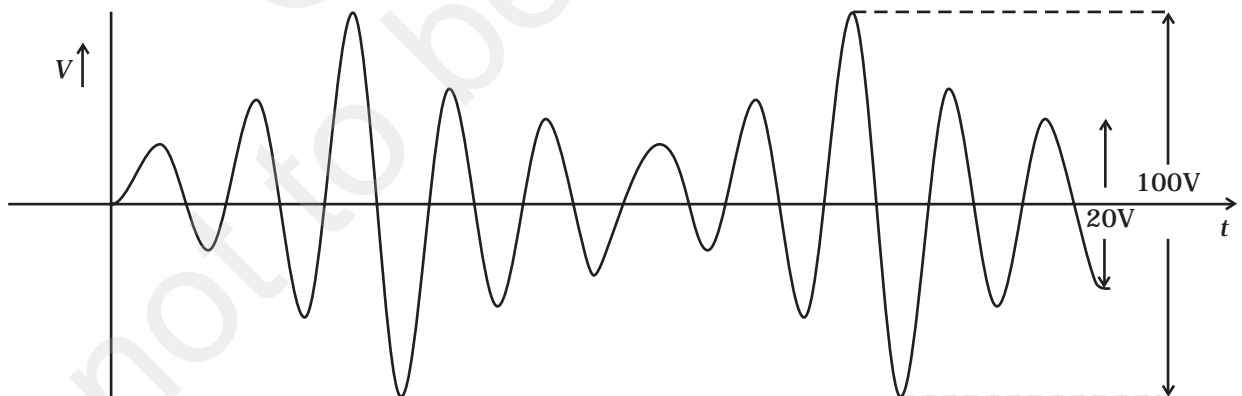

Fig. 15.4

- 15.29** (i) Draw the plot of amplitude versus ' ω ' for an amplitude modulated wave whose carrier wave (ω_c) is carrying two modulating signals, ω_1 and ω_2 ($\omega_2 > \omega_1$). [Hint: Follow derivation from Eq 15.6 of NCERT Textbook of XII]
- (ii) Is the plot symmetrical about ω_c ? Comment especially about plot in region $\omega < \omega_c$.
- (iii) Extrapolate and predict the problems one can expect if more waves are to be modulated.
- (iv) Suggest solutions to the above problem. In the process can one understand another advantage of modulation in terms of bandwidth?
- 15.30** An audio signal is modulated by a carrier wave of 20MHz such that the bandwidth required for modulation is 3kHz. Could this wave be demodulated by a diode detector which has the values of R and C as
- (i) $R = 1 \text{ k}\Omega$, $C = 0.01\mu\text{F}$.
- (ii) $R = 10 \text{ k}\Omega$, $C = 0.01\mu\text{F}$.
- (iii) $R = 10 \text{ k}\Omega$, $C = 0.1\mu\text{F}$.

ANSWERS

Chapter 1

- 1.1 (a)
1.2 (a)
1.3 (d)
1.4 (b)
1.5 (c)
1.6 (a)
1.7 (a)
1.8 (c), (d)
1.9 (b), (d)
1.10 (b), (d)
1.11 (c), (d)
1.12 (a), (c).
1.13 (a), (b), (c) and (d).
1.14 Zero.
1.15 (i) $\frac{-Q}{4\pi R_1^2}$ (ii) $\frac{Q}{4\pi R_2^2}$
1.16 The electric fields bind the atoms to neutral entity. Fields are caused by excess charges. There can be no excess charge on the inter surface of an isolated conductor.
1.17 No, the field may be normal. However, the converse is true.

1.18

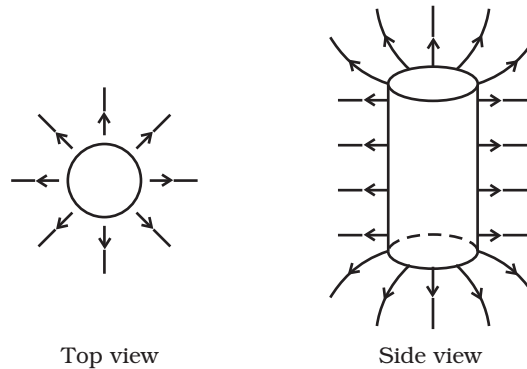

1.19 (i) $\frac{q}{8\epsilon_0}$ (ii) $\frac{q}{4\epsilon_0}$ (iii) $\frac{q}{2\epsilon_0}$ (iv) $\frac{q}{2\epsilon_0}$

1.20 1 Molar mass M of Al has $N_A = 6.023 \times 10^{23}$ atoms.

$\therefore m =$ mass of Al paisa coin has $N = N_A \frac{m}{M}$ atoms

Now, $Z_{Al} = 13$, $M_{Al} = 26.9815\text{g}$

Hence $N = 6.02 \times 10^{23} \text{ atoms/mol} \times \frac{0.75}{26.9815\text{g/mol}}$
 $= 1.6733 \times 10^{22}$ atoms

$\therefore q =$ +ve charge in paisa $= NZe$
 $= (1.67 \times 10^{22})(13)(1.60 \times 10^{-19}\text{C})$
 $= 3.48 \times 10^4 \text{ C.}$

$q = 34.8 \text{ kC}$ of \pm ve charge.

This is an enormous amount of charge. Thus we see that ordinary neutral matter contains enormous amount of \pm charges.

1.21 (i) $F_1 = \frac{|q|^2}{4\pi\epsilon_0 r_1^2} = \left(8.99 \times 10^9 \frac{\text{Nm}^2}{\text{C}^2}\right) \frac{(3.48 \times 10^4 \text{C})^2}{10^{-4}\text{m}^2} = 1.1 \times 10^{23} \text{N}$

(ii) $\frac{F_2}{F_1} = \frac{r_1^2}{r_2^2} = \frac{(10^{-2}\text{m})^2}{(10^2\text{m})^2} = 10^{-8} \Rightarrow F_2 = F_1 \times 10^{-8} = 1.1 \times 10^{15} \text{N}$

(iii) $\frac{F_3}{F_1} = \frac{r_1^2}{r_3^2} = \frac{(10^{-2}\text{m})^2}{(10^6\text{m})^2} = 10^{-16}$

$F_3 = 10^{-16} F_1 = 1.1 \times 10^7 \text{N.}$

Conclusion: When separated as point charges these charges exert an enormous force. It is not easy to disturb electrical neutrality.

Exemplar Problems–Physics

- 1.22 (i) Zero, from symmetry.
 (ii) Removing a +ve Cs ion is equivalent to adding singly charged -ve Cs ion at that location.
 Net force then is

$$F = \frac{e^2}{4\pi\epsilon_0 r^2}$$

where r = distance between the Cl ion and a Cs ion.

$$= \sqrt{(0.20)^2 + (0.20)^2 + (0.20)^2} \times 10^{-9} = \sqrt{3(0.20)^2} \times 10^{-9}$$

$$= 0.346 \times 10^{-9} \text{ m}$$

$$\text{Hence, } F = \frac{(8.99 \times 10^9)(1.6 \times 10^{-19})^2}{(0.346 \times 10^{-9})^2} = 192 \times 10^{-11}$$

$$= 1.92 \times 10^{-9} \text{ N}$$

Ans $1.92 \times 10^{-9} \text{ N}$, directed from A to Cl^-

- 1.23 At P: on $2q$, Force due to q is to the left and that due to $-3q$ is to the right.

$$\therefore \frac{2q^2}{4\pi\epsilon_0 x^2} = \frac{6q^2}{4\pi\epsilon_0 (d+x)^2}$$

$$\therefore (d+x)^2 = 3x^2$$

$$\therefore 2x^2 - 2dx - d^2 = 0$$

$$x = \frac{d}{2} \pm \frac{\sqrt{3}d}{2}$$

(-ve sign would be between q and $-3q$ and hence is unacceptable.)

$$x = \frac{d}{2} + \frac{\sqrt{3}d}{2} = \frac{d}{2}(1 + \sqrt{3}) \text{ to the left of } q.$$

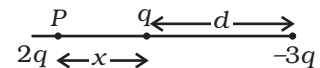

- 1.24 (a) Charges A and C are positive since lines of force emanate from them.
 (b) Charge C has the largest magnitude since maximum number of field lines are associated with it.
 (c) (i) near A. There is no neutral point between a positive and a negative charge. A neutral point may exist between two like charges. From the figure we see that a neutral point exists between charges A and C. Also between two like charges the neutral point is closer to the charge with smaller magnitude. Thus, electric field is zero near charge A.

- 1.25 (a) (i) zero (ii) $\frac{1}{4\pi\epsilon_0} \frac{q}{r^2}$ along \overline{OA} (iii) $\frac{1}{4\pi\epsilon_0} \frac{2q}{r^2}$ along \overline{OA}

- (b) same as (a).

- 1.26 (a) Let the Universe have a radius R . Assume that the hydrogen atoms are uniformly distributed. The charge on each hydrogen atom is $e_H = -(1 + y)e + e = -ye = |ye|$

The mass of each hydrogen atom is $\sim m_p$ (mass of proton). Expansion starts if the Coulomb repulsion on a hydrogen atom, at R , is larger than the gravitational attraction.

Let the Electric Field at R be \mathbf{E} . Then

$$4\pi R^2 E = \frac{4}{3\epsilon_0} \pi R^3 N |ye| \quad (\text{Gauss's law})$$

$$\mathbf{E}(R) = \frac{1}{3} \frac{N |ye|}{\epsilon_0} R \hat{\mathbf{r}}$$

Let the gravitational field at R be G_R . Then

$$-4\pi R^2 G_R = 4 \pi G m_p \frac{4}{3} \pi R^3 N$$

$$G_R = -\frac{4}{3} \pi G m_p N R$$

$$\mathbf{G}_R(\mathbf{R}) = -\frac{4}{3} \pi G m_p N R \hat{\mathbf{r}}$$

Thus the Coulombic force on a hydrogen atom at R is

$$ye\mathbf{E}(R) = \frac{1}{3} \frac{Ny^2e^2}{\epsilon_0} R \hat{\mathbf{r}}$$

The gravitational force on this atom is

$$m_p \mathbf{G}_R(R) = -\frac{4\pi}{3} GNm_p^2 R \hat{\mathbf{r}}$$

The net force on the atom is

$$\mathbf{F} = \left(\frac{1}{3} \frac{Ny^2e^2}{\epsilon_0} R - \frac{4\pi}{3} GNm_p^2 R \right) \hat{\mathbf{r}}$$

The critical value is when

$$\frac{1}{3} \frac{Ny_c^2e^2}{\epsilon_0} R = \frac{4\pi}{3} GNm_p^2 R$$

$$\Rightarrow y_c^2 = 4\pi\epsilon_0 G \frac{m_p^2}{e^2}$$

$$\square \frac{7 \times 10^{-11} \times 1.8^2 \times 10^6 \times 81 \times 10^{-62}}{9 \times 10^9 \times 1.6^2 \times 10^{-38}}$$

$$\square 63 \times 10^{-38}$$

$$\therefore y_c \square 8 \times 10^{-19} \square 10^{-18}$$

- (b) Because of the net force, the hydrogen atom experiences an acceleration such that

$$m_p \frac{d^2 R}{dt^2} = \left(\frac{1}{3} \frac{Ny^2 e^2}{e_o} R - \frac{4p}{3} GNm_p^2 R \right)$$

$$\text{Or, } \frac{d^2 R}{dt^2} = \alpha^2 R \text{ where } \alpha^2 = \frac{1}{m_p} \left(\frac{1}{3} \frac{Ny^2 e^2}{e_o} - \frac{4p}{3} GNm_p^2 \right)$$

This has a solution $R = Ae^{\alpha t} + Be^{-\alpha t}$

As we are seeking an expansion, $B = 0$.

$$\therefore R = Ae^{\alpha t}$$

$$\Rightarrow \dot{R} = \alpha Ae^{\alpha t} = \alpha R$$

Thus, the velocity is proportional to the distance from the centre.

- 1.27 (a) The symmetry of the problem suggests that the electric field is radial. For points $r < R$, consider a spherical Gaussian surfaces. Then on the surface

$$\oiint \mathbf{E}_r \cdot d\mathbf{S} = \frac{1}{\epsilon_o} \int_V \rho dv$$

$$\begin{aligned} 4\pi r^2 E_r &= \frac{1}{\epsilon_o} 4\pi k \int_0^r r'^3 dr' \\ &= \frac{1}{\epsilon_o} \frac{4\pi k}{4} r^4 \end{aligned}$$

$$\therefore E_r = \frac{1}{4\epsilon_o} kr^2$$

$$\mathbf{E}(r) = \frac{1}{4\epsilon_o} kr^2 \hat{\mathbf{r}}$$

For points $r > R$, consider a spherical Gaussian surfaces' of radius r ,

$$\oiint \mathbf{E}_r \cdot d\mathbf{S} = \frac{1}{\epsilon_o} \int_V \rho dv$$

$$\begin{aligned} 4\pi r^2 E_r &= \frac{4\pi k}{\epsilon_o} \int_0^R r^3 dr \\ &= \frac{4\pi k}{\epsilon_o} \frac{R^4}{4} \end{aligned}$$

$$\therefore E_r = \frac{k}{4\epsilon_o} \frac{R^4}{r^2}$$

$$\mathbf{E}(r) = (k / 4\epsilon_o) (R^4 / r^2) \hat{\mathbf{r}}$$

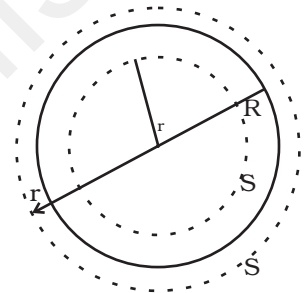

- (b) The two protons must be on the opposite sides of the centre along a diameter. Suppose the protons are at a distance r from the centre.

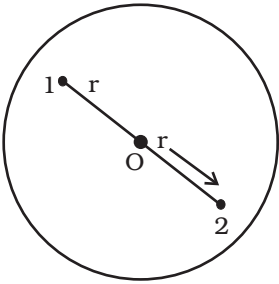

$$\text{Now, } 4\pi \int_0^R kr^3 dr = 2e$$

$$\therefore \frac{4\pi k}{4} R^4 = 2e$$

$$\therefore k = \frac{2e}{\pi R^4}$$

Consider the forces on proton 1. The attractive force due to the charge distribution is

$$-e\mathbf{E}_r = -\frac{e}{4\epsilon_0} kr^2 \hat{\mathbf{r}} = -\frac{2e^2}{4\pi\epsilon_0 R^4} r^2 \hat{\mathbf{r}}$$

The repulsive force is $\frac{e^2}{4\pi\epsilon_0 (2r)^2} \hat{\mathbf{r}}$

Net force is $\left(\frac{e^2}{4\pi\epsilon_0 4r^2} - \frac{2e^2}{4\pi\epsilon_0 R^4} r^2 \right) \hat{\mathbf{r}}$

This is zero such that

$$\frac{e^2}{16\pi\epsilon_0 r^2} = \frac{2e^2}{4\pi\epsilon_0 R^4} r^2$$

$$\text{Or, } r^4 = \frac{4R^4}{32} = \frac{R^4}{8}$$

$$\Rightarrow r = \frac{R}{(8)^{1/4}}$$

Thus, the protons must be at a distance $r = \frac{R}{\sqrt[4]{8}}$ from the centre.

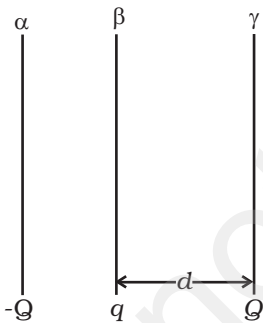

- 1.28 (a) The electric field at γ due to plate α is $-\frac{Q}{S2\epsilon_0} \hat{\mathbf{x}}$

The electric field at γ due to plate β is $\frac{q}{S2\epsilon_0} \hat{\mathbf{x}}$

Hence, the net electric field is

$$\mathbf{E}_1 = \frac{(Q - q)}{2\epsilon_0 S} (-\hat{\mathbf{x}})$$

- (b) During the collision plates β & γ are together and hence must be at one potential. Suppose the charge on β is q_1 and on γ is q_2 . Consider a point O. The electric field here must be zero.

Electric field at O due to $\alpha = -\frac{Q}{2\epsilon_0 S} \hat{\mathbf{x}}$

Electric field at O due to $\beta = -\frac{q_1}{2\epsilon_0 S} \hat{x}$

Electric Field at O due to $\gamma = -\frac{q_2}{2\epsilon_0 S} \hat{x}$

$$\therefore \frac{-(Q+q_2)}{2\epsilon_0 S} + \frac{q_1}{2\epsilon_0 S} = 0$$

$$\Rightarrow q_1 - q_2 = Q$$

Further, $q_1 + q_2 = Q + q$

$$\Rightarrow q_1 = Q + q/2$$

and $q_2 = q/2$

Thus the charge on β and γ are $Q + q/2$ and $q/2$, respectively.

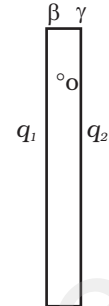

- (c) Let the velocity be v at the distance d after the collision. If m is the mass of the plate γ , then the gain in K.E. over the round trip must be equal to the work done by the electric field. After the collision, the electric field at γ is

$$\mathbf{E}_2 = -\frac{Q}{2\epsilon_0 S} \hat{x} + \frac{(Q+q/2)}{2\epsilon_0 S} \hat{x} = \frac{q/2}{2\epsilon_0 S} \hat{x}$$

The work done when the plate γ is released till the collision is $F_1 d$ where F_1 is the force on plate γ .

The work done after the collision till it reaches d is $F_2 d$ where F_2 is the force on plate γ .

$$F_1 = E_1 Q = \frac{(Q-q)Q}{2\epsilon_0 S}$$

$$\text{and } F_2 = E_2 q/2 = \frac{(q/2)^2}{2\epsilon_0 S}$$

\therefore Total work done is

$$\frac{1}{2\epsilon_0 S} [(Q-q)Q + (q/2)^2] d = \frac{1}{2\epsilon_0 S} (Q - q/2)^2 d$$

$$\Rightarrow (1/2)mv^2 = \frac{d}{2\epsilon_0 S} (Q - q/2)^2$$

$$\therefore v = (Q - q/2) \left(\frac{d}{m\epsilon_0 S} \right)^{1/2}$$

1.29 (i) $F = \frac{Qq}{r^2} = 1 \text{ dyne} = \frac{[1 \text{ esu of charge}]^2}{[1 \text{ cm}]^2}$

Or,

1 esu of charge = $1 \text{ (dyne)}^{1/2} \text{ (cm)}$

Hence, $[1 \text{ esu of charge}] = [F]^{1/2} L = [MLT^{-2}]^{1/2} L = M^{1/2} L^{3/2} T^{-1}$

$[1 \text{ esu of charge}] = M^{1/2} L^{3/2} T^{-1}$

Thus charge in cgs unit is expressed as fractional powers (1/2) of M and (3/2) of L.

- (ii) Consider the coulomb force on two charges, each of magnitude 1 esu of charge separated by a distance of 1 cm:
 The force is then 1 dyne = 10^{-5} N.
 This situation is equivalent to two charges of magnitude x C separated by 10^{-2} m.
 This gives:

$$F = \frac{1}{4\pi\epsilon_0} \cdot \frac{x^2}{10^{-4}}$$

which should be 1 dyne = 10^{-5} N. Thus

$$\frac{1}{4\pi\epsilon_0} \cdot \frac{x^2}{10^{-4}} = 10^{-5} \Rightarrow \frac{1}{4\pi\epsilon_0} = \frac{10^{-9} \text{ Nm}^2}{x^2 \text{ C}^2}$$

With $x = \frac{1}{[3] \times 10^9}$, this yields

$$\frac{1}{4\pi\epsilon_0} = 10^{-9} \times [3]^2 \times 10^{18} = [3]^2 \times 10^9 \frac{\text{Nm}^2}{\text{C}^2}$$

With $[3] \rightarrow 2.99792458$, we get

$$\frac{1}{4\pi\epsilon_0} = 8.98755 \dots \times 10^9 \frac{\text{Nm}^2}{\text{C}^2} \text{ exactly}$$

1.30 Net force F on q towards the centre O

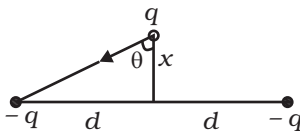

$$F = 2 \frac{q^2}{4\pi\epsilon_0 r^2} \cos \theta = - \frac{2q^2}{4\pi\epsilon_0 r^2} \cdot \frac{x}{r}$$

$$F = \frac{-2q^2}{4\pi\epsilon_0} \frac{x}{(d^2 + x^2)^{3/2}}$$

$$\approx \frac{-2q^2}{4\pi\epsilon_0 d^3} x = -k \text{ for } x \ll d.$$

Thus, the force on the third charge q is proportional to the displacement and is towards the centre of the two other charges. Therefore, the motion of the third charge is harmonic with frequency

$$\omega = \sqrt{\frac{2q^2}{4\pi\epsilon_0 d^3 m}} = \sqrt{\frac{k}{m}}$$

$$\text{and hence } T = \frac{2\pi}{\omega} \left[\frac{8\pi^3 \epsilon_0 m d^3}{q^2} \right]^{1/2}.$$

- 1.31 (a) Slight push on q along the axis of the ring gives rise to the situation shown in Fig (b). A and B are two points on the ring at the end of a diameter.

Force on q due to line elements $\frac{-Q}{2\pi R}$ at A and B is

$$F_{A+B} = 2 \cdot \frac{-Q}{2\pi R} \cdot q \cdot \frac{1}{4\pi\epsilon_0} \cdot \frac{1}{r^2} \cdot \cos\theta$$

$$= \frac{-Qq}{\pi R \cdot 4\pi\epsilon_0} \cdot \frac{1}{(z^2 + R^2)} \cdot \frac{z}{(z^2 + R^2)^{1/2}}$$

Total force due to ring on $q = (F_{A+B})(\pi R)$

$$= \frac{-Qq}{4\pi\epsilon_0} \frac{z}{(z^2 + R^2)^{3/2}}$$

□ $\frac{-Qq}{4\pi\epsilon_0}$ for $z \ll R$

Thus, the force is proportional to negative of displacement under such forces is harmonic.

(b) From (a)

$$m \frac{d^2 z}{dt^2} = -\frac{Qqz}{4\pi\epsilon_0 R^3} \text{ or } \frac{d^2 z}{dt^2} = -\frac{Qq}{4\pi\epsilon_0 m R^3} z$$

That is, $\omega^2 = \frac{Qq}{4\pi\epsilon_0 m R^3}$. Hence $T = 2\pi \sqrt{\frac{4\pi\epsilon_0 m R^3}{Qq}}$

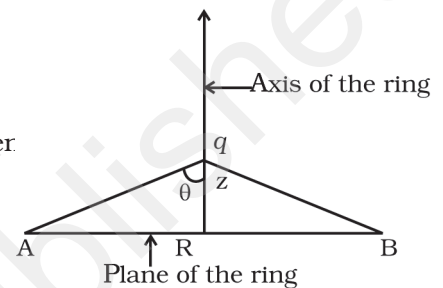
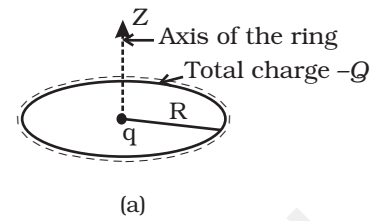

Chapter 2

- 2.1 (d)
- 2.2 (c)
- 2.3 (c)
- 2.4 (c)
- 2.5 (a)
- 2.6 (c)
- 2.7 (b), (c), (d)
- 2.8 (a), (b), (c)
- 2.9 (b), (c)
- 2.10 (b), (c)
- 2.11 (a), (d)
- 2.12 (a), (b)
- 2.13 (c) and (d)

- 2.14 More.
- 2.15 Higher potential.
- 2.16 Yes, if the sizes are different.
- 2.17 No.
- 2.18 As electric field is conservative, work done will be zero in both the cases.
- 2.19 Suppose this were not true. The potential just inside the surface would be different from that at the surface resulting in a potential gradient. This would mean that there are field lines pointing inwards or outwards from the surface. These lines cannot at the other end be again on the surface, since the surface is equipotential. Thus, this is possible only if the other end of the lines are at charges inside, contradicting the premise. Hence, the entire volume inside must be at the same potential.
- 2.20 C will decrease

Energy stored = $\frac{1}{2}CV^2$ and hence will increase.

Electric field will increase.

Charge stored will remain the same.

V will increase.

- 2.21 Consider any path from the charged conductor to the uncharged conductor along the electric field. The potential will continually decrease along this path. A second path from the uncharged conductor to infinity will again continually lower the potential further. Hence this result.

2.22
$$U = \frac{-qQ}{4\pi\epsilon_0 R\sqrt{1+z^2/R^2}}$$

The variation of potential energy with z is shown in the figure.

The charge $-q$ displaced would perform oscillations. We cannot conclude anything just by looking at the graph.

2.23
$$V = \frac{1}{4\pi\epsilon_0} \frac{Q}{\sqrt{R^2+z^2}}$$

- 2.24 To find the potential at distance r from the line consider the electric field. We note that from symmetry the field lines must be radially outward. Draw a cylindrical Gaussian surface of radius r and length l . Then

$$\oint \mathbf{E} \cdot d\mathbf{S} = \frac{1}{\epsilon_0} \lambda l$$

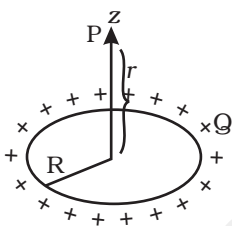
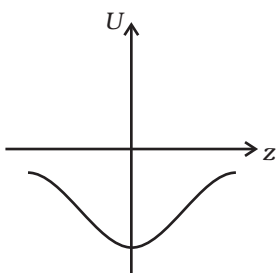
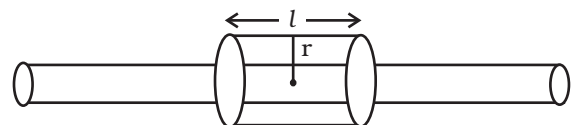

Exemplar Problems–Physics

$$\text{Or } E_r 2\pi r l = \frac{1}{\epsilon_0} \lambda l$$

$$\Rightarrow E_r = \frac{\lambda}{2\pi\epsilon_0 r}$$

Hence, if r_0 is the radius,

$$V(r) - V(r_0) = - \int_{r_0}^r \mathbf{E} \cdot d\mathbf{l} = \frac{\lambda}{2\pi\epsilon_0} \ln \frac{r_0}{r}$$

For a given V ,

$$\ln \frac{r}{r_0} = - \frac{2\pi\epsilon_0}{\lambda} [V(r) - V(r_0)]$$

$$\Rightarrow r = r_0 e^{-2\pi\epsilon_0 V(r_0) / \lambda} e^{+2\pi\epsilon_0 V(r) / \lambda}$$

The equipotential surfaces are cylinders of radius

$$r = r_0 e^{-2\pi\epsilon_0 [V(r) - V(r_0)] / \lambda}$$

- 2.25 Let the plane be at a distance x from the origin. The potential at the point P is

$$\frac{1}{4\pi\epsilon_0} \frac{q}{[(x+d/2)^2 + h^2]^{1/2}} - \frac{1}{4\pi\epsilon_0} \frac{q}{[(x-d/2)^2 + h^2]^{1/2}}$$

If this is to be zero,

$$\frac{1}{[(x+d/2)^2 + h^2]^{1/2}} = \frac{1}{[(x-d/2)^2 + h^2]^{1/2}}$$

$$\text{Or, } (x-d/2)^2 + h^2 = (x+d/2)^2 + h^2$$

$$\Rightarrow x^2 - dx + d^2/4 = x^2 + dx + d^2/4$$

$$\text{Or, } 2dx = 0$$

$$\Rightarrow x = 0$$

The equation is that of a plane $x = 0$.

- 2.26 Let the final voltage be U : If C is the capacitance of the capacitor without the dielectric, then the charge on the capacitor is

$$Q_1 = CU$$

The capacitor with the dielectric has a capacitance ϵC . Hence the charge on the capacitor is

$$Q_2 = \epsilon U = \alpha CU^2$$

The initial charge on the capacitor that was charged is

$$Q_0 = CU_0$$

From the conservation of charges,

$$Q_0 = Q_1 + Q_2$$

$$\text{Or, } CU_0 = CU + \alpha CU^2$$

$$\Rightarrow \alpha U^2 + U - U_0 = 0$$

$$\therefore U = \frac{-1 \pm \sqrt{1 + 4\alpha U_0}}{2\alpha}$$

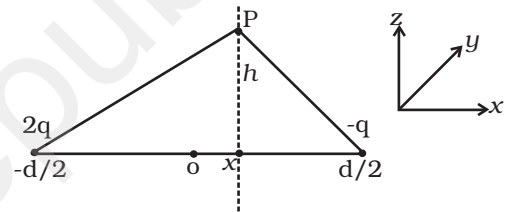

$$= \frac{-1 \pm \sqrt{1+624}}{4}$$

$$= \frac{-1 \pm \sqrt{625}}{4} \text{ volts}$$

As U is positive

$$U = \frac{\sqrt{625}-1}{4} = \frac{24}{4} = 6\text{V}$$

- 2.27 When the disc is in touch with the bottom plate, the entire plate is a equipotential. A charge q' is transferred to the disc.

The electric field on the disc is

$$= \frac{V}{d}$$

$$\therefore q' = -\epsilon_0 \frac{V}{d} \pi r^2$$

The force acting on the disc is

$$-\frac{V}{d} \times q' = \epsilon_0 \frac{V^2}{d^2} \pi r^2$$

If the disc is to be lifted, then

$$\epsilon_0 \frac{V^2}{d^2} \pi r^2 = mg$$

$$\Rightarrow V = \sqrt{\frac{mgd^2}{\pi\epsilon_0 r^2}}$$

2.28
$$U = \frac{1}{4\pi\epsilon_0} \left\{ \frac{q_d q_d}{r} - \frac{q_u q_d}{r} - \frac{q_u q_d}{r} \right\}$$

$$= \frac{9 \times 10^9}{10^{-15}} (1.6 \times 10^{-19})^2 \left\{ (1/3)^2 - (2/3)(1/3) - (2/3)(1/3) \right\}$$

$$= 2.304 \times 10^{-13} \left\{ \frac{1}{9} - \frac{4}{9} \right\} = -7.68 \times 10^{-14} \text{ J}$$

$$= 4.8 \times 10^5 \text{ eV} = 0.48 \text{ MeV} = 5.11 \times 10^{-4} (m_n c^2)$$

- 2.29 Before contact

$$Q_1 = \sigma \cdot 4\pi R^2$$

$$Q_2 = \sigma \cdot 4\pi(2R^2) = 4(\sigma \cdot 4\pi R^2) = 4Q_1$$

After contact :

$$Q_1' + Q_2' = Q_1 + Q_2 = 5Q_1,$$

$$= 5(\sigma \cdot 4\pi R^2)$$

Exemplar Problems–Physics

They will be at equal potentials:

$$\frac{Q_1'}{R} = \frac{Q_2'}{2R}$$

$$\therefore Q_2' = 2Q_1'$$

$$\therefore 3Q_1' = 5(\sigma \cdot 4\pi R^2)$$

$$\therefore Q_1' = \frac{5}{3}(\sigma \cdot 4\pi R^2) \text{ and } Q_2' = \frac{10}{3}(\sigma \cdot 4\pi R^2)$$

$$\therefore \sigma_1 = 5/3 \sigma \text{ and } \therefore \sigma_2 = \frac{5}{6} \sigma$$

2.30 Initially : $V \propto \frac{1}{C}$ and $V_1 + V_2 = E$

$$\Rightarrow V_1 = 3V \text{ and } V_2 = 6V$$

$$\therefore Q_1 = C_1 V_1 = 6C \times 3 = 18 \mu C$$

$$Q_2 = 9 \mu C \text{ and } Q_3 = 0$$

$$\text{Later : } Q_2 = Q_2' + Q_3$$

$$\text{with } C_2 V + C_3 V = Q_2 \Rightarrow V = \frac{Q_2}{C_2 + C_3} = (3/2)V$$

$$Q_2' = (9/2) \mu C \text{ and } Q_3' = (9/2) \mu C$$

2.31 $\sigma = \frac{Q}{\pi R^2}$

$$dU = \frac{1}{4\pi\epsilon_0} \frac{\sigma \cdot 2\pi r dr}{\sqrt{r^2 + z^2}}$$

$$\therefore U = \frac{\pi\sigma}{4\pi\epsilon_0} \int_0^R \frac{2rdr}{\sqrt{r^2 + z^2}}$$

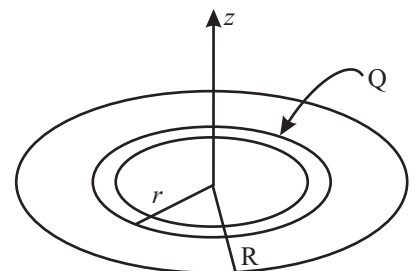
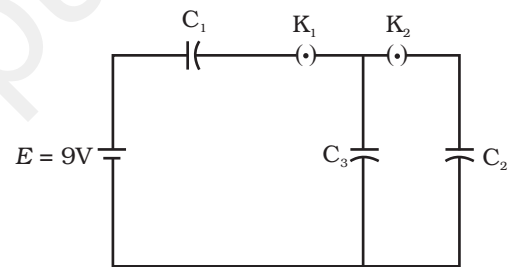

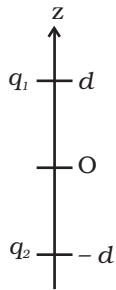

2.32

$$= \frac{2\pi\sigma}{4\pi\epsilon_0} \left[\sqrt{r^2 + z^2} \right]_0^R = \frac{2\pi\sigma}{4\pi\epsilon_0} \left[\sqrt{R^2 + z^2} - z \right]$$

$$= \frac{2Q}{4\pi\epsilon_0 R^2} \left[\sqrt{R^2 + z^2} - z \right]$$

$$\frac{q_1}{\sqrt{x^2 + y^2 + (z-d)^2}} + \frac{q_2}{\sqrt{x^2 + y^2 + (z+d)^2}} = 0$$

$$\therefore \frac{q_1}{\sqrt{x^2 + y^2 + (z-d)^2}} = \frac{-q_2}{\sqrt{x^2 + y^2 + (z+d)^2}}$$

Thus, to have total potential zero, q_1 and q_2 must have opposite signs. Squaring and simplifying, we get.

$$x^2 + y^2 + z^2 + \left[\frac{(q_1/q_2)^2 + 1}{(q_1/q_2)^2 - 1} \right] (2zd) + d^2 = 0$$

This is the equation of a sphere with centre at $\left(0, 0, -2d \left[\frac{q_1^2 + q_2^2}{q_1^2 - q_2^2} \right] \right)$.

Note : if $q_1 = -q_2 \Rightarrow$ Then $z = 0$, which is a plane through mid-point.

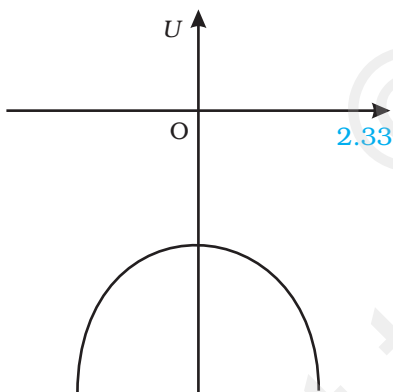

2.33

$$U = \frac{1}{4\pi\epsilon_0} \left\{ \frac{-q^2}{(d-x)} + \frac{-q^2}{(d-x)} \right\}$$

$$U = \frac{-q^2}{4\pi\epsilon_0} \frac{2d}{(d^2 - x^2)}$$

$$\frac{dU}{dx} = \frac{-q^2 \cdot 2d}{4\pi\epsilon_0} \cdot \frac{2x}{(d^2 - x^2)^2}$$

$$U_0 = \frac{2q^2}{4\pi\epsilon_0 d} \quad \frac{dU}{dx} = 0 \text{ at } x = 0$$

$x = 0$ is an equilibrium point.

$$\frac{d^2U}{dx^2} = \left(\frac{-2dq^2}{4\pi\epsilon_0} \right) \left[\frac{2}{(d^2 - x^2)^2} - \frac{8x^2}{(d^2 - x^2)^3} \right]$$

$$= \left(\frac{-2dq^2}{4\pi\epsilon_0} \right) \frac{1}{(d^2 - x^2)^3} [2(d^2 - x^2)^2 - 8x^2]$$

At $x = 0$

$$\frac{d^2U}{dx^2} = \left(\frac{-2dq^2}{4\pi\epsilon_0} \right) \left(\frac{1}{d^6} \right) (2d^2), \text{ which is } < 0.$$

Hence, unstable equilibrium.

Chapter 3

3.1 (b)

3.2 (a)

3.3 (c)

3.4 (b)

3.5 (a)

3.6 (a)

3.7 (b), (d)

3.8 (a), (d)

3.9 (a), (b)

3.10 (b), (c)

3.11 (a), (c)

3.12 When an electron approaches a junction, in addition to the uniform \mathbf{E} that it normally faces (which keep the drift velocity \mathbf{v}_d fixed), there are accumulation of charges on the surface of wires at the junction. These produce electric field. These fields alter direction of momentum.

3.13 Relaxation time is bound to depend on velocities of electrons and ions. Applied electric field affects the velocities of electrons by speeds at the order of 1mm/s, an insignificant effect. Change in T , on the other hand, affects velocities at the order of 10^2 m/s. This can affect τ significantly.

[$\rho = \rho(E, T)$ in which E dependence is ignorable for ordinary applied voltages.]

3.14 The advantage of null point method in a Wheatstone bridge is that the resistance of galvanometer does not affect the balance point and there is no need to determine current in resistances and galvanometer and the internal resistance of a galvanometer. R_{unknown} can be calculated

applying Kirchhoff's rules to the circuit. We would need additional accurate measurement of all the currents in resistances and galvanometer and internal resistance of the galvanometer.

3.15 The metal strips have low resistance and need not be counted in the potentiometer length l_1 of the null point. One measures only their lengths along the straight segments (of lengths 1 meter each). This is easily done with the help of centimeter rulings or meter ruler and leads to accurate measurements.

3.16 Two considerations are required: (i) cost of metal, and (ii) good conductivity of metal. Cost factor inhibits silver. Cu and Al are the next best conductors.

3.17 Alloys have low value of temperature co-efficient (less temperature sensitivity) of resistance and high resistivity.

3.18 Power wasted $P_c = I^2 R_c$
where R_c is the resistance of the connecting wires.

$$P_c = \frac{P^2}{V^2} R_c$$

In order to reduce P_c , power should be transmitted at high voltage.

3.19 If R is increased, the current through the wire will decrease and hence the potential gradient will also decrease, which will result in increase in balance length. So J will shift towards B .

3.20 (i) Positive terminal of E_1 is connected at X and $E_1 > E$.
(ii) Negative terminal of E_1 is connected at X .

3.21

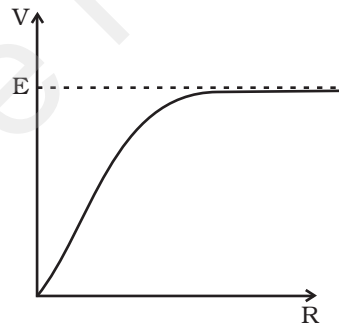

3.22
$$I = \frac{E}{R+nR}; \frac{E}{R+\frac{R}{n}} = 10I$$

$$\frac{1+n}{1+\frac{1}{n}} = 10 = \frac{1+n}{n+1} n = n$$

$$\therefore n = 10.$$

3.23
$$\frac{1}{R_p} = \frac{1}{R_1} + \dots + \frac{1}{R_n}, \quad \frac{R_{\min}}{R_p} = \frac{R_{\min}}{R_1} + \frac{R_{\min}}{R_2} + \dots + \frac{R_{\min}}{R_n} > 1$$

Exemplar Problems–Physics

and $R_s = R_1 + \dots + R_n \geq R_{\max}$.

In Fig. (b), R_{\min} provides an equivalent route as in Fig. (a) for current. But in addition there are $(n-1)$ routes by the remaining $(n-1)$ resistors. Current in Fig.(b) > current in Fig. (a). Effective Resistance in Fig. (b) < R_{\min} . Second circuit evidently affords a greater resistance. You can use Fig. (c) and (d) and prove $R_s > R_{\max}$.

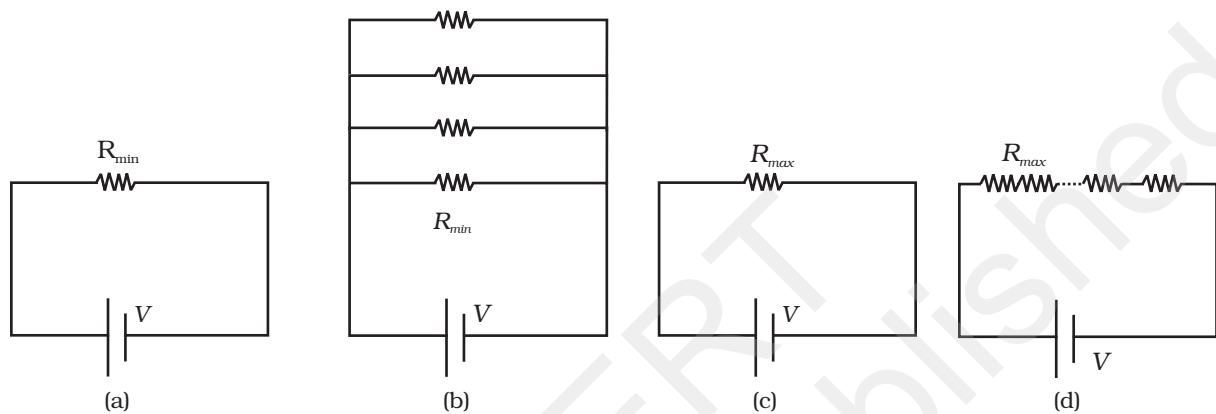

3.24 $I = \frac{6 - 4}{2 + 8} = 0.2A$

P.D. across $E_1 = 6 - 0.2 \times 2 = 5.6 V$

P.D. across $E_2 = V_{AB} = 4 + 0.2 \times 8 = 5.6 V$

Point B is at a higher potential than A

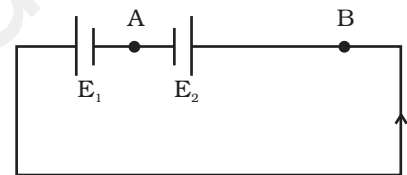

3.25 $I = \frac{E + E}{R + r_1 + r_2}$

$$V_1 = E - Ir_1 = E - \frac{2E}{r_1 + r_2 + R} r_1 = 0$$

$$\text{or } E = \frac{2Er_1}{r_1 + r_2 + R}$$

$$1 = \frac{2r_1}{r_1 + r_2 + R}$$

$$r_1 + r_2 + R = 2r_1$$

$$R = r_1 - r_2$$

3.26 $R_A = \frac{\rho l}{\pi(10^{-3} \times 0.5)^2}$

$$R_B = \frac{\rho l}{\pi[(10^{-3})^2 - (0.5 \times 10^{-3})^2]}$$

$$\frac{R_A}{R_B} = \frac{(10^{-3})^2 - (0.5 \times 10^{-3})^2}{(0.5 \times 10^{-3})^2} = 3 : 1$$

3.27 We can think of reducing entire network to a simple one for any branch R as shown in Fig.

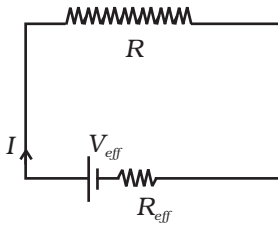

Then current through R is $I = \frac{V_{eff}}{R_{eff} + R}$

Dimensionally $V_{eff} = V_{eff}(V_1, V_2, \dots, V_n)$ has a dimension of voltage and $R_{eff} = R_{eff}(R_1, R_2, \dots, R_m)$ has a dimension of resistance. Therefore if all are increased n -fold

$$V_{eff}^{new} = nV_{eff}, R_{eff}^{new} = nR_{eff}$$

and $R^{new} = nR$.

Current thus remains the same.

3.28 Applying Kirchoff's junction rule:

$$I_1 = I + I_2$$

Kirchoff's loop rule gives:

$$10 = IR + 10I_1 \dots (i)$$

$$2 = 5I_2 - RI = 5(I_1 - I) - RI$$

$$4 = 10I_1 - 10I - 2RI \dots (ii)$$

$$(i) - (ii) \Rightarrow 6 = 3RI + 10I \text{ or, } 2 = I \left(R + \frac{10}{3} \right)$$

$2 = (R + R_{eff})I$ Comparing with $V_{eff} = (R + R_{eff})I$ and $V_{eff} = 2V$

$$R_{eff} = \frac{10}{3} \Omega.$$

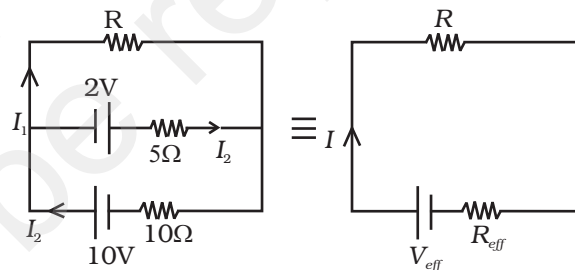

3.29 Power consumption = 2units/hour = 2KW = 2000J/s

$$I = \frac{P}{V} = \frac{2000}{220}; 9 \text{ A}$$

Power loss in wire = RI^2 J/s

$$= \rho \frac{l}{A} I^2 = 1.7 \times 10^{-8} \times \frac{10}{\pi \times 10^{-6}} \times 81 \text{ J/s}$$

$$\square 4 \text{ J/s}$$

$$= 0.2\%$$

$$\text{Power loss in Al wire} = 4 \frac{\rho_{Al}}{\rho_{Cu}} = 1.6 \times 4 = 6.4 \text{ J/s} = 0.32\%$$

3.30 Let R' be the resistance of the potentiometer wire.

$$\frac{10 \times R'}{50 + R'} < 8 \Rightarrow 10R' < 400 + 8R'$$

$$2R' < 400 \text{ or } R' < 200\Omega.$$

$$\frac{10 \times R'}{10 + R'} > 8 \Rightarrow 2R' > 80 \Rightarrow R' > 40$$

$$\frac{10 \times \frac{3}{4}R'}{10 + R'} < 8 \Rightarrow 7.5R' < 80 + 8R'$$

$$R' > 160 \Rightarrow 160 < R' < 200.$$

Any R' between 160Ω and 200Ω will achieve.

Potential drop across 400 cm of wire $> 8V$.

Potential drop across 300 cm of wire $< 8V$.

$$\phi \times 400 > 8V \text{ (}\phi \rightarrow \text{potential gradient)}$$

$$\phi \times 300 < 8V$$

$$\phi > 2V/m$$

$$< 2\frac{2}{3} V/m.$$

3.31 (a) $I = \frac{6}{6} = 1 \text{ A} = nev_d A$

$$v_d = \frac{1}{10^{29} \times 1.6 \times 10^{-19} \times 10^{-6}} = \frac{1}{1.6} \times 10^{-4} \text{ m/s}$$

$$\begin{aligned} K.E &= \frac{1}{2} m_e v_d^2 \times nAl \\ &= \frac{1}{2} \times 9.1 \times 10^{-31} \times \frac{1}{2.56} \times 10^{-8} \times 10^{29} \times 10^{-6} \times 10^{-1}; 2 \times 10^{-17} \text{ J} \end{aligned}$$

(b) Ohmic loss = $RI^2 = 6 \times 1^2 = 6 \text{ J/s}$

All of KE of electrons would be lost in $\frac{2 \times 10^{-17}}{6} \text{ s}; 10^{-17} \text{ s}$

Chapter 4

4.1 (d)

4.2 (a)

4.3 (a)

4.4 (d)

4.5 (a)

4.6 (d)

4.7 (a), (b)

4.8 (b), (d)

4.9 (b), (c)

4.10 (b), (c), (d)

4.11 (a), (b), (d)

4.12 For a charge particle moving perpendicular to the magnetic field:

$$\frac{mv^2}{R} = qvB$$

$$\therefore \frac{qB}{m} = \frac{v}{R} = \omega$$

$$\therefore [\omega] = \left[\frac{qB}{m} \right] = \left[\frac{v}{R} \right] = [T]^{-1}.$$

4.13 $dW = \mathbf{F} \cdot d\mathbf{l} = 0$

$$\Rightarrow \mathbf{F} \cdot \mathbf{v} dt = 0$$

$$\Rightarrow \mathbf{F} \cdot \mathbf{v} = 0$$

\mathbf{F} must be velocity dependent which implies that angle between \mathbf{F} and \mathbf{v} is 90° . If \mathbf{v} changes (direction) then (directions) \mathbf{F} should also change so that above condition is satisfied.

4.14 Magnetic force is frame dependent. Net acceleration arising from this is however frame independent (non-relativistic physics) for inertial frames.

4.15 Particle will accelerate and decelerate alternatively. So the radius of path in the Dees will remain unchanged.

4.16 At O_2 , the magnetic field due to I_1 is along the y -axis. The second wire is along the y -axis and hence the force is zero.

4.17 $\mathbf{B} = \frac{1}{4}(\hat{\mathbf{i}} + \hat{\mathbf{j}} + \hat{\mathbf{k}}) \frac{\mu_0 I}{2R}$

4.18 No dimensionless quantity $[T]^{-1} = [\omega] = \left[\frac{eB}{m} \right]$

4.19 $\mathbf{E} = E_0 \hat{\mathbf{i}}, E_0 > 0, \mathbf{B} = B_0 \hat{\mathbf{k}}$

4.20 Force due to $d\mathbf{l}_2$ on $d\mathbf{l}_1$ is zero.

Force due to $d\mathbf{l}_1$ on $d\mathbf{l}_2$ is non-zero.

Exemplar Problems–Physics

4.21 $i_G (G + R_1) = 2$ for 2V range

$$i_G (G + R_1 + R_2) = 20 \text{ for 20V range}$$

$$\text{and } i_G (G + R_1 + R_2 + R_3) = 200 \text{ for 200V range}$$

Gives $R_1 = 1990\Omega$
 $R_2 = 18 \text{ k}\Omega$
 and $R_3 = 180 \text{ k}\Omega$

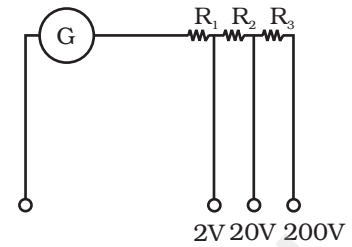

4.22 $F = BIl \sin \theta = BIl$

$$B = \frac{\mu_0 I}{2\pi h}$$

$$F = mg = \frac{\mu_0 I^2 l}{2\pi h}$$

$$h = \frac{\mu_0 I^2 l}{2\pi mg} = \frac{4\pi \times 10^{-7} \times 250 \times 25 \times 1}{2\pi \times 2.5 \times 10^{-3} \times 9.8}$$

$$= 51 \times 10^{-4}$$

$$h = 0.51 \text{ cm}$$

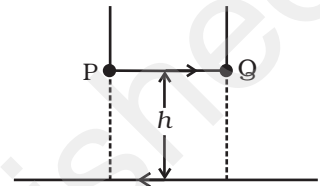

4.23 When the field is off $\sum \tau = 0$

$$Mgl = W_{\text{coil}} l$$

$$500 \text{ g } l = W_{\text{coil}} l$$

$$W_{\text{coil}} = 500 \times 9.8 \text{ N}$$

When the magnetic field is switched on

$$Mgl + mgl = W_{\text{coil}} l + IBL \sin 90^\circ l$$

$$mgl = BIL l$$

$$m = \frac{BIL}{g} = \frac{0.2 \times 4.9 \times 1 \times 10^{-2}}{9.8} = 10^{-3} \text{ kg}$$

$$= 1 \text{ g}$$

4.24 $F_1 = i_1 l B = \frac{V_0 l B}{R}$ $\tau_1 = \frac{d}{2\sqrt{2}} F_1 = \frac{V_0 l d B}{2\sqrt{2} R}$

$$F_2 = i_2 l B = \frac{V_0 l B}{2R}$$

$$\tau_2 = \frac{d}{2\sqrt{2}} F_2 = \frac{V_0 l d B}{4\sqrt{2} R}$$

Net torque $\tau = \tau_1 - \tau_2$

$$\tau = \frac{1}{4\sqrt{2}} \frac{V_0 A B}{R}$$

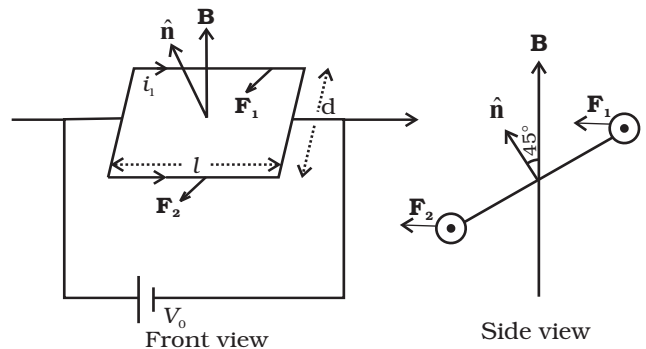

4.25 As \mathbf{B} is along the x axis, for a circular orbit the momenta of the two particles are in the $y - z$ plane. Let \mathbf{p}_1 and \mathbf{p}_2 be the momentum of the electron and positron, respectively. Both of them define a circle of radius R . They shall define circles of opposite sense. Let \mathbf{p}_1 make an angle θ with the y axis \mathbf{p}_2 must make the same angle. The centres of the respective circles must be perpendicular to the momenta and at a distance R . Let the center of the electron be at C_e and of the positron at C_p . The coordinates of C_e is

The coordinates of C_e is

$$C_e \equiv (0, -R \sin \theta, R \cos \theta)$$

The coordinates of C_p is

$$C_p \equiv (0, -R \sin \theta, \frac{3}{2} R - R \cos \theta)$$

The circles of the two shall not overlap if the distance between the two centers are greater than $2R$.

Let d be the distance between C_p and C_e .

$$\text{Then } d^2 = (2R \sin \theta)^2 + \left(\frac{3}{2} R - 2R \cos \theta \right)^2$$

$$= 4R^2 \sin^2 \theta + \frac{9}{4} R^2 - 6R^2 \cos \theta + 4R^2 \cos^2 \theta$$

$$= 4R^2 + \frac{9}{4} R^2 - 6R^2 \cos \theta$$

Since d has to be greater than $2R$

$$d^2 > 4R^2$$

$$\Rightarrow 4R^2 + \frac{9}{4} R^2 - 6R^2 \cos \theta > 4R^2$$

$$\Rightarrow \frac{9}{4} > 6 \cos \theta$$

$$\text{Or, } \cos \theta < \frac{3}{8}$$

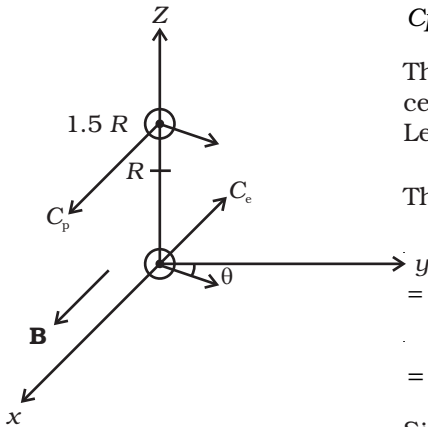

4.26

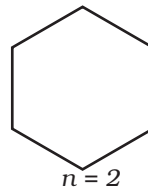
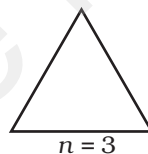

Area: $A = \frac{\sqrt{3}}{4} a^2$

$A = a^2$

$A = \frac{3\sqrt{3}}{4} a^2$

Current I is same for all

Magnetic moment $m = n I A$

$$\therefore m = I a^2 \sqrt{3}$$

$$3a^2 I$$

$$3\sqrt{3} a^2 I$$

(Note: m is in a geometric series)

4.27

(a) $B(z)$ points in the same direction on z -axis and hence $J(L)$ is a monotonically increasing function of L .

(b) $J(L)$ + Contribution from large distance on contour $C = \mu_0 I$

$$\therefore \text{as } L \rightarrow \infty$$

Contribution from large distance $\rightarrow 0$ (as $B \propto 1/r^3$)

$$J(\infty) = \mu_0 I$$

Exemplar Problems–Physics

$$(c) B_z = \frac{\mu_0 I R^2}{2(z^2 + R^2)^{3/2}}$$

$$\int_{-\infty}^{\infty} B_z dz = \int_{-\infty}^{\infty} \frac{\mu_0 I R^2}{2(z^2 + R^2)^{3/2}} dz$$

$$\text{Put } z = R \tan \theta \quad dz = R \sec^2 \theta d\theta$$

$$\therefore \int_{-\infty}^{\infty} B_z dz = \frac{\mu_0 I}{2} \int_{-\pi/2}^{\pi/2} \cos \theta d\theta = \mu_0 I$$

$$(d) B(z)_{\text{square}} < B(z)_{\text{circular coil}}$$

$$\therefore \mathcal{J}(L)_{\text{square}} < \mathcal{J}(L)_{\text{circular coil}}$$

But by using arguments as in (b)

$$\mathcal{J}(\infty)_{\text{square}} = \mathcal{J}(\infty)_{\text{circular}}$$

- 4.28** $i_G \cdot G = (i_1 - i_G) (S_1 + S_2 + S_3)$ for $i_1 = 10\text{mA}$
 $i_G (G + S_1) = (i_2 - i_G) (S_2 + S_3)$ for $i_2 = 100\text{mA}$
 and $i_G (G + S_1 + S_2) = (i_3 - i_G) (S_3)$ for $i_3 = 1\text{A}$
 gives $S_1 = 1\text{W}$, $S_2 = 0.1\text{W}$ and $S_3 = 0.01\text{W}$

- 4.29** (a) zero

(b) $\frac{\mu_0 i}{2\pi R}$ perpendicular to AO towards left.

(c) $\frac{\mu_0 i}{\pi R}$ perpendicular to AO towards left.

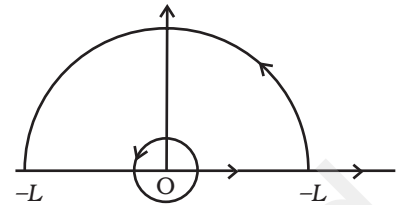

Chapter 5

- 5.1** (c)

- 5.2** (a)

- 5.3** (c)

- 5.4** (b)

- 5.5** (b)

- 5.6** (a), (d)

- 5.7** (a), (d)

- 5.8** (a), (d)

- 5.9** (a), (c), (d)

- 5.10** (b), (c), (d)

5.11 $\mu_p \approx \frac{eh}{2m_p}$ and $\mu_e \approx \frac{eh}{2m_e}$, $\hbar = \frac{h}{2\pi}$

$$\mu_e \gg \mu_p \text{ because } m_p \gg m_e.$$

5.12 $Bl = \mu_0 Ml = \mu_0(I + I_M)$ and $H = 0 = I$

$Ml = I_M = 10^6 \times 0.1 = 10^5 \text{ A}$.

5.13 $x \propto \text{density } \rho$. Now $\frac{\rho_N}{\rho_{Cu}} = \frac{28\text{g}/22.4\text{Lt}}{8\text{g/cc}} = \frac{3.5}{22.4} \times 10^{-3} = 1.6 \times 10^{-4}$.

$\frac{x_N}{x_{Cu}} = 5 \times 10^{-4}$ (from given data).

Hence major difference is accounted for by density.

5.14 Diamagnetism is due to orbital motion of electrons developing magnetic moments opposite to applied field and hence is not much affected by temperature.

Paramagnetism and ferromagnetism is due to alignments of atomic magnetic moments in the direction of the applied field. As temperature increases, this alignment is disturbed and hence susceptibilities of both decrease as temperature increases.

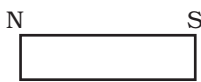

5.15 (i) Away from the magnet.

(ii) Magnetic moment is from left to right

5.16 $\mathbf{B} = \frac{\mu_0}{4\pi} \frac{3\mathbf{m}\cdot\hat{\mathbf{r}}}{r^3}, m = m\hat{\mathbf{k}}$

$d\mathbf{s} = \hat{\mathbf{r}} r^2 \sin\theta d\theta d\phi$

$0 \leq \theta \leq \pi, 0 \leq \phi \leq 2\pi$

$\oint \mathbf{B} \cdot d\mathbf{s} = \frac{\mu_0 m}{4\pi} \int \frac{3 \cos\theta}{r^3} r^2 \sin\theta d\theta d\phi$
 $= 0$ [due to θ integral].

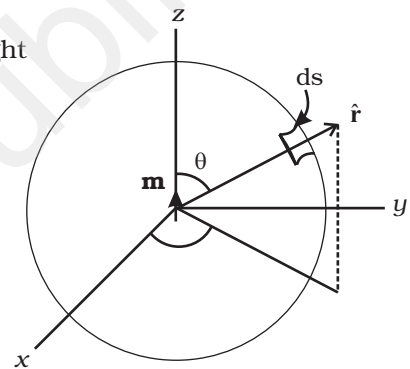

5.17 Net $m = 0$. Only possibility is shown in Fig.

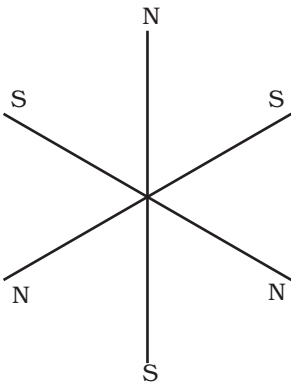

5.18 $E(r) = c B(r), P = \frac{m}{c}$. Mass and moment of inertia of dipoles are equal.

5.19 $T = 2\pi \sqrt{\frac{I}{mB}} \quad I' = \frac{1}{2} \times \frac{1}{4} I$ and $m' = \frac{m}{2} \quad T' = \frac{1}{2} T$

5.20 Consider a line of \mathbf{B} through the bar magnet. It must be closed. Let C be the amperian loop.

$\int_Q^P \mathbf{H} \cdot d\mathbf{l} = \int_Q^P \frac{\mathbf{B}}{\mu_0} \cdot d\mathbf{l} > 0$

$\oint_{PQP} \mathbf{H} \cdot d\mathbf{l} = 0$

$$\int_P^Q \mathbf{H} \cdot d\mathbf{l} < 0$$

$P \rightarrow Q$ is inside the bar.

Hence \mathbf{H} is making an obtuse angle with $d\mathbf{l}$.

5.21 (i) Along z axis

$$\mathbf{B} = \frac{\mu_0}{4\pi} \frac{2\mathbf{m}}{r^3}$$

$$\int_a^R \mathbf{B} \cdot d\mathbf{l} = \frac{\mu_0}{4\pi} 2m \int_a^R \frac{dz}{z^3} = \frac{\mu_0 m}{2\pi} \left(-\frac{1}{2}\right) \left(\frac{1}{R^2} - \frac{1}{a^2}\right)$$

(ii) Along the quarter circle of radius R

$$B_\theta = \frac{\mu_0}{4\pi} \frac{-\mathbf{m} \cdot \hat{\boldsymbol{\theta}}}{R^3} = \frac{-\mu_0}{4\pi} \frac{m}{R^3} (-\sin\theta)$$

$$\mathbf{B} \cdot d\mathbf{l} = \frac{\mu_0 m}{4\pi R^2} \sin\theta d$$

$$\int_0^{\frac{\pi}{2}} \mathbf{B} \cdot d\mathbf{l} = \frac{\mu_0 m}{4\pi R^2}$$

(iii) Along x -axis

$$\mathbf{B} = \frac{\mu_0}{4\pi} \left(\frac{-m}{x^3}\right)$$

$$\int \mathbf{B} \cdot d\mathbf{l} = 0$$

(iv) Along the quarter circle of radius a

$$\mathbf{B} \cdot d\mathbf{l} = \frac{-\mu_0 m}{4\pi a^2} \sin\theta d\theta, \quad \int \mathbf{B} \cdot d\mathbf{l} = -\frac{\mu_0 m}{4\pi a^2} \int_0^{\frac{\pi}{2}} \sin\theta d\theta = \frac{-\mu_0 m}{4\pi a^2}$$

$$\text{Add } \oint_C \mathbf{B} \cdot d\mathbf{l} = 0$$

5.22 χ is dimensionless.

χ depends on magnetic moment induced when H is turned on. H couples to atomic electrons through its charge e . The effect on m is via current I which involves another factor of ' e '. The combination " $\mu_0 e^2$ " does not depend on the "charge" Q dimension.

$$\chi = \mu_0 e^2 m^\alpha v^\beta R^\gamma$$

$$\mu_0 c^2 = \frac{1}{c^2} \frac{e^2}{\epsilon_0} \sim \frac{1}{c^2} \frac{e^2}{\epsilon_0 R} \cdot R \sim \frac{\text{Energy length}}{c^2}$$

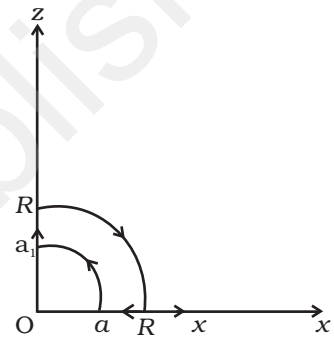
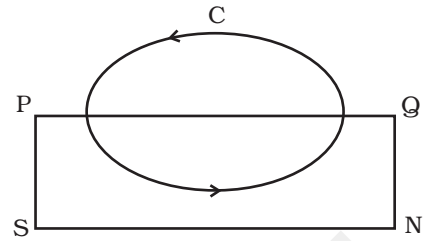

$$[\chi] = M^0 L^0 T^0 Q^0 = \frac{ML^3 T^{-2}}{L^2 T^{-2}} M^\alpha \left(\frac{L}{T}\right)^\beta L^\gamma Q^0$$

$$\alpha = -1, \beta = 0, \gamma = -1$$

$$\chi = \frac{\mu_0 e^2}{mR} \sim \frac{10^{-6} \times 10^{-38}}{10^{-30} \times 10^{-10}} \sim 10^{-4}$$

5.23 (i) $|\mathbf{B}| = \frac{\mu_0 m}{4\pi R^3} (4 \cos^2 \theta + \sin^2 \theta)^{1/2}$

$$\frac{|\mathbf{B}|^2}{\left(\frac{\mu_0}{4\pi R^3}\right)^2 m^2} = 3 \cos^2 \theta + 1, \text{ minimum at } \theta = \frac{\pi}{2}$$

$|\mathbf{B}|$ is minimum at magnetic equator.

(ii) $\tan(\text{dip angle}) = \frac{B_V}{B_H} = 2 \cot \theta$

at $\theta = \frac{\pi}{2}$ dip angle vanishes. Magnetic equator is again the locus.

(iii) Dip angle is $\pm 45^\circ$ when $\left|\frac{B_V}{B_H}\right| = 1$

$$2 \cot \theta = 1$$

$$\theta = \tan^{-1} 2 \text{ is the locus.}$$

5.24 Refer to the adjacent Fig.

1. P is in S (needle will point both north)

Declination = 0

P is also on magnetic equator.

$$\therefore \text{dip} = 0$$

2. Q is on magnetic equator.

$$\therefore \text{dip} = 0$$

but declination = 11.3° .

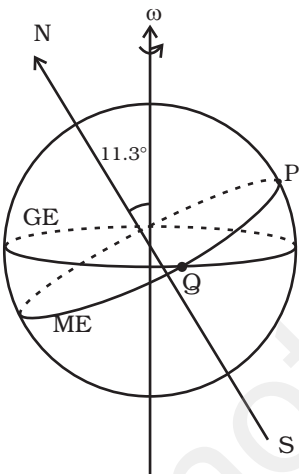

5.25 $n_1 = \frac{L}{2\pi R}$

$$n_2 = \frac{L}{4a}$$

$$m_1 = n_1 I A_1$$

$$m_2 = n_2 I A_2$$

$$= \frac{L}{2\pi R} I\pi R \qquad = \frac{L}{4a} Ia^2 = \frac{L}{4} It$$

$$I_1 = \frac{MR^2}{2} \text{ (moment of inertia about an axis through the diameter)}$$

$$I_2 = \frac{Ma^2}{12}$$

$$\omega_1^2 = \frac{m_1 B}{I_1} \qquad \omega_2^2 = \frac{m_2 B}{I_2}$$

$$\frac{m_1}{I_1} = \frac{m_2}{I_2}$$

$$\frac{LR}{2\pi} \times \frac{I}{MR^2} = \frac{\frac{L}{4} Ia}{\frac{Ma^2}{12}} \Rightarrow a = \frac{3\pi}{4} R.$$

Chapter 6

- 6.1 (c)
 6.2 (b)
 6.3 (a)
 6.4 (d)
 6.5 (a)
 6.6 (b)
 6.7 (a), (b), (d)
 6.8 (a), (b), (c)
 6.9 (a), (d)
 6.10 (b), (c)
 6.11 No part of the wire is moving and so motional e.m.f. is zero. The magnet is stationary and hence the magnetic field does not change with time. This means no electromotive force is produced and hence no current will flow in the circuit.
 6.12 The current will increase. As the wires are pulled apart the flux will leak through the gaps. Lenz's law demands that induced e.m.f. resist this decrease, which can be done by an increase in current.

- 6.13** The current will decrease. As the iron core is inserted in the solenoid, the magnetic field increases and the flux increases. Lenz's law implies that induced e.m.f. should resist this increase, which can be achieved by a decrease in current.
- 6.14** No flux was passing through the metal ring initially. When the current is switched on, flux passes through the ring. According to Lenz's law this increase will be resisted and this can happen if the ring moves away from the solenoid. One can analyse this in more detail (Fig 6.5). If the current in the solenoid is as shown, the flux (downward) increases and this will cause a counterclockwise current (as seen from the top in the ring). As the flow of current is in the opposite direction to that in the solenoid, they will repel each other and the ring will move upward.
- 6.15** When the current in the solenoid decreases a current flows in the metal ring as in the solenoid. Thus there will be a downward force. This means the ring will remain on the cardboard. The upward reaction of the cardboard on the ring will increase.
- 6.16** For the magnet, eddy currents are produced in the metallic pipe. These currents will oppose the motion of the magnet. Therefore magnet's downward acceleration will be less than the acceleration due to gravity g . On the other hand, an unmagnetised iron bar will not produce eddy currents and will fall with an acceleration g . Thus the magnet will take more time.

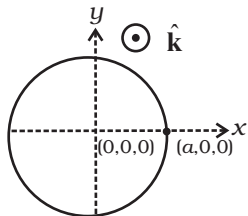

- 6.17** Flux through the ring

$$\phi = B_o(\pi a^2) \cos \omega t$$

$$\varepsilon = B(\pi a^2)\omega \sin \omega t$$

$$I = B(\pi a^2)\omega \sin \omega t / R$$

Current at

$$t = \frac{\pi}{2\omega}; I = \frac{B(\pi a^2)\omega}{R} \text{ along } \hat{j}$$

$$t = \frac{\pi}{\omega}; I = 0$$

$$t = \frac{3\pi}{2\omega}; I = \frac{B(\pi a^2)\omega}{R} \text{ along } -\hat{j}$$

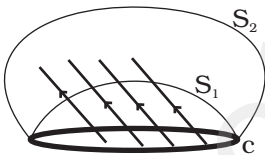

- 6.18** One gets the same answer for flux. Flux can be thought of as the number of magnetic field lines passing through the surface (we draw $dN = B \Delta A$ lines in an area $\Delta A \perp$ to \mathbf{B}). As lines of \mathbf{B} cannot end or start in space (they form closed loops) number of lines passing through surface S_1 must be the same as the number of lines passing through the surface S_2 .

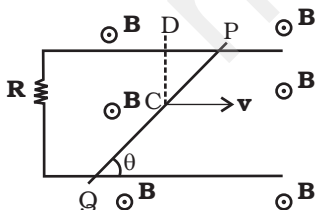

- 6.19** Motional electric field E along the dotted line CD (\perp to both \mathbf{v} and \mathbf{B} and along $\mathbf{v} \times \mathbf{B}$) = vB

Exemplar Problems–Physics

$$\begin{aligned} \text{E.M.F. along PQ} &= (\text{length PQ}) \times (\text{Field along PQ}) \\ &= \frac{d}{\cos \theta} \times vB \cos \theta = dvB. \end{aligned}$$

Therefore,

$$I = \frac{dvB}{R} \text{ and is independent of } q.$$

- 6.20** Maximum rate of change of current is in AB. So maximum back emf will be obtained between $5\text{s} < t < 10\text{s}$.

$$\text{If } u = L \frac{1}{5} \left(\text{for } t = 3\text{s}, \frac{dI}{dt} = 1/5 \right) \quad (L \text{ is a constant})$$

$$\text{For } 5\text{s} < t < 10\text{s} \quad u_1 = -L \frac{3}{5} = -\frac{3}{5}L = -3e$$

Thus at $t = 7\text{s}$, $u_1 = -3e$.

For $10\text{s} < t < 30\text{s}$

$$u_2 = L \frac{2}{20} = \frac{L}{10} = \frac{1}{2}e$$

For $t > 30\text{s}$ $u_2 = 0$

- 6.21** Mutual inductance $= \frac{10^{-2}}{2} = 5\text{mH}$

$$\text{Flux} = 5 \times 10^{-3} \times 1 = 5 \times 10^{-3} \text{Wb.}$$

- 6.22** Let us assume that the parallel wires are at $y = 0$ and $y = d$. At $t = 0$, AB has $x = 0$ and moves with a velocity $v\hat{i}$.

At time t , wire is at $x(t) = vt$.

$$\text{Motional e.m.f.} = (B_o \sin \omega t) vd(-\hat{j})$$

E.m.f due to change in field (along OBAC)

$$= -B_o \omega \cos \omega t x(t)d$$

$$\text{Total e.m.f} = -B_o d [\omega x \cos(\omega t) + v \sin(\omega t)]$$

$$\text{Along OBAC, Current (clockwise)} = \frac{B_o d}{R} (\omega x \cos \omega t + v \sin \omega t)$$

$$\text{Force needed along } \hat{i} = \frac{B_o d}{R} (\omega x \cos \omega t + v \sin \omega t) \times d \times B_o \sin \omega t$$

$$= \frac{B_o^2 d^2}{R} (\omega x \cos \omega t + v \sin \omega t) \sin \omega t.$$

- 6.23** (i) Let the wire be at $x = x(t)$ at time t .

$$\text{Flux} = B(t) l x(t)$$

$$E = -\frac{d\phi}{dt} = -\frac{dB(t)}{dt} l x(t) - B(t) l v(t) \quad (\text{second term due to motional emf})$$

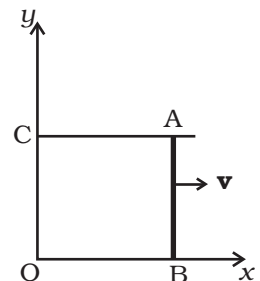

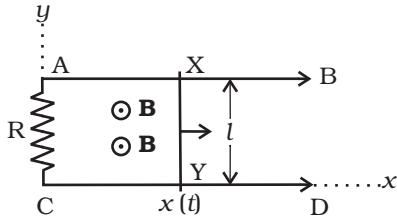

$$I = \frac{1}{R} E$$

$$\text{Force} = \frac{lB(t)}{R} \left[-\frac{dB}{dt} l x(t) - B(t) l v(t) \right] \hat{i}$$

$$m \frac{d^2 x}{dt^2} = -\frac{l^2 B}{R} \frac{dB}{dt} x(t) - \frac{l^2 B^2}{R} \frac{dx}{dt}$$

$$(ii) \quad \frac{dB}{dt} = 0, \quad \frac{d^2 x}{dt^2} + \frac{l^2 B^2}{mR} \frac{dx}{dt} = 0$$

$$\frac{dv}{dt} + \frac{l^2 B^2}{mR} v = 0$$

$$v = A \exp\left(\frac{-l^2 B^2 t}{mR}\right)$$

At $t = 0$, $v = u$

$$v(t) = u \exp(-l^2 B^2 t / mR).$$

$$(iii) \quad I^2 R = \frac{B^2 l^2 v^2(t)}{R^2} \times R = \frac{B^2 l^2}{R} u^2 \exp(-2l^2 B^2 t / mR)$$

$$\text{Power lost} = \int_0^t I^2 R dt = \frac{B^2 l^2}{R} u^2 \frac{mR}{2l^2 B^2} [1 - e^{-(l^2 B^2 t / mR)}]$$

$$= \frac{m}{2} u^2 - \frac{m}{2} v^2(t)$$

= decrease in kinetic energy.

6.24 Between time $t = 0$ and $t = \frac{\pi}{4\omega}$, the rod OP will make contact with the side BD. Let the length OQ of the contact at some time t such that

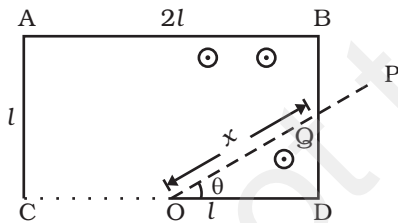

$$0 < t < \frac{\pi}{4\omega}$$

be x . The flux through the area ODQ is

$$\phi = B \frac{1}{2} QD \times OD = B \frac{1}{2} l \tan \theta \times l$$

$$= \frac{1}{2} B l^2 \tan \theta \text{ where } \theta = \omega t$$

Thus the magnitude of the emf generated is $\varepsilon = \frac{d\phi}{dt} = \frac{1}{2} B l^2 \omega \sec^2 \omega t$

The current is $I = \frac{\varepsilon}{R}$ where R is the resistance of the rod in contact.

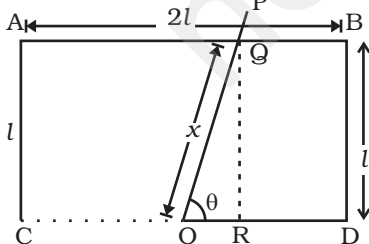

Exemplar Problems–Physics

$$R = \lambda x = \frac{\lambda l}{\cos \omega t}$$

$$\therefore I = \frac{1}{2} \frac{Bl^2 \omega}{\lambda l} \sec^2 \omega t \cos \omega t = \frac{Bl\omega}{2\lambda \cos \omega t}$$

For $\frac{\pi}{4\omega} < t < \frac{3\pi}{\omega}$ the rod is in contact with the side AB. Let the length of the rod in contact (OQ) be x . The

flux through OQBD is $\phi = \left(l^2 + \frac{1}{2} \frac{l^2}{\tan \theta} \right) B$ where $\theta = \omega t$

Thus the magnitude of emf generated is

$$\varepsilon = \frac{d\phi}{dt} = \frac{1}{2} Bl^2 \omega \frac{\sec^2 \omega t}{\tan^2 \omega t}$$

The current is $I = \frac{\varepsilon}{R} = \frac{\varepsilon}{\lambda x} = \frac{\varepsilon \sin \omega t}{\lambda l} = \frac{1}{2} \frac{Bl\omega}{\lambda \sin \omega t}$

For $\frac{3\pi}{\omega} < t < \frac{\pi}{\omega}$ the rod will be in touch with OC. The Flux through

$$OQABD \text{ is } \phi = \left(2l^2 - \frac{l^2}{2 \tan \omega t} \right) B$$

Thus the magnitude of emf

$$\varepsilon = \frac{d\phi}{dt} = \frac{Bl^2 \omega \sec^2 \omega t}{2 \tan^2 \omega t}$$

$$I = \frac{\varepsilon}{R} = \frac{\varepsilon}{\lambda x} = \frac{1}{2} \frac{Bl\omega}{\lambda \sin \omega t}$$

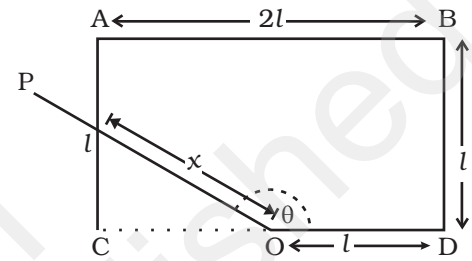

6.25 At a distance r from the wire,

$$\text{Field } B(r) = \frac{\mu_0 I}{2\pi r} \text{ (out of paper).}$$

Total flux through the loop is

$$\text{Flux} = \frac{\mu_0 I}{2\pi} l \int_{x_0}^x \frac{dr}{r} = \frac{\mu_0 I}{2\pi} l \ln \frac{x}{x_0}$$

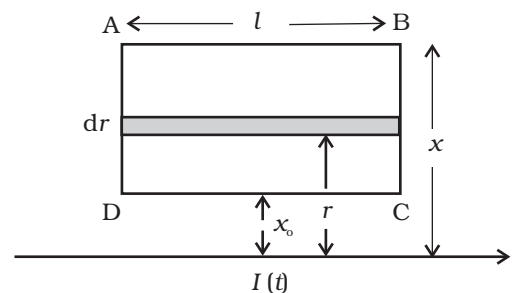

$$\frac{1}{R} \frac{dI}{dt} = \frac{\varepsilon}{R} = I = \frac{\mu_0 I \lambda}{2\pi R} \ln \frac{x}{x_0}$$

6.26 If $I(t)$ is the current in the loop.

$$I(t) = \frac{1}{R} \frac{d\phi}{dt}$$

If Q is the charge that passed in time t ,

$$I(t) = \frac{dQ}{dt} \text{ or } \frac{dQ}{dt} = \frac{1}{R} \frac{d\phi}{dt}$$

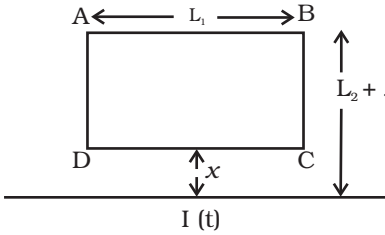

$$\text{Integrating } Q(t_1) - Q(t_2) = \frac{1}{R} [\phi(t_1) - \phi(t_2)]$$

$$\phi(t_1) = L_1 \frac{\mu_0}{2\pi} \int_x^{L_2+x} \frac{dx'}{x'} I(t_1)$$

$$= \frac{\mu_0 L_1}{2\pi} I(t_1) \ln \frac{L_2 + x}{x}$$

The magnitude of charge is

$$Q = \frac{\mu_0 L_1}{2\pi} \ln \frac{L_2 + x}{x} [I_0 - 0]$$

$$= \frac{\mu_0 L_1 I_0}{2\pi} \ln \left(\frac{L_2 + x}{x} \right)$$

6.27 $2\pi bE = E.M.F = \frac{B \cdot \pi a^2}{\Delta t}$ where E is the electric field generated around the ring.

$$\text{Torque} = b \times \text{Force} = Q E b = Q \left[\frac{B \pi a^2}{2\pi b \Delta t} \right] b$$

$$= Q \frac{B a^2}{2 \Delta t}$$

If ΔL is the change in angular momentum

$$\Delta L = \text{Torque} \times \Delta t = Q \frac{B a^2}{2}$$

Exemplar Problems–Physics

Initial angular momentum = 0

$$\text{Final angular momentum} = mb^2\omega = \frac{QBa^2}{2}$$

$$\omega = \frac{QBa^2}{2mb^2}$$

6.28 $m \frac{d^2x}{dt^2} = mg \sin \theta - \frac{B \cos \theta d}{R} \left(\frac{dx}{dt} \right) \times (Bd) \cos \theta$

$$\frac{dv}{dt} = g \sin \theta - \frac{B^2 d^2}{mR} (\cos \theta)^2 v$$

$$\frac{dv}{dt} + \frac{B^2 d^2}{mR} (\cos \theta)^2 v = g \sin \theta$$

$$v = \left(\frac{g \sin \theta}{\frac{B^2 d^2 \cos^2 \theta}{mR}} \right) + A \exp \left(-\frac{B^2 d^2}{mR} (\cos^2 \theta) t \right) \quad (\text{A is a constant to be}$$

determine by initial conditions)

$$= \frac{mgR \sin \theta}{B^2 d^2 \cos^2 \theta} \left(1 - \exp \left(-\frac{B^2 d^2}{mR} (\cos^2 \theta) t \right) \right)$$

6.29 If $Q(t)$ is charge on the capacitor (note current flows from A to B)

$$I = \frac{vBd}{R} - \frac{Q}{RC}$$

$$\Rightarrow \frac{Q}{RC} + \frac{dQ}{dt} = \frac{vBd}{R}$$

$$Q = vBdC + Ae^{-t/RC}$$

$$\therefore \Rightarrow Q = vBdC[1 - e^{-t/RC}]$$

(At time $t = 0$, $Q = 0 = A = -vBdC$). Differentiating, we get

$$I = \frac{vBd}{R} e^{-t/RC}$$

6.30 $-L \frac{dI}{dt} + vBd = IR$

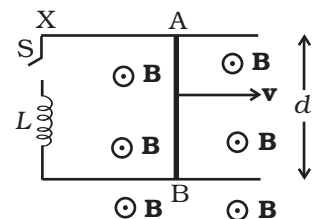
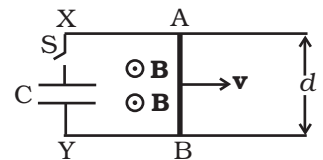

$$L \frac{dI}{dt} + IR = vBd$$

$$I = \frac{vBd}{R} + A e^{-Rt/L}$$

At $t = 0$ $I = 0 \Rightarrow A = -\frac{vBd}{R}$

$$I = \frac{vBd}{R} (1 - e^{-Rt/L}).$$

6.31 $\frac{d\phi}{dt}$ = rate of change in flux = $(\pi l^2) B_0 l \frac{dz}{dt} = IR.$

$$I = \frac{\pi l^2 B_0 \lambda v}{R}$$

Energy lost/second = $I^2 R = \frac{(\pi l^2 \lambda)^2 B_0^2 v^2}{R}$

This must come from rate of change in PE = $m g \frac{dz}{dt} = mgv$

(as kinetic energy is constant for $v = \text{constant}$)

Thus, $mgv = \frac{(\pi l^2 \lambda B_0)^2 v^2}{R}$

Or, $v = \frac{mgR}{(\pi l^2 \lambda B_0)^2}$

6.32 Magnetic field due to a solnoid S, $B = \mu_0 nI$

Magnetic flux in smaller coil $\phi = NBA$ where $A = \pi b^2$

So $e = \frac{-d\phi}{dt} = \frac{-d}{dt}(NBA)$

$$= -N\pi b^2 \frac{d(B)}{dt} = -N\pi b^2 \frac{d}{dt}(\mu_0 nI)$$

$$= -N\pi b^2 \mu_0 n \frac{dI}{dt}$$

$$= -Nn\pi\mu_0 b^2 \frac{d}{dt}(mt^2 + C) = -\mu_0 Nn\pi b^2 2mt$$

$$e = -\mu_0 Nn\pi b^2 2mt$$

Negative sign signifies opposite nature of induced emf. The magnitude of emf varies with time as shown in the Fig.

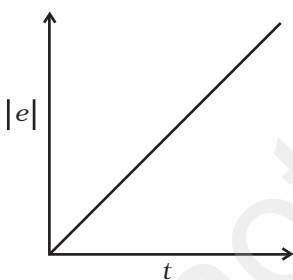

Chapter 7

- 7.1 (b)
 7.2 (c)
 7.3 (c)
 7.4 (b)
 7.5 (c)
 7.6 (c)
 7.7 (a)
 7.8 (a), (d)
 7.9 (c), (d)
 7.10 (a), (b), (d)
 7.11 (a), (b), (c)
 7.12 (c), (d)
 7.13 (a), (d)
 7.14 Magnetic energy analogous to kinetic energy and electrical energy analogous to potential energy.
 7.15 At high frequencies, capacitor \approx short circuit (low reactance) and inductor \approx open circuit (high reactance). Therefore, the equivalent circuit $Z \approx R_1 + R_3$ as shown in the Fig.

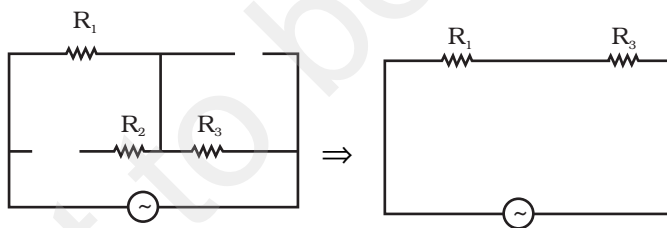

- 7.16 (a) Yes, if rms voltage in the two circuits are same then at resonance, the rms current in *LCR* will be same as that in *R* circuit.
 (d) No, because $R \leq Z$, so $I_a \geq I_b$.
 7.17 Yes, No.
 7.18 Bandwidth corresponds to frequencies at which $I_m = \frac{1}{\sqrt{2}} I_{max}$
 $\approx 0.7 I_{max}$.

It is shown in the Fig.

$$\Delta\omega = 1.2 - 0.8 = 0.4 \text{ rad/s}$$

7.19 $I_{\text{rms}} = 1.6\text{A}$ (shown in Fig. by dotted line)

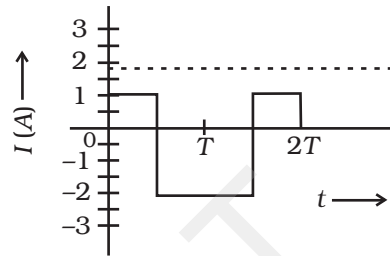
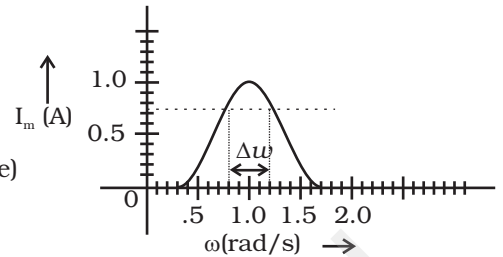

7.20 From negative to zero to positive; zero at resonant frequency.

7.21 (a) A

(b) Zero

(c) L or C or LC

7.22 An a.c current changes direction with the source frequency and the attractive force would average to zero. Thus, the a.c ampere must be defined in terms of some property that is independent of the direction of current. Joule's heating effect is such property and hence it is used to define rms value of a.c.

7.23 $X_L = \omega L = 2\pi fL$

$$= 3.14\Omega$$

$$Z = \sqrt{R^2 + L^2}$$

$$= \sqrt{(3.14)^2 + (1)^2} = \sqrt{10.86}$$

$$; 3.3\Omega$$

$$\tan \phi = \frac{\omega L}{R} = 3.14$$

$$\phi = \tan^{-1}(3.14)$$

$$; 72^\circ$$

$$; \frac{72 \times \pi}{180} \text{ rad.}$$

$$\text{Timelag } \Delta t = \frac{\phi}{\omega} = \frac{72 \times \pi}{180 \times 2\pi \times 50} = \frac{1}{250} \text{ s}$$

Exemplar Problems–Physics

7.24 $P_L = 60\text{W}$, $I_L = 0.54\text{A}$

$$V_L = \frac{60}{0.54} = 110\text{V}.$$

The transformer is step-down and have $\frac{1}{2}$ input voltage. Hence

$$i_p = \frac{1}{2} \times I_2 = 0.27\text{A}.$$

7.25 A capacitor does not allow flow of direct current through it as the resistance across the gap is infinite. When an alternating voltage is applied across the capacitor plates, the plates are alternately charged and discharged. The current through the capacitor is a result of this changing voltage (or charge). Thus, a capacitor will pass more current through it if the voltage is changing at a faster rate, i.e. if the frequency of supply is higher. This implies that the reactance offered by a capacitor is less with increasing frequency; it is given by $1/\omega C$.

7.26 An inductor opposes flow of current through it by developing a back emf according to Lenz's law. The induced voltage has a polarity so as to maintain the current at its present value. If the current is decreasing, the polarity of the induced emf will be so as to increase the current and vice versa. Since the induced emf is proportional to the rate of change of current, it will provide greater reactance to the flow of current if the rate of change is faster, i.e. if the frequency is higher. The reactance of an inductor, therefore, is proportional to the frequency, being given by ωL .

7.27 Power $P = \frac{V^2}{Z} \Rightarrow \frac{50,000}{2000} = 25 = Z$

$$Z^2 = R^2 + (X_C - X_L)^2 = 625$$

$$\tan \phi = \frac{X_C - X_L}{R} = -\frac{3}{4}$$

$$625 = R^2 + \left(-\frac{3}{4}R\right)^2 = \frac{25}{16}$$

$$R^2 = 400 \Rightarrow R = 20\Omega$$

$$X_C - X_L = -15\Omega$$

$$I = \frac{V}{Z} = \frac{223}{25} \approx 9\text{A}.$$

$$I_M = \sqrt{2} \times 9 = 12.6\text{A}.$$

If R , X_C , X_L are all doubled, $\tan \phi$ does not change.

Z is doubled, current is halved.

Power drawn is halved.

7.28 (i) Resistance of Cu wires, R

$$= \rho \frac{l}{A} = \frac{1.7 \times 10^{-8} \times 20000}{\pi \times \left(\frac{1}{2}\right)^2 \times 10^{-4}} = 4 \Omega$$

$$I \text{ at } 220 \text{ V: } VI = 10^6 \text{ W}; I = \frac{10^6}{220} = 0.45 \times 10^4 \text{ A}$$

$RI^2 =$ Power loss

$$= 4 \times (0.45)^2 \times 10^8 \text{ W}$$

$$> 10^6 \text{ W}$$

This method cannot be used for transmission

(ii) $V'I' = 10^6 \text{ W} = 11000 I'$

$$I' = \frac{1}{1.1} \times 10^2$$

$$RI'^2 = \frac{1}{1.21} \times 4 \times 10^4 = 3.3 \times 10^4 \text{ W}$$

$$\text{Fraction of power loss} = \frac{3.3 \times 10^4}{10^6} = 3.3\%$$

7.29 $Ri_1 = v_m \sin \omega t$ $i_1 = \frac{v_m \sin \omega t}{R}$

$$\frac{q_2}{C} + L \frac{dq_2}{dt} = v_m \sin \omega t$$

Let $q_2 = q_m \sin(\omega t + \phi)$

$$q_m \left(\frac{q_m}{C} - L\omega^2 \right) \sin(\omega t + \phi) = v_m \sin \omega t$$

$$q_m = \frac{v_m}{\frac{1}{C} - L\omega^2}, \phi = 0; \frac{1}{C} - \omega^2 L > 0$$

Exemplar Problems–Physics

$$v_R = \frac{v_m}{L\omega^2 - \frac{1}{C}}, \phi = \pi L\omega^2 - \frac{1}{C} > 0$$

$$i_2 = \frac{dq_2}{dt} = \omega q_m \cos(\omega t + \phi)$$

i_1 and i_2 are out of phase. Let us assume $\frac{1}{C} - \omega^2 L > 0$

$$i_1 + i_2 = \frac{v_m \sin \omega t}{R} + \frac{v_m}{L\omega - \frac{1}{C\omega}} \cos \omega t$$

Now $A \sin \omega t + B \cos \omega t = C \sin(\omega t + \phi)$

$$C \cos \phi = A, C \sin \phi = B; C = \sqrt{A^2 + B^2}$$

$$\text{Therefore, } i_1 + i_2 = \left[\frac{v_m^2}{R^2} + \frac{v_m^2}{[\omega L - 1/\omega C]^2} \right]^{1/2} \sin(\omega t + \phi)$$

$$\phi = \tan^{-1} \frac{R}{X_L - X_C}$$

$$\frac{1}{Z} = \left\{ \frac{1}{R^2} + \frac{1}{(L\omega - 1/\omega C)^2} \right\}^{1/2}$$

7.30 $Li \frac{di}{dt} + Ri^2 + \frac{qi}{c} = vi$; $Li \frac{di}{dt} = \frac{d}{dt} \left(\frac{1}{2} Li^2 \right)$ = rate of change of energy stored in an inductor.

Ri^2 = joule heating loss

$$\frac{q}{C} i = \frac{d}{dt} \left(\frac{q^2}{2C} \right) = \text{rate of change of energy stored in the capacitor.}$$

vi = rate at which driving force pours in energy. It goes into (i) ohmic loss and (ii) increase of stored energy.

$$\int_0^T dt \frac{d}{dt} \left(\frac{1}{2} i^2 + \frac{q^2}{C} \right) + \int_0^T Ri^2 dt = \int_0^T v i dt$$

$$0 + (+ve) = \int_0^T v i dt$$

$$\int_0^T v i dt > 0 \text{ if phase difference, a constant is acute.}$$

7.31 (i) $L \frac{d^2 q}{dt^2} + R \frac{dq}{dt} + \frac{q}{C} = v_m \sin \omega t$

Let $q = q_m \sin (\omega t + \phi) = -q_m \cos (\omega t + \phi)$

$i = i_m \sin (\omega t + \phi) = q_m \omega \sin (\omega t + \phi)$

$$i_m = \frac{v_m}{Z} = \frac{v_m}{\sqrt{R^2 + (X_C - X_L)^2}}; \phi = \tan^{-1} \left(\frac{X_C - X_L}{R} \right)$$

(ii) $U_L = \frac{1}{2} L i^2 = \frac{1}{2} L \left[\frac{v_m}{\sqrt{R^2 + X_C - X_L)^2}} \right]^2 \sin^2 (\omega t_0 + \phi)$

$$U_C = \frac{1}{2} \frac{q^2}{C} = \frac{1}{2C} \left[\frac{v_m}{\sqrt{R^2 + (X_C - X_L)^2}} \right]^2 \frac{1}{\omega^2} \cos^2 (\omega t_0 + \phi)$$

(iii) Left to itself, it is an LC oscillator. The capacitor will go on discharging and all energy will go to L and back and forth.

Chapter 8

- 8.1** (c)
8.2 (b)
8.3 (b)
8.4 (d)
8.5 (d)
8.6 (c)
8.7 (c)
8.8 (a), (d)
8.9 (a), (b), (c)
8.10 (b), (d)

Exemplar Problems–Physics

8.11 (a), (c), (d)

8.12 (b), (d)

8.13 (a), (c), (d)

8.14 As electromagnetic waves are plane polarised, so the receiving antenna should be parallel to electric/magnetic part of the wave.

8.15 Frequency of the microwave matches the resonant frequency of water molecules.

8.16 $i_c = i_D = \frac{dq}{dt} = -2\pi q_0 \nu \sin 2\pi \nu t .$

8.17 On decreasing the frequency, reactance $X_c = \frac{1}{\omega C}$ will increase which will lead to decrease in conduction current. In this case $i_D = i_C$; hence displacement current will decrease.

8.18 $I_{av} = \frac{1}{2} c \frac{B_0^2}{\mu_0} = \frac{1}{2} \times \frac{3 \times 10^8 \times (12 \times 10^{-8})^2}{1.26 \times 10^{-6}} = 1.71 \text{ W/m}^2 .$

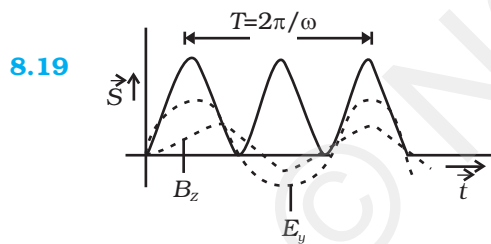

8.20 EM waves exert radiation pressure. Tails of comets are due to solar radiation.

8.21
$$B = \frac{\mu_0 2I_D}{4\pi r} = \frac{\mu_0 I}{4\pi r} = \frac{\mu_0}{2\pi r} \epsilon_0 \frac{d\phi_E}{dt}$$

$$= \frac{\mu_0 \epsilon_0}{2\pi r} \frac{d}{dt} (E\pi r^2)$$

$$= \frac{\mu_0 \epsilon_0 r}{2} \frac{dE}{dt} .$$

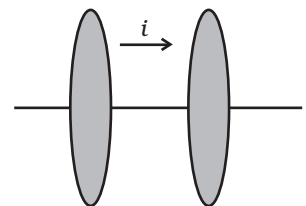

8.22 (a) $\lambda_1 \rightarrow$ Microwave, $\lambda_2 \rightarrow$ UV

$\lambda_3 \rightarrow$ X rays, $\lambda_4 \rightarrow$ Infrared

(b) $\lambda_3 < \lambda_2 < \lambda_4 < \lambda_1$

- (c) Microwave - Radar
 UV - LASIK eye surgery
 X-ray - Bone fracture identification (bone scanning)
 Infrared - Optical communication.

8.23 $S_{av} = c^2 \epsilon_0 |\mathbf{E}_0 \times \mathbf{B}_0| \frac{1}{T} \int_0^T \cos^2(kx - \omega t) dt$ as $\mathbf{S} = c^2 \epsilon_0 (\mathbf{E} \times \mathbf{B})$

$$= c^2 \epsilon_0 E_0 B_0 \frac{1}{T} \times \frac{T}{2}$$

$$= c^2 \epsilon_0 E_0 \left(\frac{E_0}{c} \right) \times \frac{1}{2} \left(\text{as } c = \frac{E_0}{B_0} \right)$$

$$= \frac{1}{2} \epsilon_0 E_0^2 c$$

$$= \frac{E_0^2}{2\mu_0 c} \text{ as } \left(c = \frac{1}{\sqrt{\mu_0 \epsilon_0}} \right)$$

8.24 $i_D = C \frac{dV}{dt}$

$$1 \times 10^{-3} = 2 \times 10^{-6} \frac{dV}{dt}$$

$$\frac{dV}{dt} = \frac{1}{2} \times 10^3 = 5 \times 10^2 \text{ V/s}$$

Hence, applying a varying potential difference of 5×10^2 V/s would produce a displacement current of desired value.

8.25 Pressure

$$P = \frac{\text{Force}}{\text{Area}} = \frac{F}{A} = \frac{1}{A} \frac{\Delta p}{\Delta t} \quad (F = \frac{\Delta p}{\Delta t} = \text{rate of change of momentum})$$

$$= \frac{1}{A} \cdot \frac{U}{\Delta t c} \quad (\Delta p c = \Delta U = \text{energy imparted by wave in time } \Delta t)$$

$$= \frac{I}{c} \left(\text{intensity } I = \frac{U}{A \Delta t} \right)$$

- 8.26** Intensity is reduced to one fourth. This is because the light beam spreads, as it propagates into a spherical region of area $4\pi r^2$, but LASER does not spread and hence its intensity remains constant.

Exemplar Problems–Physics

8.27 Electric field of an EM wave is an oscillating field and so is the electric force caused by it on a charged particle. This electric force averaged over an integral number of cycles is zero since its direction changes every half cycle. Hence, electric field is not responsible for radiation pressure.

$$\mathbf{E} = \frac{\lambda \hat{\mathbf{e}}_s}{2\pi\epsilon_0 a} \hat{\mathbf{j}}$$

$$\mathbf{B} = \frac{\mu_0 i}{2\pi a} \hat{\mathbf{i}}$$

$$= \frac{\mu_0 \lambda v}{2\pi a} \hat{\mathbf{i}}$$

$$\mathbf{S} = \frac{1}{\mu_0} (\mathbf{E} \times \mathbf{B}) = \frac{1}{\mu_0} \left(\frac{\lambda \hat{\mathbf{j}}_s}{2\pi\epsilon_0 a} \hat{\mathbf{j}} \times \frac{\mu_0 \lambda v}{2\pi a} \hat{\mathbf{i}} \right)$$

$$= \frac{-\lambda^2 v}{4\pi^2 \epsilon_0 a^2} \hat{\mathbf{k}}$$

8.29 Let the distance between the plates be d . Then the electric field

$E = \frac{V_0}{d} \sin(2\pi\nu t)$. The conduction current density is given by the Ohm's law $= E$.

$$\begin{aligned} \Rightarrow J^c &= \frac{1}{\rho} \frac{V_0}{d} \sin(2\pi\nu t) = \frac{V_0}{\rho d} \sin(2\pi\nu t) \\ &= J_0^c \sin 2\pi\nu t \end{aligned}$$

where $J_0^c = \frac{V_0}{\rho d}$.

The displacement current density is given as

$$J^d = \epsilon \frac{\partial E}{\partial t} = \epsilon \frac{\partial}{\partial t} \left\{ \frac{V_0}{d} \sin(2\pi\nu t) \right\}$$

$$= \frac{\epsilon 2\pi\nu V_0}{d} \cos(2\pi\nu t)$$

$$= J_0^d \cos(2\pi\nu t), \text{ where } J_0^d = \frac{2\pi\nu\epsilon V_0}{d}$$

$$\begin{aligned} \frac{J_0^d}{J_0^c} &= \frac{2\pi v \epsilon V_0}{d} \cdot \frac{\rho d}{V_0} = 2\pi v \epsilon \rho = 2\pi \times 80 \epsilon_0 v \times 0.25 = 4\pi \epsilon_0 v \times 10 \\ &= \frac{10v}{9 \times 10^9} = \frac{4}{9} \end{aligned}$$

8.30 (i) Displacement current density can be found from the relation

$$\text{be } \mathbf{J}_D = \epsilon_0 \frac{d\mathbf{E}}{dt}$$

$$= \epsilon_0 \mu_0 I_0 \frac{\partial}{\partial t} \cos(2\pi vt) \cdot \ln\left(\frac{s}{a}\right) \hat{\mathbf{k}}$$

$$= \frac{1}{c^2} I_0 2\pi v^2 (-\sin(2\pi vt)) \ln\left(\frac{s}{a}\right) \hat{\mathbf{k}}$$

$$= \left(\frac{v}{c}\right)^2 2\pi I_0 \sin(2\pi vt) \ln\left(\frac{a}{s}\right) \hat{\mathbf{k}}$$

$$= \frac{2\pi}{\lambda^2} I_0 \ln\left(\frac{a}{s}\right) \sin(2\pi vt) \hat{\mathbf{k}}$$

(ii) $I^d = \int J_D s ds d\theta$

$$= \frac{2\pi}{\lambda^2} I_0 2\pi \int_{s=0}^a \ln\left(\frac{a}{s}\right) s ds \sin(2\pi vt)$$

$$= \left(\frac{2\pi}{\lambda}\right)^2 I_0 \int_{s=0}^a \frac{1}{2} ds^2 \ln\left(\frac{a}{s}\right) \sin(2\pi vt)$$

$$= \frac{\alpha^2}{4} \left(\frac{2\pi}{\lambda}\right)^2 I_0 \int_{s=0}^a d\left(\frac{s}{a}\right)^2 \ln\left(\frac{a}{s}\right) \sin(2\pi vt)$$

$$= -\frac{\alpha^2}{4} \left(\frac{2\pi}{\lambda}\right)^2 I_0 \int_0^1 \ln \xi d\xi \sin(2\pi vt)$$

$$= +\left(\frac{\alpha}{2}\right)^2 \left(\frac{2\pi}{\lambda}\right)^2 I_0 \sin 2\pi vt \quad (\because \text{The integral has value } -1)$$

(iii) The displacement current

$$I^d = \left(\frac{\alpha}{2} \cdot \frac{2\pi}{\lambda}\right)^2 I_0 \sin 2\pi vt = I_0^d \sin 2\pi vt$$

$$\frac{I_0^d}{I_0} = \left(\frac{\alpha\pi}{\lambda}\right)^2$$

8.31

(i) $\oint \mathbf{E} \cdot d\mathbf{l} = \int_1^2 \mathbf{E} \cdot d\mathbf{l} + \int_2^3 \mathbf{E} \cdot d\mathbf{l} + \int_3^4 \mathbf{E} \cdot d\mathbf{l} + \int_4^1 \mathbf{E} \cdot d\mathbf{l}$

$$= \int_1^2 E \cdot dl \cos 90^\circ + \int_2^3 E \cdot dl \cos 0 + \int_3^4 E \cdot dl \cos 90^\circ + \int_4^1 E \cdot dl \cos 180^\circ$$

$$= E_0 h [\sin(kz_2 - \omega t) - \sin(kz_1 - \omega t)]$$

(ii) For evaluating $\int \mathbf{B} \cdot d\mathbf{s}$ let us consider the rectangle 1234 to be made of strips of area $ds = h dz$ each.

$$\int \mathbf{B} \cdot d\mathbf{s} = \int B ds \cos 0 = \int B ds = \int_{z_1}^{z_2} B_0 \sin(kz - \omega t) h dz$$

$$= \frac{-B_0 h}{k} [\cos(kz_2 - \omega t) - \cos(kz_1 - \omega t)]$$

(iii) $\oint \mathbf{E} \cdot d\mathbf{l} = \frac{-d\phi_B}{dt}$

Using the relations obtained in Equations (1) and (2) and simplifying, we get

$$E_0 h [\sin(kz_2 - \omega t) - \sin(kz_1 - \omega t)] = \frac{B_0 h}{k} \omega [\sin(kz_2 - \omega t) - \sin(kz_1 - \omega t)]$$

$$E_0 = B_0 \frac{\omega}{k}$$

$$\frac{E_0}{B_0} = c$$

(iv) For evaluating $\oint \mathbf{B} \cdot d\mathbf{l}$, let us consider the loop 1234 in yz plane as shown in Fig.

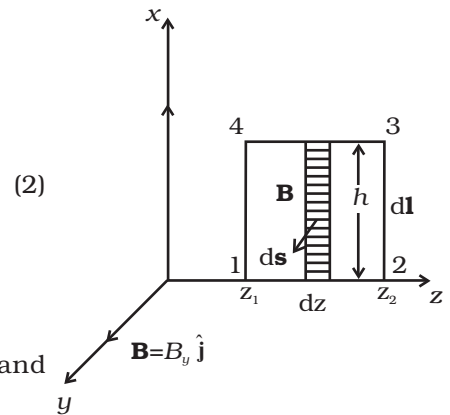
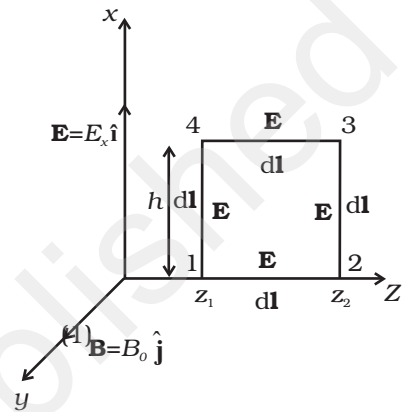

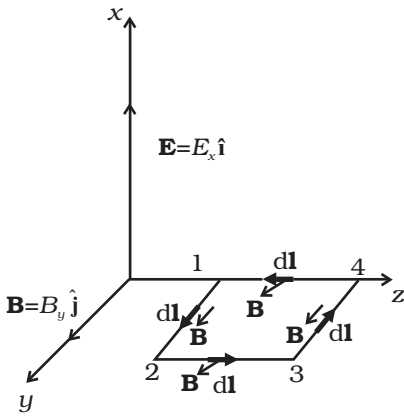

$$\begin{aligned} \oint \mathbf{B} \cdot d\mathbf{l} &= \int_1^2 \mathbf{B} \cdot d\mathbf{l} + \int_2^3 \mathbf{B} \cdot d\mathbf{l} + \int_3^4 \mathbf{B} \cdot d\mathbf{l} + \int_4^1 \mathbf{B} \cdot d\mathbf{l} \\ &= \int_1^2 B dl \cos 0 + \int_2^3 B dl \cos 90^\circ + \int_3^4 B dl \cos 180^\circ + \int_4^1 B dl \cos 90^\circ \\ &= B_0 h [\sin(kz_1 - \omega t) - \sin(kz_2 - \omega t)] \end{aligned} \quad (3)$$

Now to evaluate $\phi_E = \int \mathbf{E} \cdot d\mathbf{s}$, let us consider the rectangle 1234 to be made of strips of area $h dz$ each.

$$\begin{aligned} \phi_E &= \int \mathbf{E} \cdot d\mathbf{s} = \int E ds \cos 0 = \int E ds = \int_{z_1}^{z_2} E_0 \sin(kz_1 - \omega t) h dz \\ &= \frac{-E_0 h}{k} [\cos(kz_2 - \omega t) - \cos(kz_1 - \omega t)] \\ \therefore \frac{d\phi_E}{dt} &= \frac{E_0 h \omega}{k} [\sin(kz_1 - \omega t) - \sin(kz_2 - \omega t)] \end{aligned} \quad (4)$$

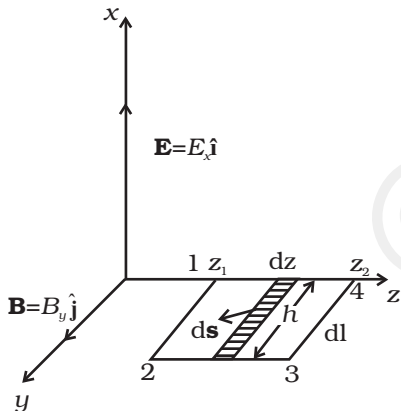

In $\oint \mathbf{B} \cdot d\mathbf{l} = \mu_0 \left(I + \epsilon_0 \frac{d\phi_E}{dt} \right)$, I = conduction current
 = 0 in vacuum.

$$\therefore \oint \mathbf{B} \cdot d\mathbf{l} = \mu_0 \epsilon_0 \frac{d\phi_E}{dt}$$

Using relations obtained in Equations (3) and (4) and simplifying, we get

$$B_0 = E_0 \frac{\omega}{k} \mu_0 \epsilon_0$$

$$\frac{E_0}{B_0} \frac{\omega}{k} = \frac{1}{\mu_0 \epsilon_0} \text{ But } E_0/B_0 = c, \text{ and } \omega = ck$$

$$\text{or } c \cdot c = \frac{1}{\mu_0 \epsilon_0} \text{ Therefore, } c = \frac{1}{\sqrt{\mu_0 \epsilon_0}}$$

8.32 (a) E - field contribution is $u_E = \frac{1}{2} \epsilon_0 E^2$

B - field contribution is $u_B = \frac{1}{2} \frac{B^2}{\mu_0}$

Total energy density $u = u_E + u_B = \frac{1}{2} \epsilon_0 E^2 + \frac{1}{2} \frac{B^2}{\mu_0}$ (1)

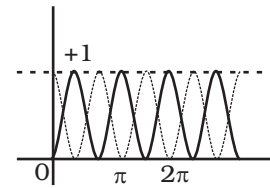

The values of E^2 and B^2 vary from point to point and from moment to moment. Hence, the effective values of E^2 and B^2 are their time averages.

$$(E^2)_{av} = E_0^2 [\sin^2(kz - \omega t)]_{av}$$

$$(B^2)_{av} = (B^2)_{av} = B_0^2 [\sin^2(kz - \omega t)]_{av}$$

The graph of $\sin^2\theta$ and $\cos^2\theta$ are identical in shape but shifted by $\pi/2$, so the average values of $\sin^2\theta$ and $\cos^2\theta$ are also equal over any integral multiple of π .

and also $\sin^2\theta + \cos^2\theta = 1$

So by symmetry the average of $\sin^2\theta = \text{average of } \cos^2\theta = \frac{1}{2}$

$$\therefore (E^2)_{av} = \frac{1}{2} E_0^2 \text{ and } (B^2)_{av} = \frac{1}{2} B_0^2$$

Substituting in Equation (1),

$$u = \frac{1}{4} \epsilon_0 E^2 + \frac{1}{4} \frac{B_0^2}{\mu} \quad (2)$$

(b) We know $\frac{E_0}{B_0} = c$ and $c = \frac{1}{\sqrt{\mu_0 \epsilon_0}} \therefore \frac{1}{4} \frac{B_0^2}{\mu_0} = \frac{E_0^2 / c^2}{4\mu_0} = \frac{E_0^2}{4\mu_0} \mu_0 \epsilon_0 = \frac{1}{4} \epsilon_0 E_0^2$.

Therefore, $u_{av} = \frac{1}{4} \epsilon_0 E_0^2 + \frac{1}{4} \epsilon_0 E_0^2 = \frac{1}{2} \epsilon_0 E_0^2$, and $I_{av} = u_{av} c = \frac{1}{2} \epsilon_0 E_0^2 c$.

Chapter 9

9.1 (a)

9.2 (d)

9.3 (c)

- 9.4 (b)
 9.5 (c)
 9.6 (c)
 9.7 (b)
 9.8 (b)
 9.9 (b)
 9.10 (d)
 9.11 (a)
 9.12 (a), (b), (c)
 9.13 (d)
 9.14 (a), (d)
 9.15 (a), (b)
 9.16 (a), (b), (c)
 9.17 As the refractive index for red is less than that for blue, parallel beams of light incident on a lens will be bent more towards the axis for blue light compared to red. Thus the focal length for blue light will be smaller than that for red.
 9.18 The near vision of an average person is 25cm. To view an object with magnification 10,

$$m = \frac{D}{f} \Rightarrow f = \frac{D}{m} = \frac{25}{10} = 2.5 = 0.025\text{m}$$

$$P = \frac{1}{0.025} = 40 \text{ diopters.}$$

- 9.19 No. The reversibility of the lens makes equation.
 9.20 Let the apparent depth be O_1 for the object seen from μ_2 then

$$O_1 = \frac{\mu_2}{\mu_1} \frac{h}{3}$$

If seen from μ_3 the apparent depth is O_2 .

$$O_2 = \frac{\mu_3}{\mu_2} \left(\frac{h}{3} + O_1 \right) = \frac{\mu_3}{\mu_2} \left(\frac{h}{3} + \frac{\mu_2}{\mu_1} \frac{h}{3} \right) = \frac{h}{3} \left(\frac{\mu_3}{\mu_2} + \frac{\mu_3}{\mu_1} \right)$$

Seen from outside, the apparent height is

Exemplar Problems–Physics

$$O_3 = \frac{1}{\mu_3} \left(\frac{h}{3} + O_2 \right) = \frac{1}{\mu_3} \left[\frac{h}{3} + \frac{h}{3} \left(\frac{\mu_3 + \mu_3}{\mu_2 + \mu_1} \right) \right]$$

$$= \frac{h}{3} \left(\frac{1}{\mu_1} + \frac{1}{\mu_2} + \frac{1}{\mu_3} \right)$$

9.21 At minimum deviation

$$\mu = \frac{\sin \left[\frac{(A + D_m)}{2} \right]}{\sin \left(\frac{A}{2} \right)}$$

\therefore Given $D_m = A$

$$\therefore \mu = \frac{\sin A}{\sin \frac{A}{2}} = \frac{2 \sin \frac{A}{2} \cos \frac{A}{2}}{\sin \frac{A}{2}} = 2 \cos \frac{A}{2}$$

$$\therefore \cos \frac{A}{2} = \frac{\sqrt{3}}{2} \text{ or } \frac{A}{2} = 30^\circ \therefore A = 60^\circ$$

9.22 Let the two ends of the object be at distance $u_1 = u - L/2$ and $u_2 = u + L/2$, respectively, so that $|u_1 - u_2| = L$. Let the image of the two ends be formed at v_1 and v_2 , so that the image length would be

$L' = |v_1 - v_2|$. Since $\frac{1}{u} + \frac{1}{v} = \frac{1}{f}$ or $v = \frac{fu}{u-f}$ the image of the two ends will

$$\text{be at } v_1 = \frac{f(u-L/2)}{u-f-L/2}, \quad v_2 = \frac{f(u+L/2)}{u-f+L/2}$$

Hence

$$L' = |v_1 - v_2| = \frac{f^2 L}{(u-f)^2 \times L^2 / 4}$$

Since the object is short and kept away from focus, we have

$$L^2/4 \ll (u-f)^2$$

Hence finally

$$L' = \frac{f^2}{(u-f)^2} L.$$

9.23 Referring to the Fig., AM is the direction of incidence ray before liquid is filled. After liquid is filled, BM is the direction of the incident ray. Refracted ray in both cases is same as that along AM.

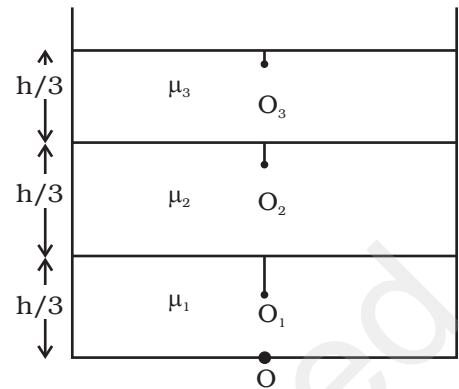

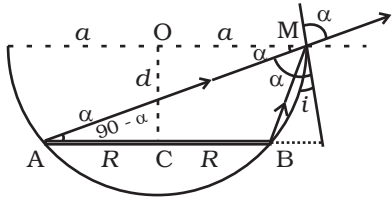

$$\frac{1}{\mu} = \frac{\sin i}{\sin r} = \frac{\sin i}{\sin \alpha}$$

$$\sin i = \frac{a - R}{\sqrt{d^2 + (a - R)^2}} \quad \text{and} \quad \sin \alpha = \cos(90 - \alpha) = \frac{a + R}{\sqrt{d^2 + (a - R)^2}}$$

Substituting, we get $d = \frac{\mu(a^2 - R^2)}{\sqrt{(a + R)^2 - \mu(a - R)^2}}$

9.24

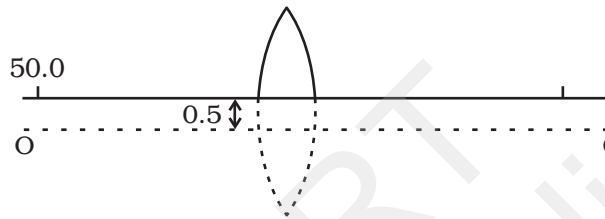

If there was no cut then the object would have been at a height of 0.5 cm from the principal axis OO' . Consider the image for this case.

$$\frac{1}{v} - \frac{1}{u} = \frac{1}{f}$$

$$\therefore \frac{1}{v} = \frac{1}{u} + \frac{1}{f} = \frac{1}{-50} + \frac{1}{25} = \frac{1}{50}$$

$$\therefore v = 50 \text{ cm.}$$

Magnification is $m = \frac{v}{u} = -\frac{50}{50} = -1$.

Thus the image would have been formed at 50 cm from the pole and 0.5 cm below the principal axis.

Hence with respect to the X axis passing through the edge of the cut lens, the co-ordinates of the image are

(50 cm, -1 cm)

9.25 From the reversibility of u and v , as seen from the formula for lens,

$$\frac{1}{f} = \frac{1}{v} - \frac{1}{u}$$

It is clear that there are two positions for which there shall be an image on the screen.

Let the first position be when the lens is at O.

$$\text{Given } -u + v = D$$

$$\Rightarrow u = -(D - v)$$

Placing it in the lens formula

$$\frac{1}{D - v} + \frac{1}{v} = \frac{1}{f}$$

Exemplar Problems–Physics

$$\Rightarrow \frac{v+D-v}{(D-v)v} = \frac{1}{f}$$

$$\Rightarrow v^2 - Dv + Df = 0$$

$$\Rightarrow v = \frac{D}{2} \pm \frac{\sqrt{D^2 - 4Df}}{2}$$

$$u = -(D - v) = -\left(\frac{D}{2} \pm \frac{\sqrt{D^2 - 4Df}}{2}\right)$$

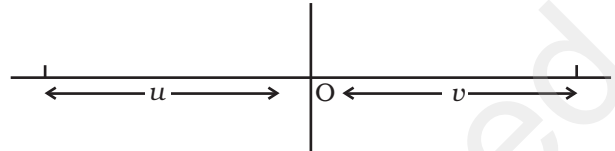

Thus, if the object distance is

$$\frac{D}{2} - \frac{\sqrt{D^2 - 4Df}}{2} \text{ then the image is at}$$

$$\frac{D}{2} + \frac{\sqrt{D^2 - 4Df}}{2}$$

If the object distance is $\frac{D}{2} + \frac{\sqrt{D^2 - 4Df}}{2}$, then the image is at

$$\frac{D}{2} - \frac{\sqrt{D^2 - 4Df}}{2}$$

The distance between the poles for these two object distances is

$$\frac{D}{2} + \frac{\sqrt{D^2 - 4Df}}{2} - \left(\frac{D}{2} - \frac{\sqrt{D^2 - 4Df}}{2}\right) = \sqrt{D^2 - 4Df}$$

$$\text{Let } d = \sqrt{D^2 - 4Df}$$

$$\text{If } u = \frac{D}{2} + \frac{d}{2} \text{ then the image is at } v = \frac{D}{2} - \frac{d}{2}$$

$$\therefore \text{The magnification } m_1 = \frac{D-d}{D+d}$$

$$\text{If } u = \frac{D-d}{2} \text{ then } v = \frac{D+d}{2}$$

$$\therefore \text{The magnification } m_2 = \frac{D+d}{D-d} \text{ Thus } \frac{m_2}{m_1} = \left(\frac{D+d}{D-d}\right)^2$$

- 9.26** Let d be the diameter of the disc. The spot shall be invisible if the incident rays from the dot at O to the surface at $\frac{d}{2}$ are at the critical angle.

Let i be the angle of incidence.

$$\text{Then } \sin i = \frac{1}{\mu}$$

$$\text{Now, } \frac{d/2}{h} = \tan i$$

$$\Rightarrow \frac{d}{2} = h \tan i = h [\sqrt{\mu^2 - 1}]^{-1}$$

$$\therefore d = \frac{2h}{\sqrt{\mu^2 - 1}}$$

9.27 (i) Let the power at the far point be P_f for the normal relaxed eye.

$$\text{Then } P_f = \frac{1}{f} = \frac{1}{0.1} + \frac{1}{0.02} = 60 \text{ D}$$

With the corrective lens the object distance at the far point is ∞ . The power required is

$$P'_f = \frac{1}{f'} = \frac{1}{\infty} + \frac{1}{0.02} = 50 \text{ D}$$

The effective power of the relaxed eye with glasses is the sum of the eye and that of the glasses P_g .

$$\therefore P'_f = P_f + P_g$$

$$\therefore P_g = -10 \text{ D.}$$

(ii) His power of accommodation is 4 diopters for the normal eye. Let the power of the normal eye for near vision be P_n .

$$\text{Then } 4 = P_n - P_f \text{ or } P_n = 64 \text{ D.}$$

Let his near point be x_n , then

$$\frac{1}{x_n} + \frac{1}{0.02} = 64 \text{ or } \frac{1}{x_n} + 50 = 64$$

$$\frac{1}{x_n} = 14,$$

$$\therefore x_n = \frac{1}{14}; 0.07 \text{ m}$$

(iii) With glasses $P'_n = P'_f + 4 = 54$

$$54 = \frac{1}{x'_n} + \frac{1}{0.02} = \frac{1}{x'_n} + 50$$

$$\frac{1}{x'_n} = 4,$$

$$\therefore x'_n = \frac{1}{4} = 0.25 \text{ m.}$$

9.28 Any ray entering at an angle i shall be guided along AC if the angle the ray makes with the face AC (ϕ) is greater than the critical angle.

$$\Rightarrow \sin r \geq \frac{1}{\mu}$$

$$\Rightarrow \cos r \geq \frac{1}{\mu}$$

$$\text{Or, } 1 - \cos^2 r \leq 1 - \frac{1}{\mu^2}$$

$$\text{i.e. } \sin^2 r \leq 1 - \frac{1}{\mu^2}$$

$$\text{Since } \sin i = \mu \sin r$$

$$\frac{1}{\mu^2} \sin^2 i \leq 1 - \frac{1}{\mu^2}$$

$$\text{Or, } \sin^2 i \leq \mu^2 - 1$$

The smallest angle ϕ shall be when $i = \frac{\pi}{2}$. If that is greater than the critical angle then all other angles of incidence shall be more than the critical angle.

$$\text{Thus } 1 \leq \mu^2 - 1$$

$$\text{Or, } \mu^2 \geq 2$$

$$\Rightarrow \mu \geq \sqrt{2}$$

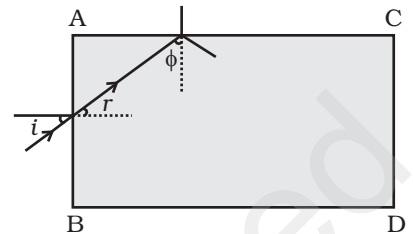

9.29 Consider a portion of a ray between x and $x + dx$ inside the liquid. Let the angle of incidence at x be θ and let it enter the thin column at height y . Because of the bending it shall emerge at $x + dx$ with an angle $\theta + d\theta$ and at a height $y + dy$. From Snell's law

$$\mu(y) \sin \theta = \mu(y+dy) \sin (\theta+d\theta)$$

$$\text{or } \mu(y) \sin \theta ; \left(\mu(y) + \frac{d\mu}{dy} dy \right) (\sin \theta \cos d\theta + \cos \theta \sin d\theta)$$

$$; \mu(y) \sin \theta + \mu(y) \cos \theta d\theta + \frac{d\mu}{dy} dy \sin \theta$$

$$\text{or } \mu(y) \cos \theta d\theta ; \frac{-d\mu}{dy} dy \sin \theta$$

$$d\theta ; \frac{-1}{\mu} \frac{d\mu}{dy} dy \tan \theta$$

$$\text{But } \tan \theta = \frac{dx}{dy} \text{ (from the fig.)}$$

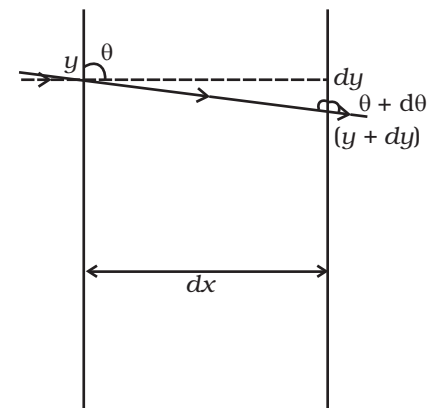

$$\therefore d\theta = \frac{-1}{\mu} \frac{d\mu}{dy} dx$$

$$\therefore \theta = \frac{-1}{\mu} \frac{d\mu}{dy} \int dx = \frac{-1}{\mu} \frac{d\mu}{dy} d$$

9.30 Consider two planes at r and $r + dr$. Let the light be incident at an angle θ at the plane at r and leave $r + dr$ at an angle $\theta + d\theta$

Then from Snell's law

$$n(r) \sin\theta = n(r + dr) \sin(\theta + d\theta)$$

$$\Rightarrow n(r) \sin\theta ; \left(n(r) + \frac{dn}{dr} dr \right) (\sin\theta \cos d\theta + \cos\theta \sin d\theta)$$

$$; \left(n(r) + \frac{dn}{dr} dr \right) (\sin\theta + \cos\theta d\theta)$$

Neglecting products of differentials

$$n(r) \sin\theta ; n(r) \sin\theta + \frac{dn}{dr} dr \sin\theta + n(r) \cos\theta d\theta$$

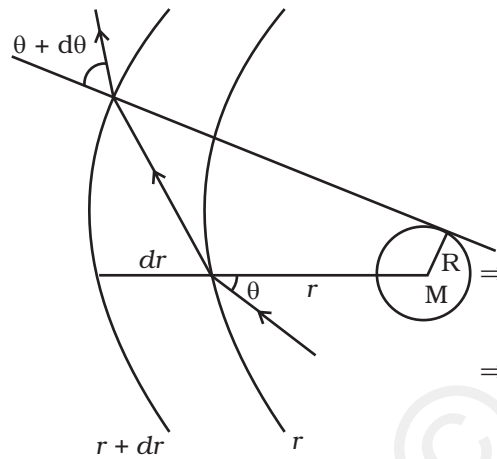

$$\Rightarrow -\frac{dn}{dr} \tan\theta = n(r) \frac{d\theta}{dr}$$

$$\Rightarrow \frac{2GM}{r^2 c^2} \tan\theta = \left(1 + \frac{2GM}{rc^2} \right) \frac{d\theta}{dr} \approx \frac{d\theta}{dr}$$

$$\therefore \int_0^{\theta_0} d\theta = \frac{2GM}{c^2} \int_{-\infty}^{\infty} \frac{\tan\theta dr}{r^2}$$

$$\text{Now } r^2 = x^2 + R^2 \text{ and } \tan\theta = \frac{R}{x}$$

$$2rdr = 2xdx$$

$$\int_0^{\theta_0} d\theta = \frac{2GM}{c^2} \int_{-\infty}^{\infty} \frac{R}{x} \frac{xdx}{(x^2 + R^2)^2}$$

$$\text{Put } x = R \tan\phi$$

$$dx = R \sec^2\phi d\phi$$

$$\therefore \theta_0 = \frac{2GMR}{c^2} \int_{-\pi/2}^{\pi/2} \frac{R \sec^2\phi d\phi}{R^3 \sec^3\phi}$$

$$= \frac{2GM}{Rc^2} \int_{-\pi/2}^{\pi/2} \cos\phi d\phi = \frac{4GM}{Rc^2}$$

Exemplar Problems-Physics

9.31 As the material is of refractive index -1 , θ_r is negative and θ_i' positive.

$$\text{Now } |\theta_i| = |\theta_r| = |\theta_i'|$$

The total deviation of the outgoing ray from the incoming ray is $4\theta_i$.
Rays shall not reach the receiving plate if

$$\frac{\pi}{2} \leq 4\theta_i \leq \frac{3\pi}{2} \quad (\text{angles measured clockwise from the } y \text{ axis})$$

$$\frac{\pi}{8} \leq \theta_i \leq \frac{3\pi}{8}$$

$$\text{Now } \sin \theta_i = \frac{x}{R}$$

$$\frac{\pi}{8} \leq \sin^{-1} \frac{x}{R} \leq \frac{3\pi}{8}$$

$$\text{Or, } \frac{\pi}{8} \leq \frac{x}{R} \leq \frac{3\pi}{8}$$

Thus for $\frac{R\pi}{8} \leq x \leq \frac{R3\pi}{8}$ light emitted from the source shall not reach the receiving plate.

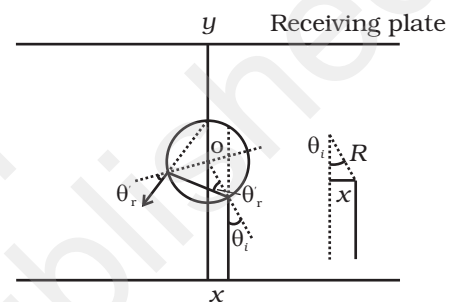

9.32 (i) The time required to travel from S to P_1 is

$$t_1 = \frac{SP_1}{c} = \frac{\sqrt{u^2 + b^2}}{c}; \quad \frac{u}{c} \left(1 + \frac{1}{2} \frac{b^2}{u^2} \right) \text{ assuming } b \ll u_0$$

The time required to travel from P_1 to O is

$$t_2 = \frac{P_1O}{c} = \frac{\sqrt{v^2 + b^2}}{c}; \quad \frac{v}{c} \left(1 + \frac{1}{2} \frac{b^2}{v^2} \right)$$

The time required to travel through the lens is

$$t_l = \frac{(n-1)w(b)}{c} \text{ where } n \text{ is the refractive index.}$$

Thus the total time is

$$t = \frac{1}{c} \left[u + v + \frac{1}{2} b^2 \left(\frac{1}{u} + \frac{1}{v} \right) + (n-1)w(b) \right]. \text{ Put } \frac{1}{D} = \frac{1}{u} + \frac{1}{v}$$

$$\text{Then } t = \frac{1}{c} \left(u + v + \frac{1}{2} \frac{b^2}{D} + (n-1) \left(w_0 + \frac{b^2}{\alpha} \right) \right)$$

Fermet's principle gives

$$\frac{dt}{db} = 0 = \frac{b}{CD} - \frac{2(n-1)b}{c\alpha}$$

$$\alpha = 2(n-1)D$$

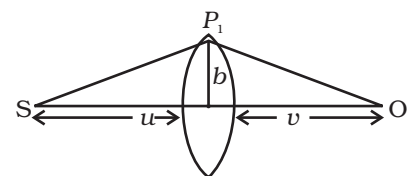

Thus a convergent lens is formed if $\alpha = 2(n - 1)D$. This is independent of b and hence all paraxial rays from S will converge at O (i.e. for rays $b \ll n$ and $b \ll v$).

Since $\frac{1}{D} = \frac{1}{u} + \frac{1}{v}$, the focal length is D .

(ii) In this case

$$t = \frac{1}{c} \left(u + v + \frac{1}{2} \frac{b^2}{D} + (n - 1) k_1 \ln \left(\frac{k_2}{b} \right) \right)$$

$$\frac{dt}{db} = 0 = \frac{b}{D} - (n - 1) \frac{k_1}{b}$$

$$\Rightarrow b^2 = (n - 1) k_1 D$$

$$\therefore b = \sqrt{(n - 1) k_1 D}$$

Thus all rays passing at a height b shall contribute to the image. The ray paths make an angle

$$\beta; \frac{b}{v} = \frac{\sqrt{(n - 1) k_1 D}}{v^2} = \sqrt{\frac{(n - 1) k_1 u v}{v^2 (u + v)}} = \sqrt{\frac{(n - 1) k_1 u}{(u + v) v}}$$

Chapter 10

10.1 (c)

10.2 (a)

10.3 (a)

10.4 (c)

10.5 (d)

10.6 (a), (b), (d)

10.7 (b), (d)

10.8 (a), (b)

10.9 (a), (b)

10.10 Yes.

10.11 Spherical.

10.12 Spherical with huge radius as compared to the earth's radius so that it is almost a plane.

10.13 Sound wave have frequencies 20 Hz to 20 kHz. The corresponding wavelengths are 15m and 15mm, respectively. Diffraction effects are seen if there are slits of width a such that.

$$\alpha: \lambda.$$

Exemplar Problems–Physics

For light waves, wavelengths $\approx 10^{-7}$ m. Thus diffraction effects will show when

$$a : 10^{-7} \text{ m.}$$

whereas for sound they will show for

$$15\text{mm} < a < 15\text{m} .$$

- 10.14** The linear distance between two dots is $l = \frac{2.54}{300} \text{ cm} ; 0.84 \times 10^{-2} \text{ cm}$.

At a distance of Z cm this subtends an angle.

$$\phi : l/z \therefore z = \frac{l}{\phi} = \frac{0.84 \times 10^{-2} \text{ cm}}{5.8 \times 10^{-4}} : 14.5 \text{ cm} .$$

- 10.15** Only in the special cases when the pass axis of (III) is parallel to (I) or (II) there shall be no light emerging. In all other cases there shall be light emerging because the pass axis of (II) is no longer perpendicular to the pass axis of (III).

- 10.16** Polarisation by reflection occurs when the angle of incidence is the

Brewster's angle i.e. $\tan \theta_B = \frac{n_2}{n_1}$ where $n_2 < n_1$.

When light travels in such a medium the critical angle is $\sin \theta_c = \frac{n_2}{n_1}$

where $n_2 < n_1$.

As $|\tan \theta_B| > |\sin \theta_c|$ for large angles, $\theta_B < \theta_c$.

Thus, polarisation by reflection shall definitely occur.

- 10.17** $d_{\min} = \frac{1.22\lambda}{2 \sin \beta}$

where β is the angle subtended by the objective at the object.

For light of 5500 \AA

$$d_{\min} = \frac{1.22 \times 5.5 \times 10^{-7}}{2 \sin \beta} \text{ m}$$

For electrons accelerated through 100V the deBroglie wavelength is

$$\lambda = \frac{h}{p} = \frac{1.227}{\sqrt{100}} = 0.1227 \text{ nm} = 0.1227 \times 10^{-9} \text{ m}$$

$$\therefore d'_{\min} = \frac{1.22 \times 1.227 \times 10^{-10}}{2 \sin \beta}$$

$$\therefore d'_{\min} = \frac{1.22 \times 1.3 \times 10^{-10}}{2 \sin \beta}$$

$$\frac{d'_{\min}}{d_{\min}} = \frac{1.3 \times 10^{-10}}{5.5 \times 10^{-7}} : 0.2 \times 10^{-3}$$

10.18 $T_2P = D + x, T_1P = D - x$

$$S_1P = \sqrt{(S_1T_1)^2 + (PT_1)^2}$$

$$= [D^2 + (D - x)^2]^{1/2}$$

$$S_2P = [D^2 + (D + x)^2]^{1/2}$$

Minima will occur when

$$[D^2 + (D + x)^2]^{1/2} - [D^2 + (D - x)^2]^{1/2} = \frac{\lambda}{2}$$

If $x = D$

$$(D^2 + 4D^2)^{1/2} = \frac{\lambda}{2}$$

$$(5D^2)^{1/2} = \frac{\lambda}{2}, \therefore D = \frac{\lambda}{2\sqrt{5}}$$

10.19 Without P:

$$A = A_{\perp} + A_{11}$$

$$A_{\perp} = A_{\perp}^1 + A_{\perp}^2 = A_{\perp}^0 \sin(kx - \omega t) + A_{\perp}^0 \sin(kx - \omega t + \phi)$$

$$A_{11} = A_{11}^{(1)} + A_{11}^{(2)}$$

$$A_{11} = A_{11}^0 [\sin(kx - \omega t) + \sin(kx - \omega t + \phi)]$$

where A_{\perp}^0, A_{11}^0 are the amplitudes of either of the beam in \perp and 11 polarizations.

\therefore Intensity =

$$= \left\{ |A_{\perp}^0|^2 + |A_{11}^0|^2 \right\} [\sin^2(kx - \omega t)(1 + \cos^2 \phi + 2 \sin \phi) + \sin^2(kx - \omega t) \sin^2 \phi]_{\text{average}}$$

$$= \left\{ |A_{\perp}^0|^2 + |A_{11}^0|^2 \right\} \left(\frac{1}{2} \right) \cdot 2(1 + \cos \phi)$$

Exemplar Problems–Physics

$$= 2|A_{\perp}^0|^2 \cdot (1 + \cos \phi) \text{ since } |A_{\perp}^0|_{\text{average}} = |A_{11}^0|_{\text{average}}$$

With P:

Assume A_{\perp}^2 is blocked:

$$\text{Intensity} = (A_{11}^1 + A_{11}^2)^2 + (A_{\perp}^1)^2$$

$$= |A_{\perp}^0|^2 (1 + \cos \phi) + |A_{\perp}^0|^2 \cdot \frac{1}{2}$$

Given: $I_0 = 4|A_{\perp}^0|^2 = \text{Intensity without polariser at principal maxima.}$

Intensity at principal maxima with polariser

$$= |A_{\perp}^0|^2 \left(2 + \frac{1}{2} \right)$$

$$= \frac{5}{8} I_0$$

Intensity at first minima with polariser

$$= |A_{\perp}^0|^2 (1 - 1) + \frac{|A_{\perp}^0|^2}{2}$$

$$= \frac{I_0}{8}$$

10.20 Path difference = $2d \sin \theta + (\mu - 1)l$

\therefore For principal maxima,

$$2d \sin \theta + 0.5l = 0$$

$$\sin \theta_0 = \frac{-l}{4d} = \frac{-1}{16} \quad \left(Ql = \frac{d}{4} \right)$$

$$\therefore OP = D \tan \theta_0 \approx -\frac{D}{16}$$

For the first minima:

$$\therefore 2d \sin \theta_1 + 0.5l = \pm \frac{\lambda}{2}$$

$$\sin\theta_1 = \frac{\pm\lambda/2 - 0.5\lambda}{2d} = \frac{\pm\lambda/2 - \lambda/8}{2\lambda} = \pm\frac{1}{4} - \frac{1}{16}$$

On the positive side: $\sin\theta^+ = \frac{3}{16}$

On the negative side: $\sin\theta^- = -\frac{5}{16}$

The first principal maxima on the positive side is at distance

$$D \tan\theta^+ = D \frac{\sin\theta^+}{\sqrt{1 - \sin^2\theta^+}} = D \frac{3}{\sqrt{16^2 - 3^2}} \text{ above O.}$$

In the -ve side, the distance will be $D \tan\theta^- = \frac{5}{\sqrt{16^2 - 5^2}}$ below O.

- 10.21** (i) Consider the disturbances at R_1 which is a distance d from A. Let the wave at R_1 because of A be $Y_A = a \cos \omega t$. The path difference of the signal from A with that from B is $\lambda/2$ and hence the phase difference is π .

Thus the wave at R_1 because of B is

$$y_B = a \cos(\omega t - \pi) = -a \cos \omega t.$$

The path difference of the signal from C with that from A is λ and hence the phase difference is 2π .

Thus the wave at R_1 because of C is $y_c = a \cos \omega t$.

The path difference between the signal from D with that of A is

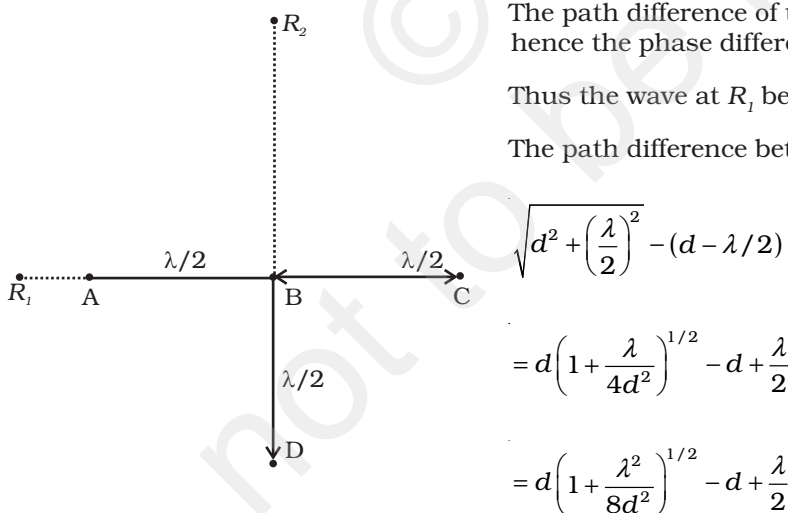

$$\begin{aligned} & \sqrt{d^2 + \left(\frac{\lambda}{2}\right)^2} - (d - \lambda/2) \\ &= d \left(1 + \frac{\lambda}{4d^2}\right)^{1/2} - d + \frac{\lambda}{2} \\ &= d \left(1 + \frac{\lambda^2}{8d^2}\right)^{1/2} - d + \frac{\lambda}{2} \end{aligned}$$

If $d \gg \lambda$ the path difference : $\frac{\lambda}{2}$ and hence the phase difference is π .

$$\therefore y_D = -a \cos \omega t .$$

Thus, the signal picked up at R_1 is

$$y_A + y_B + y_C + y_D = 0$$

Let the signal picked up at R_2 from B be $y_B = a_1 \cos \omega t$.

The path difference between signal at D and that at B is $\lambda/2$.

$$\therefore y_D = -a_1 \cos \omega t$$

The path difference between signal at A and that at B is

$$\sqrt{(d)^2 + \left(\frac{\lambda}{2}\right)^2} - d = d \left(1 + \frac{\lambda^2}{4d^2}\right)^{1/2} - d : \frac{1}{8} \frac{\lambda^2}{d^2}$$

$$\therefore \text{The phase difference is } \frac{2\pi}{\lambda} \cdot \frac{\lambda^2}{8d^2} = \frac{\pi\lambda}{4d} = \phi : 0.$$

Hence, $y_A = a_1 \cos (\omega t - \phi)$

Similarly, $y_C = a_1 \cos (\omega t - \phi)$

\therefore Signal picked up by R_2 is

$$y_A + y_B + y_C + y_D = y = 2a_1 \cos (\omega t - \phi)$$

$$\therefore |y|^2 = 4a_1^2 \cos^2 (\omega t - \phi)$$

$$\therefore \langle I \rangle = 2a_1^2$$

Thus R_1 picks up the larger signal.

(ii) If B is switched off,

R_1 picks up $y = a \cos \omega t$

$$\therefore \langle I_{R_1} \rangle = \frac{1}{2} a^2$$

R_2 picks up $y = a \cos \omega t$

$$\therefore \langle I_{R_2} \rangle = \frac{1}{2} a^2$$

Thus R_1 and R_2 pick up the same signal.

(c) If D is switched off.

R_1 picks up $y = a \cos \omega t$

$$\therefore \langle I_{R_1} \rangle = \frac{1}{2} a^2$$

R_2 picks up $y = 3a \cos \omega t$

$$\therefore \langle I_{R_2} \rangle = \frac{1}{2} 9a^2$$

Thus R_2 picks up larger signal compared to R_1 .

(iv) Thus a signal at R_1 indicates B has been switched off and an enhanced signal at R_2 indicates D has been switched off.

- 10.22** (i) Suppose the postulate is true, then two parallel rays would proceed as shown in Fig. 1. Assuming ED shows a wave front then all points on this must have the same phase. All points with the same optical path length must have the same phase.

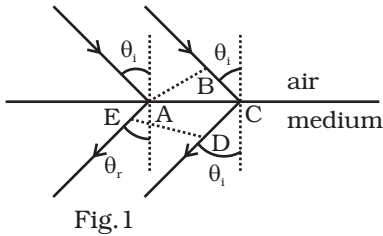

Fig. 1

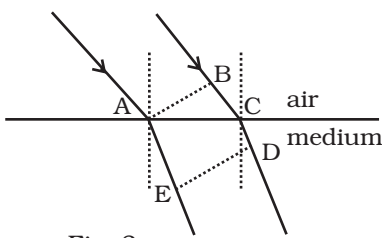

Fig. 2

$$\text{Thus } -\sqrt{\epsilon_r \mu_r} AE = BC - \sqrt{\epsilon_r \mu_r} CD$$

$$\text{or } BC = \sqrt{\epsilon_r \mu_r} (CD - AE)$$

$$BC > 0, CD > AE$$

As showing that the postulate is reasonable. If however, the light proceeded in the sense it does for ordinary material (viz. in the fourth quadrant, Fig. 2)

$$\text{Then } -\sqrt{\epsilon_r \mu_r} AE = BC - \sqrt{\epsilon_r \mu_r} CD$$

$$\text{or } BC = \sqrt{\epsilon_r \mu_r} (CD - AE)$$

$$\text{As } AE > CD, BC < 0$$

showing that this is not possible. Hence the postulate is correct.

- (ii) From Fig. 1.

$$BC = AC \sin \theta_i \text{ and } CD - AE = AC \sin \theta_r;$$

$$\text{Since } -\sqrt{\epsilon_r \mu_r} (AE - CD) = BC$$

$$-n \sin \theta_r = \sin \theta_i.$$

- 10.23** Consider a ray incident at an angle i . A part of this ray is reflected from the air-film interface and a part refracted inside. This is partly reflected at the film-glass interface and a part transmitted. A part of the reflected ray is reflected at the film-air interface and a part transmitted as r_2 parallel to r_1 . Of course successive reflections and transmissions will keep on decreasing the amplitude of the wave. Hence rays r_1 and r_2 shall dominate the behavior. If incident light is to be transmitted through the lens, r_1 and r_2 should interfere destructively. Both the reflections at A and D are from lower to higher refractive index and hence there is no phase change on reflection. The optical path difference between r_2 and r_1 is $n(AD + CD) - AB$.

If d is the thickness of the film, then

$$AD = CD = \frac{d}{\cos r}$$

$$AB = AC \sin i$$

$$\frac{AC}{2} = d \tan r$$

$$\therefore AC = 2d \tan r$$

$$\text{Hence, } AB = 2d \tan r \sin i$$

Thus the optical path difference is

$$2n \frac{d}{\cos r} - 2d \tan r \sin i$$

$$= 2 \cdot \frac{\sin i}{\sin r} \frac{d}{\cos r} - 2d \frac{\sin r}{\cos r} \sin i$$

$$= 2d \sin \left[\frac{1 - \sin^2 r}{\sin r \cos r} \right]$$

$$= 2nd \cos r$$

For these waves to interfere destructively this must be $\lambda/2$.

$$\Rightarrow 2nd \cos r = \frac{\lambda}{2}$$

$$\text{or } nd \cos r = \lambda/4$$

For a camera lens, the sources are in the vertical plane and hence

$$i \approx r \approx 0$$

$$\therefore nd = \frac{\lambda}{4}$$

$$\Rightarrow d = \frac{5500 \text{ \AA}}{1.38 \times 4} = 1000 \text{ \AA}$$

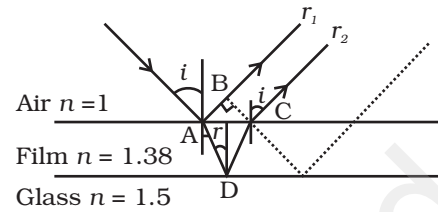

Chapter 11

11.1 (d)

11.2 (b)

11.3 (d)

11.4 (c)

11.5 (b)

11.6 (a)

11.7 (a)

11.8 (c)

11.9 (c), (d)

11.10 (a), (c)

11.11 (b), (c)

11.12 (a), (b), (c)

11.13 (b), (d)

$$11.14 \quad \lambda_p / \lambda_d = p_x / p_p = \frac{\sqrt{2m_\alpha E_\alpha}}{\sqrt{2m_p E_p}} = \sqrt{8} : 1$$

11.15 (i) $E_{\max} = 2h\nu - \phi$

(ii) The probability of absorbing 2 photons by the same electron is very low. Hence such emissions will be negligible.

11.16 In the first case energy given out is less than the energy supplied. In the second case, the material has to supply the energy as the emitted photon has more energy. This cannot happen for stable substances.

11.17 No, most electrons get scattered into the metal. Only a few come out of the surface of the metal.

11.18 Total E is constant

Let n_1 and n_2 be the number of photons of X-rays and visible region

$$n_1 E_1 = n_2 E_2$$

$$n_1 \frac{hc}{\lambda_1} = n_2 \frac{hc}{\lambda_2}$$

$$\frac{n_1}{n_2} = \frac{\lambda_1}{\lambda_2}$$

$$\frac{n_1}{n_2} = \frac{1}{500}$$

11.19 The momentum is transferred to the metal. At the microscopic level, atoms absorb the photon and its momentum is transferred mainly to the nucleus and electrons. The excited electron is emitted. Conservation of momentum needs to be accounted for the momentum transferred to the nucleus and electrons.

11.20 Maximum energy = $h\nu - \phi$

$$\left(\frac{1230}{600} - \phi \right) = \frac{1}{2} \left(\frac{1230}{400} - \phi \right)$$

$$\phi = \frac{1230}{1200} = 1.02 \text{ eV.}$$

11.21 $\Delta x \Delta p$; h

$$\Delta p$$
; $\frac{h}{\Delta x}$; $\frac{1.05 \times 10^{-34} \text{ Js}}{10^{-9} \text{ m}} = 1.05 \times 10^{-25}$

Exemplar Problems–Physics

$$E = \frac{p^2}{2m} = \frac{(1.05 \times 10^{-25})^2}{2 \times 9.1 \times 10^{-31}} = \frac{1.05^2}{18.2} \times 10^{-19} \text{ J} = \frac{1.05^2}{18.2 \times 1.6} eV$$

$$= 3.8 \times 10^{-2} eV$$

11.22 $I = n_A n_A = n_B v_B$

$$\frac{n_A}{n_B} = 2 = \frac{v_B}{v_A}$$

The frequency of beam B is twice that of A.

11.23 $p_c = |p_A| + |p_B| = \frac{h}{\lambda_A} + \frac{h}{\lambda_B} = \frac{h}{\lambda_c} = \frac{h}{\lambda_c}$ if $p_A, p_B > 0$ or $p_A, p_B < 0$

$$\text{or } \lambda_c = \frac{\lambda_A \lambda_B}{\lambda_A + \lambda_B}$$

If $p_A > 0, p_B < 0$ or $p_A < 0, p_B > 0$

$$p_c = h \frac{\lambda_B - \lambda_A}{|\lambda_A \lambda_B|} = \frac{h}{\lambda_c}$$

$$\lambda_c = \frac{\lambda_B \lambda_A}{|\lambda_A - \lambda_B|}$$

11.24 $2d \sin \theta = \lambda = d = 10^{-10} \text{ m.}$

$$p = \frac{h}{10^{-10}} = \frac{6.6 \times 10^{-34}}{10^{-10}} = 6.6 \times 10^{-21} \text{ kg m/s}$$

$$E = \frac{(6.6 \times 10^{-24})^2}{2 \times (1.7 \times 10^{-27})} \times 1.6 \times 10^{-19} = \frac{6.6^2}{2 \times 1.7} \times 1.6 \times 10^{-2} eV$$

$$= 20.5 \times 10^{-2} eV = 0.21 eV$$

11.25 6×10^{26} Na atoms weighs 23 kg.

Volume of target = $(10^{-4} \times 10^{-3}) = 10^{-7} \text{ m}^3$

Density of sodium = $(d) = 0.97 \text{ kg/m}^3$

$$\text{Volume of } 6 \times 10^{26} \text{ Na atoms} = \frac{23}{0.97} \text{ m}^3 = 23.7 \text{ m}^3$$

$$\text{Volume occupied of 1 Na atom} = \frac{23}{0.97 \times 6 \times 10^{26}} \text{ m}^3 = 3.95 \times 10^{-26} \text{ m}^3$$

$$\text{No. of sodium atoms in the target} = \frac{10^{-7}}{3.95 \times 10^{-26}} = 2.53 \times 10^{18}$$

Number of photons/s in the beam for $10^{-4} \text{ m}^2 = n$

$$\text{Energy per s } nh\nu = 10^{-4} \text{ J} \times 100 = 10^{-2} \text{ W}$$

$$h\nu \text{ (for } \lambda = 660\text{nm)} = \frac{1234.5}{600}$$

$$= 2.05\text{eV} = 2.05 \times 1.6 \times 10^{-19} = 3.28 \times 10^{-19}\text{J.}$$

$$n = \frac{10^{-2}}{3.28 \times 10^{-19}} = 3.05 \times 10^{16} / \text{s}$$

$$n = \frac{1}{3.2} \times 10^{17} = 3.1 \times 10^{16}$$

If P is the probability of emission per atom, per photon, the number of photoelectrons emitted/second

$$= P \times 3.1 \times 10^{16} \times 2.53 \times 10^{18}$$

$$\text{Current} = P \times 3.1 \times 10^{16} \times 2.53 \times 10^{18} \times 1.6 \times 10^{-19} \text{ A}$$

$$= P \times 1.25 \times 10^{16} \text{ A}$$

This must equal $100\mu\text{A}$ or

$$P = \frac{100 \times 10^{-6}}{1.25 \times 10^{16}}$$

$$\therefore P = 8 \times 10^{-21}$$

Thus the probability of photomission by a single photon on a single atom is very much less than 1. (That is why absorption of two photons by an atom is negligible).

$$\mathbf{11.26} \quad \text{Work done by an external agency} = + \frac{1}{4\pi\epsilon_0} \cdot \frac{1}{4} \int_d^\infty \frac{q^2}{x^2} dx = \frac{1}{4} \cdot \frac{q^2}{4\pi\epsilon_0 d}$$

$$\text{With } d = 0.1\text{nm, energy} = \frac{(1.6 \times 10^{-19}) \times 9 \times 10^9}{4(10^{-10}) \times 1.6 \times 10^{-19}} \text{ eV}$$

$$= \frac{1.6 \times 9}{4} \text{ eV} = 3.6 \text{ eV}$$

11.27 (i) Stopping potential = 0 at a higher frequency for B. Hence it has a higher work function.

$$\text{(ii) Slope} = \frac{h}{e} = \frac{2}{(10-5) \times 10^{14}} \text{ for A.}$$

$$= \frac{2.5}{(15-10) \times 10^{14}} \text{ for B.}$$

Exemplar Problems–Physics

$$h = \frac{1.6 \times 10^{-19}}{5} \times 2 \times 10^{-14} = 6.04 \times 10^{-34} \text{ Js for A}$$

$$= \frac{1.6 \times 10^{-19} \times 2.5 \times 10^{-14}}{5} = 8 \times 10^{-34} \text{ Js for B.}$$

Since h works out differently, experiment is not consistent with the theory.

11.28 $m_A v = m_A v_1 + m_B v_2$

$$\frac{1}{2} m_A v^2 = \frac{1}{2} m_A v_1^2 + \frac{1}{2} m_B v_2^2$$

$$\therefore \frac{1}{2} m_A (v - v_1)(v + v_1) = \frac{1}{2} m_B v_2^2$$

$$\therefore v + v_1 = v_2$$

$$\text{or } v = v_2 - v_1$$

$$\therefore v_1 = \left(\frac{m_A - m_B}{m_A + m_B} \right) v, \quad \text{and} \quad v_2 = \left(\frac{2m_A}{m_A + m_B} \right) v$$

$$\therefore \lambda_{\text{initial}} = \frac{h}{m_A v}$$

$$\lambda_{\text{final}} = \frac{h}{m_A v} = \left| \frac{h(m_A + m_B)}{m_A(m_A - m_B)v} \right|$$

$$\therefore \Delta \lambda = \frac{h}{m_A v} \left[\left| \frac{m_A + m_B}{m_A - m_B} \right| - 1 \right]$$

11.29 (i) $\frac{dN}{dt} = \frac{P}{(hc/\lambda)} = 5 \times 10^{19} / \text{s}$

(ii) $\frac{hc}{\lambda} = 2.49 \text{ eV} > W_0$: Yes.

(iii) $P \cdot \frac{\pi r^2}{4\pi d^2} \Delta t = W_0$, $\Delta t = 28.4 \text{ s}$

(iv) $N = \left(\frac{dN}{dt} \right) \times \frac{\pi r^2}{4\pi d^2} \times \Delta t = 2$

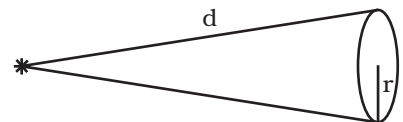

Chapter 12

- 12.1 (c)
- 12.2 (c)
- 12.3 (a)
- 12.4 (a)
- 12.5 (a)
- 12.6 (a)
- 12.7 (a)
- 12.8 (a), (c)
- 12.9 (a), (b)
- 12.10 (a), (b)
- 12.11 (b), (d)
- 12.12 (b), (d)
- 12.13 (c), (d)
- 12.14 Einstein's mass-energy equivalence gives $E = mc^2$. Thus the mass of a H-atom is $m_p + m_e - \frac{B}{c^2}$ where $B \approx 13.6\text{eV}$ is the binding energy.
- 12.15 Because both the nuclei are very heavy as compared to electron mass.
- 12.16 Because electrons interact only electromagnetically.
- 12.17 Yes, since the Bohr formula involves only the product of the charges.
- 12.18 No, because according to Bohr model, $E_n = -\frac{13.6}{n^2}$,
and electrons having different energies belong to different levels having different values of n . So, their angular momenta will be different, as $mvr = \frac{nh}{2\pi}$.
- 12.19 The ' m ' that occurs in the Bohr formula $E_n = -\frac{me^4}{8\epsilon_0 n^2 h^2}$ is the reduced mass. For H-atom $m \approx m_e$. For positronium $m \approx m_e / 2$. Hence for a positronium $E_1 \approx -6.8\text{eV}$.

Exemplar Problems–Physics

- 12.20** For a nucleus with charge $2e$ and electrons of charge $-e$, the levels are $E_n = -\frac{4me^4}{8\epsilon_0^2 n^2 h^2}$. The ground state will have two electrons each of energy E , and the total ground state energy would be $-(4 \times 13.6) \text{ eV}$.

- 12.21** v = velocity of electron

$$a_0 = \text{Bohr radius.}$$

$$\therefore \text{Number of revolutions per unit time} = \frac{2\pi a_0}{v}$$

$$\therefore \text{Current} = \frac{2\pi a_0}{v} e.$$

12.22
$$v_{mn} = cRZ^2 \left[\frac{1}{(n+p)^2} - \frac{1}{n^2} \right],$$

where $m = n + p$, ($p = 1, 2, 3, \dots$) and R is Rydberg constant.

For $p \ll n$.

$$v_{mn} = cRZ^2 \left[\frac{1}{n^2} \left(1 + \frac{p}{n} \right)^{-2} - \frac{1}{n^2} \right]$$

$$v_{mn} = cRZ^2 \left[\frac{1}{n^2} - \frac{2p}{n^3} - \frac{1}{n^2} \right]$$

$$v_{mn} = cRZ^2 \frac{2p}{n^3}; \left(\frac{2cRZ^2}{n^3} \right) p$$

Thus, v_{mn} are approximately in the order 1, 2, 3,.....

- 12.23** H_γ in Balmer series corresponds to transition $n = 5$ to $n = 2$. So the electron in ground state $n = 1$ must first be put in state $n = 5$. Energy required = $E_1 - E_5 = 13.6 - 0.54 = 13.06 \text{ eV}$.

If angular momentum is conserved, angular momentum of photon = change in angular momentum of electron

$$= L_5 - L_2 = 5h - 2h = 3h = 3 \times 1.06 \times 10^{-34}$$

$$= 3.18 \times 10^{-34} \text{ kg m}^2/\text{s}.$$

- 12.24** Reduced mass for $H = \mu_H = \frac{m_e}{1 + \frac{m_e}{M}}; m_e \left(1 - \frac{m_e}{M} \right)$

Reduced mass for $D = \mu_D$; $m_e \left(1 - \frac{m_e}{2M}\right) = m_e \left(1 - \frac{m_e}{2M}\right) \left(1 + \frac{m_e}{2M}\right)$

$$h\nu_{ij} = (E_i - E_j)\alpha\mu. \text{ Thus, } \lambda_{ij} \propto \frac{1}{\mu}$$

If for Hydrogen/Deuterium the wavelength is λ_H / λ_D

$$\frac{\lambda_D}{\lambda_H} = \frac{\mu_H}{\mu_D}; \left(1 + \frac{m_e}{2M}\right)^{-1}; \left(1 - \frac{1}{2 \times 1840}\right)$$

$$\lambda_D = \lambda_H \times (0.99973)$$

Thus lines are 1217.7 Å, 1027.7 Å, 974.04 Å, 951.143 Å.

12.25 Taking into account the nuclear motion, the stationary state energies shall be, $E_n = -\frac{\mu Z^2 e^4}{8\epsilon_0^2 h^2} \left(\frac{1}{n^2}\right)$. Let μ_H be the reduced mass

of Hydrogen and μ_D that of Deuterium. Then the frequency of the

1st Lyman line in Hydrogen is $h\nu_H = \frac{\mu_H e^4}{8\epsilon_0^2 h^2} \left(1 - \frac{1}{4}\right) = \frac{3}{4} \frac{\mu_H e^4}{8\epsilon_0^2 h^2}$. Thus

the wavelength of the transition is $\lambda_H = \frac{3}{4} \frac{\mu_H e^4}{8\epsilon_0^2 h^3 c}$. The wavelength

of the transition for the same line in Deuterium is $\lambda_D = \frac{3}{4} \frac{\mu_D e^4}{8\epsilon_0^2 h^3 c}$.

$$\therefore \Delta\lambda = \lambda_D - \lambda_H$$

Hence the percentage difference is

$$100 \times \frac{\Delta\lambda}{\lambda_H} = \frac{\lambda_D - \lambda_H}{\lambda_H} \times 100 = \frac{\mu_D - \mu_H}{\mu_H} \times 100$$

$$= \frac{\frac{m_e M_D}{(m_e + M_D)} - \frac{m_e M_H}{(m_e + M_H)}}{\frac{m_e M_H}{(m_e + M_H)}} \times 100$$

$$= \left[\left(\frac{m_e + M_H}{m_e + M_D} \right) \frac{M_D}{M_H} - 1 \right] \times 100$$

Since $m_e \ll M_H < M_D$

Exemplar Problems–Physics

$$\begin{aligned}
 \frac{\Delta\lambda}{\lambda_H} \times 100 &= \left[\frac{M_H}{M_D} \times \frac{M_D}{M_H} \left(\frac{1+m_e/M_H}{1+m_e/M_D} \right) - 1 \right] \times 100 \\
 &= \left[(1+m_e/M_H)(1+m_e/M_D)^{-1} - 1 \right] \times 100 \\
 &= \left[1 + \frac{m_e}{M_H} - \frac{m_e}{M_D} - 1 \right] \times 100 \\
 &\approx m_e \left[\frac{1}{M_H} - \frac{1}{M_D} \right] \times 100 \\
 &= 9.1 \times 10^{-31} \left[\frac{1}{1.6725 \times 10^{-27}} - \frac{1}{3.3374 \times 10^{-27}} \right] \times 100 \\
 &= 9.1 \times 10^{-4} [0.5979 - 0.2996] \times 100 \\
 &= 2.714 \times 10^{-2} \%
 \end{aligned}$$

12.26 For a point nucleus in H-atom:

$$\text{Ground state: } mvr = \hbar, \frac{mv^2}{r_B} = -\frac{e^2}{r_B^2} \cdot \frac{1}{4\pi\epsilon_0}$$

$$\therefore m \frac{\hbar^2}{m^2 r_B^2} \cdot \frac{1}{r_B} = + \left(\frac{e^2}{4\pi\epsilon_0} \right) \frac{1}{r_B^2}$$

$$\therefore \frac{\hbar^2}{m} \cdot \frac{4\pi\epsilon_0}{e^2} = r_B = 0.51 \text{ \AA}$$

Potential energy

$$-\left(\frac{e^2}{4\pi\epsilon_0} \right) \cdot \frac{1}{r_B} = -27.2 \text{ eV}; K.E = \frac{mv^2}{2} = \frac{1}{2} m \cdot \frac{\hbar^2}{m^2 r_B^2} = \frac{\hbar^2}{2m r_B^2} = +13.6 \text{ eV}$$

For an spherical nucleus of radius R ,

If $R < r_B$, same result.

If $R \gg r_B$: the electron moves inside the sphere with radius r'_B (r'_B = new Bohr radius).

$$\text{Charge inside } r'_B = e \left(\frac{r'_B{}^3}{R^3} \right)$$

$$\therefore r'_B = \frac{h^2}{m} \left(\frac{4\pi\epsilon_0}{e^2} \right) \frac{R^3}{r_B'^3}$$

$$r_B'^4 = (0.51 \text{ \AA}) \cdot R^3 \quad R = 10 \text{ \AA}$$

$$= 510(\text{ \AA})^4$$

$$\therefore r'_B \approx (510)^{1/4} \text{ \AA} < R.$$

$$K.E = \frac{1}{2} m v^2 = \frac{m}{2} \cdot \frac{h}{m^2 r_B'^2} = \frac{h}{2m} \cdot \frac{1}{r_B'^2}$$

$$= \left(\frac{h^2}{2m r_B'^2} \right) \cdot \left(\frac{r_B'^2}{r_B'^2} \right) = (13.6 \text{ eV}) \frac{(0.51)^2}{(510)^{1/2}} = \frac{3.54}{22.6} = 0.16 \text{ eV}$$

$$P.E = + \left(\frac{e^2}{4\pi\epsilon_0} \right) \cdot \left(\frac{r_B'^2 - 3R^2}{2R^3} \right)$$

$$= + \left(\frac{e^2}{4\pi\epsilon_0} \cdot \frac{1}{r_B} \right) \cdot \left(\frac{r_B (r_B'^2 - 3R^2)}{R^3} \right)$$

$$= +(27.2 \text{ eV}) \left[\frac{0.51(\sqrt{510} - 300)}{1000} \right]$$

$$= +(27.2 \text{ eV}) \cdot \frac{-141}{1000} = -3.83 \text{ eV}.$$

12.27 As the nucleus is massive, recoil momentum of the atom may be neglected and the entire energy of the transition may be considered transferred to the Auger electron. As there is a single valence electron in Cr, the energy states may be thought of as given by the Bohr model.

The energy of the n th state $E_n = -Z^2 R \frac{1}{n^2}$ where R is the Rydberg constant and $Z = 24$.

The energy released in a transition from 2 to 1 is $\Delta E = Z^2 R \left(1 - \frac{1}{4} \right) = \frac{3}{4} Z^2 R$. The energy required to eject a $n = 4$

electron is $E_4 = Z^2 R \frac{1}{16}$.

Exemplar Problems–Physics

Thus the kinetic energy of the Auger electron is

$$\begin{aligned}
 K.E &= Z^2 R \left(\frac{3}{4} - \frac{1}{16} \right) = \frac{1}{16} Z^2 R \\
 &= \frac{11}{16} \times 24 \times 24 \times 13.6 \text{ eV} \\
 &= 5385.6 \text{ eV}
 \end{aligned}$$

12.28 $m_p c^2 = 10^{-6} \times \text{electron mass} \times c^2$

$$\approx 10^{-6} \times 0.5 \text{ MeV}$$

$$\approx 10^{-6} \times 0.5 \times 1.6 \times 10^{-13}$$

$$\approx 0.8 \times 10^{-19} \text{ J}$$

$$\frac{h}{m_p c} = \frac{hc}{m_p c^2} = \frac{10^{-34} \times 3 \times 10^8}{0.8 \times 10^{-19}} \approx 4 \times 10^{-7} \text{ m} \gg \text{Bohr radius.}$$

$$|\mathbf{F}| = \frac{e^2}{4\pi\epsilon_0} \left[\frac{1}{r^2} + \frac{\lambda}{r} \right] \exp(-\lambda r)$$

where $\lambda^{-1} = \frac{\hbar}{m_p c} \approx 4 \times 10^{-7} \text{ m} \gg r_B$

$$\therefore \lambda \ll \frac{1}{r_B} \text{ i.e. } \lambda r_B \ll 1$$

$$U(r) = -\frac{e^2}{4\pi\epsilon_0} \cdot \frac{\exp(-\lambda r)}{r}$$

$$mvr = h \therefore v = \frac{h}{mr}$$

$$\text{Also: } \frac{mv^2}{r} \approx \left(\frac{e^2}{4\pi\epsilon_0} \right) \left[\frac{1}{r^2} + \frac{\lambda}{r} \right]$$

$$\therefore \frac{h^2}{mr^3} = \left(\frac{e^2}{4\pi\epsilon_0} \right) \left[\frac{1}{r^2} + \frac{\lambda}{r} \right]$$

$$\therefore \frac{h^2}{m} = \left(\frac{e^2}{4\pi\epsilon_0} \right) [r + \lambda r^2]$$

$$\text{If } \lambda = 0; r = r_B = \frac{h}{m} \cdot \frac{4\pi\epsilon_0}{e^2}$$

$$\frac{h^2}{m} = \frac{e^2}{4\pi\epsilon_0} \cdot r_B$$

Since $\lambda^{-1} \gg r_B$, put $r = r_B + \delta$

$$\therefore r_B = r_B + \delta + \lambda(r_B^2 + \delta^2 + 2\delta r_B); \text{ neglect } \delta^2$$

$$\text{or } 0 = \lambda r_B^2 + \delta(1 + 2\lambda r_B)$$

$$\delta = \frac{-\lambda r_B^2}{1 + 2\lambda r_B} \approx \lambda r_B^2 (1 - 2\lambda r_B) = -\lambda r_B^2 \text{ since } \lambda r_B \ll 1$$

$$\therefore V(r) = -\frac{e^2}{4\pi\epsilon_0} \cdot \frac{\exp(-\lambda\delta - \lambda r_B)}{r_B + \delta}$$

$$\therefore V(r) = -\frac{e^2}{4\pi\epsilon_0} \frac{1}{r_B} \left[\left(1 - \frac{\delta}{r_B}\right) \cdot (1 - \lambda r_B) \right]$$

$\cong (-27.2\text{eV})$ remains unchanged.

$$K.E = -\frac{1}{2} m v^2 = \frac{1}{2} m \cdot \frac{h^2}{m r^2} = \frac{h^2}{2(r_B + \delta)^2} = \frac{h^2}{2r_B^2} \left(1 - \frac{2\delta}{r_B}\right)$$

$$= (13.6\text{eV}) [1 + 2\lambda r_B]$$

$$\text{Total energy} = -\frac{e^2}{4\pi\epsilon_0 r_B} + \frac{h^2}{2r_B^2} [1 + 2\lambda r_B]$$

$$= -27.2 + 13.6 [1 + 2\lambda r_B] \text{eV}$$

$$\text{Change in energy} = 13.6 \times 2\lambda r_B \text{eV} = 27.2\lambda r_B \text{eV}$$

12.29 Let $\epsilon = 2 + \delta$

$$F = \frac{q_1 q_2}{4\pi\epsilon_0} \cdot \frac{R_0^\delta}{r^{2+\delta}} = \wedge \frac{R_0^\delta}{r^{2+\delta}}, \text{ where } \frac{q_1 q_2}{4\pi_0 \epsilon} = \wedge, \wedge = (1.6 \times 10^{-19})^2 \times 9 \times 10^9$$

$$= 23.04 \times 10^{-29}$$

$$= \frac{mv^2}{r}$$

$$v^2 = \frac{\wedge R_0^\delta}{mr^{1+\delta}}$$

$$(i) \quad mvr = nh, \quad r = \frac{nh}{mv} = \frac{nh}{m} \left[\frac{m}{\wedge R_0^\delta} \right]^{1/2} r^{1/2+\delta/2}$$

$$\text{Solving this for } r, \text{ we get } r_n = \left[\frac{n^2 \hbar^2}{m \wedge R_0^\delta} \right]^{1/3}$$

For $n = 1$ and substituting the values of constant, we get

$$r_1 = \left[\frac{\hbar^2}{m \wedge R_0^\delta} \right]^{1/3}$$

$$r_1 = \left[\frac{1.05^2 \times 10^{-68}}{9.1 \times 10^{-31} \times 2.3 \times 10^{-28} \times 10^{19}} \right]^{1/3} = 8 \times 10^{-11} = 0.08 \text{ nm}$$

(< 0.1 nm)

$$(ii) \quad v_n = \frac{n\hbar}{mr_n} = n\hbar \left(\frac{m \wedge R_0^\delta}{n^2 \hbar^2} \right)^{1/3}. \text{ For } n = 1, v_1 = \frac{\hbar}{mr_1} = 1.44 \times 10^6 \text{ m/s}$$

$$(iii) \quad \text{K.E.} = \frac{1}{2} mv_1^2 = 9.43 \times 10^{-19} \text{ J} = 5.9 \text{ eV}$$

$$\text{P.E. till } R_0 = -\frac{\wedge}{R_0}$$

$$\text{P.E. from } R_0 \text{ to } r = +\wedge R_0^\delta \int_{R_0}^r \frac{dr}{r^{2+\delta}} = +\frac{\wedge R_0^\delta}{-1-\delta} \left[\frac{1}{r^{1+\delta}} \right]_{R_0}^r$$

$$= -\frac{\wedge R_0^\delta}{1+\delta} \left[\frac{1}{r^{1+\delta}} - \frac{1}{R_0^{1+\delta}} \right]$$

$$= -\frac{\wedge}{1+\delta} \left[\frac{R_0^\delta}{r^{1+\delta}} - \frac{1}{R_0} \right]$$

$$\text{P.E.} = -\frac{\wedge}{1+\delta} \left[\frac{R_0^\delta}{r^{1+\delta}} - \frac{1}{R_0} + \frac{1+\delta}{R_0} \right]$$

$$P.E. = -\frac{\wedge}{-0.9} \left[\frac{R_0^{-1.9}}{r^{-0.9}} - \frac{1.9}{R_0} \right]$$

$$= \frac{2.3}{0.9} \times 10^{-18} [(0.8)^{0.9} - 1.9] \text{ J} = -17.3 \text{ eV}$$

Total energy is $(-17.3 + 5.9) = -11.4 \text{ eV}$.

Chapter 13

- 13.1** (c)
13.2 (b)
13.3 (b)
13.4 (a)
13.5 (a)
13.6 (b)
13.7 (b)
13.8 (a), (b)
13.9 (b), (d)
13.10 (c), (d)
13.11 No, the binding energy of H_1^3 is greater.

13.12

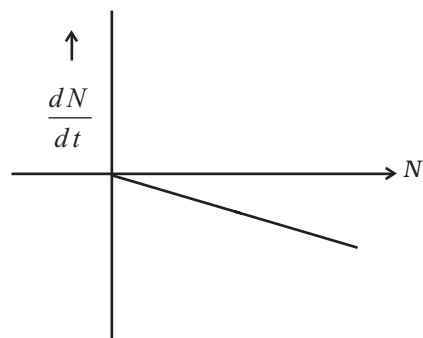

- 13.13** B has shorter mean life as λ is greater for B.
13.14 Excited electron because energy of electronic energy levels is in the range of eV, only not in MeV. as γ -radiation has energy in MeV.

Exemplar Problems–Physics

13.15 2γ photons are produced which move in opposite directions to conserve momentum.

13.16 Protons are positively charged and repel one another electrically. This repulsion becomes so great in nuclei with more than 10 protons or so, that an excess of neutrons which produce only attractive forces, is required for stability.

13.17

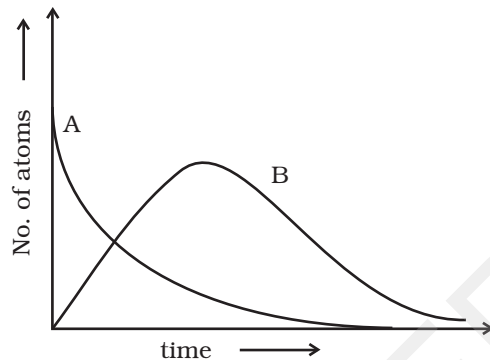

At $t = 0$, $N_A = N_0$ while $N_B = 0$. As time increases, N_A falls off exponentially, the number of atoms of B increases, becomes maximum and finally decays to zero at ∞ (following exponential decay law).

13.18

$$t = \frac{1}{\lambda} \ln \frac{R_0}{R}$$

$$= \frac{5760}{0.693} \ln \frac{16}{12} = \frac{5760}{0.693} \ln \frac{4}{3}$$

$$= \frac{5760}{0.693} \times 2.303 \log \frac{4}{3} = 2391.12 \text{ years.}$$

13.19 To resolve two objects separated by distance d , the wavelength λ of the probing signal must be less than d . Therefore, to detect separate parts inside a nucleon, the electron must have a wavelength less than 10^{-15} m.

$$\lambda = \frac{h}{p} \text{ and } K \approx pc \Rightarrow K \approx pc = \frac{hc}{\lambda}$$

$$= \frac{6.63 \times 10^{-34} \times 3 \times 10^8}{1.6 \times 10^{-19} \times 10^{-15}} \text{ eV}$$

$$= 10^9 \text{ eV.} = 1 \text{ GeV.}$$

13.20 (a) ${}_{11}^{23}\text{Na}$: $Z_1 = 11$, $N_1 = 12$

\therefore Mirror isobar of ${}_{11}^{23}\text{Na} = {}_{12}^{23}\text{Mg}$.

(b) Since $Z_2 > Z_1$, Mg has greater binding energy than Na.

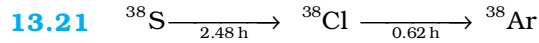

At time t , Let ^{38}S have $N_1(t)$ active nuclei and ^{38}Cl have $N_2(t)$ active nuclei.

$$\frac{dN_1}{dt} = -\lambda_1 N_1 = \text{rate of formation of Cl}^{38}. \text{ Also}$$

$$\frac{dN_2}{dt} = -\lambda_2 N_2 + \lambda_1 N_1$$

$$\text{But } N_1 = N_0 e^{-\lambda_1 t}$$

$$\frac{dN_2}{dt} = -\lambda_2 N_0 e^{-\lambda_1 t} - \lambda_2 N_2$$

Multiplying by $e^{\lambda_2 t} dt$ and rearranging

$$e^{\lambda_2 t} dN_2 + \lambda_2 N_2 e^{\lambda_2 t} dt = \lambda_1 N_0 e^{(\lambda_2 - \lambda_1)t} dt$$

Integrating both sides.

$$N_2 e^{\lambda_2 t} = \frac{N_0 \lambda_1}{\lambda_2 - \lambda_1} e^{(\lambda_2 - \lambda_1)t} + C$$

$$\text{Since at } t = 0, N_2 = 0, C = -\frac{N_0 \lambda_1}{\lambda_2 - \lambda_1}$$

$$\therefore N_2 e^{\lambda_2 t} = \frac{N_0 \lambda_1}{\lambda_2 - \lambda_1} (e^{(\lambda_2 - \lambda_1)t} - 1)$$

$$N_2 = \frac{N_0 \lambda_1}{\lambda_2 - \lambda_1} (e^{-\lambda_1 t} - e^{-\lambda_2 t})$$

$$\text{For maximum count, } \frac{dN_2}{dt} = 0$$

$$\text{On solving, } t = \left(\ln \frac{\lambda_1}{\lambda_2} \right) / (\lambda_1 - \lambda_2)$$

$$= \ln \frac{2.48}{0.62} / (2.48 - 0.62)$$

$$= \frac{\ln 4}{1.86} = \frac{2.303 \log 4}{1.86}$$

$$= 0.745 \text{ s.}$$

13.22 From conservation of energy

$$E - B = K_n + K_p = \frac{p_n^2}{2m} + \frac{p_p^2}{2m} \quad (1)$$

Exemplar Problems–Physics

From conservation of momentum

$$p_n + p_p = \frac{E}{c} \quad (2)$$

If $E = B$, the first equation gives $p_n = p_p = 0$ and hence the second equation cannot be satisfied, and the process cannot take place.

For the process to take place, Let $E = B + \lambda$, where λ would be $\ll B$.

Then : substituting for p_n from Equation (2) into Equation (1),

$$\lambda = \frac{1}{2m}(p_p^2 + p_n^2) = \frac{1}{2m}(p_p^2 + (p_p - E/c)^2)$$

$$\therefore 2p_p^2 - \frac{2E}{c}p_p + \left(\frac{E^2}{c^2} - 2m\lambda\right) = 0$$

$$\therefore p_p = \frac{2E/c \pm \sqrt{4E^2/c^2 - 8\left(\frac{E^2}{c^2} - 2m\lambda\right)}}{4}$$

Since the determinant must be positive for p_p to be real :

$$\frac{4E^2}{c^2} - 8\left(\frac{E^2}{c^2} - 2m\lambda\right) = 0$$

$$\text{Or, } 16m\lambda = \frac{4E^2}{c^2}, \therefore \lambda = \frac{E^2}{4mc^2} \approx \frac{B^2}{4mc^2}.$$

13.23 The binding energy in H atom $E = \frac{me^4}{8\epsilon_0^2 h^2} = 13.6 \text{ eV}$. (1)

If proton and neutron had charge e' each and were governed by the same electrostatic force, then in the above equation we would need to replace electronic mass m by the reduced mass m' of proton-neutron and the electronic charge e by e' .

$$m' = \frac{M}{2} = \frac{1836m}{2} = 918m.$$

$$\therefore \text{Binding energy} = \frac{918m e'^2}{8\epsilon_0^2 h^2} = 2.2 \text{ MeV} \quad (\text{given}) \quad (2)$$

Dividing (2) by (1)

$$918 \left(\frac{e'}{e} \right)^4 = \frac{2.2 \text{ MeV}}{13.6 \text{ eV}}$$

$$\Rightarrow \frac{e'}{e} \approx 11.$$

13.24 Before β decay, neutron is at rest. Hence $E_n = m_n c^2$, $p_n = 0$

After β decay, from conservation of momentum:

$$\mathbf{p}_n = \mathbf{p}_p + \mathbf{p}_e$$

$$\text{Or } \mathbf{p}_p + \mathbf{p}_e = 0 \Rightarrow |\mathbf{p}_p| = |\mathbf{p}_e| = p$$

$$\text{Also, } E_p = (m_p^2 c^4 + p^2 c^2)^{\frac{1}{2}},$$

$$E_e = (m_e^2 c^4 + p^2 c^2)^{\frac{1}{2}} = (m_e^2 c^4 + p_p^2 c^2)^{\frac{1}{2}}$$

From conservation of energy:

$$(m_p^2 c^4 + p^2 c^2)^{\frac{1}{2}} + (m_e^2 c^4 + p^2 c^2)^{\frac{1}{2}} = m_n c^2$$

$$m_p c^2 \approx 936 \text{ MeV}, m_n c^2 \approx 938 \text{ MeV}, m_e c^2 = 0.51 \text{ MeV}$$

Since the energy difference between n and p is small, pc will be small, $pc \ll m_p c^2$, while pc may be greater than $m_e c^2$.

$$\Rightarrow m_p c^2 + \frac{p^2 c^2}{2m_p^2 c^4}; m_n c^2 - pc$$

$$\text{To first order } pc; m_n c^2 - m_p c^2 = 938 \text{ MeV} - 936 \text{ MeV} = 2 \text{ MeV}$$

This gives the momentum.

Then,

$$E_p = (m_p^2 c^4 + p^2 c^2)^{\frac{1}{2}} = \sqrt{936^2 + 2^2}; 936 \text{ MeV}$$

$$E_e = (m_e^2 c^4 + p^2 c^2)^{\frac{1}{2}} = \sqrt{(0.51)^2 + 2^2}; 2.06 \text{ MeV}$$

13.25 (i) $t_{1/2} = 40$ min (approx).

(ii) Slope of graph = $-\lambda$

$$\text{So } \lambda = -\left(\frac{-4.16+3.11}{1}\right) = 1.05\text{h}$$

$$\text{So } t_{1/2} = \frac{0.693}{1.05} = 0.66\text{h} = 39.6 \text{ min or } 40 \text{ min (approx).}$$

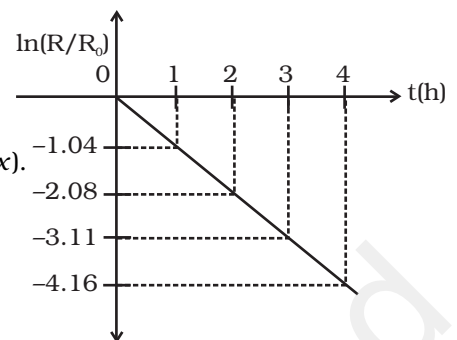

13.26 (i) $S_{pSn} = (M_{119,70} + M_H - M_{120,70})c^2$
 $= (118.9058 + 1.0078252 - 119.902199)c^2$
 $= 0.0114362 c^2$

$$S_{pSb} = (M_{120,70} + M_H - M_{121,70})c^2$$

$$= (119.902199 + 1.0078252 - 120.903822)c^2$$

$$= 0.0059912 c^2$$

Since $S_{pSn} > S_{pSb}$, Sn nucleus is more stable than Sb nucleus.

- (ii) It indicates shell structure of nucleus similar to the shell structure of an atom. This also explains the peaks in BE/nucleon curve.

Chapter 14

14.1 (d)

14.2 (b)

14.3 (b)

14.4 (d)

14.5 (b)

14.6 (c)

14.7 (b)

14.8 (c)

14.9 (a), (c)

14.10 (a), (c)

14.11 (b), (c), (d)

14.12 (b), (c)

14.13 (a), (b), (d)

14.14 (b), (d)

14.15 (a), (c), (d)

14.16 (a), (d)

14.17 The size of dopant atoms should be such as not to distort the pure semiconductor lattice structure and yet easily contribute a charge carrier on forming co-valent bonds with Si or Ge.

14.18 The energy gap for Sn is 0 eV, for C is 5.4 eV, for Si is 1.1 eV and for Ge is 0.7eV, related to their atomic size.

14.19 No, because the voltmeter must have a resistance very high compared to the junction resistance, the latter being nearly infinite.

14.20

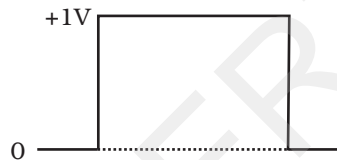

14.21 (i) $10 \times 20 \times 30 \times 10^{-3} = 6V$

(ii) If dc supply voltage is 5V, the output peak will not exceed $V_{cc} = 5V$. Hence, $V_o = 5V$.

14.22 No, the extra power required for amplified output is obtained from the DC source.

14.23 (i) ZENER junction diode and solar cell.

(ii) Zener breakdown voltage

(iii) Q- short circuit current

P- open circuit voltage.

14.24 Energy of incident light photon

$$h\nu = \frac{6.6 \times 10^{-34} \times 3 \times 10^8}{6 \times 10^{-7} \times 1.6 \times 10^{-19}} = 2.06eV$$

For the incident radiation to be detected by the photodiode, energy of incident radiation photon should be greater than the band gap. This is true only for D2. Therefore, only D2 will detect this radiation.

14.25 $I_B = \frac{V_{BB} - V_{BE}}{R_1}$. If R_1 is increased, I_B will decrease. Since $I_c = \beta I_b$, it will result in decrease in I_c i.e decrease in ammeter and voltmeter readings.

14.26

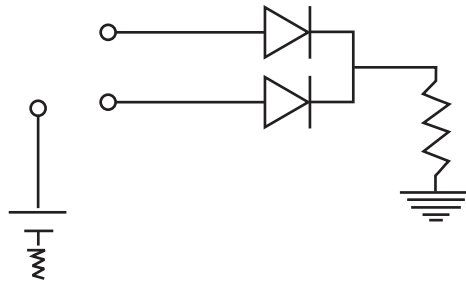

OR gate gives output according to the truth table.

A	B	C
0	0	0
0	1	1
1	0	1
1	1	1

14.27

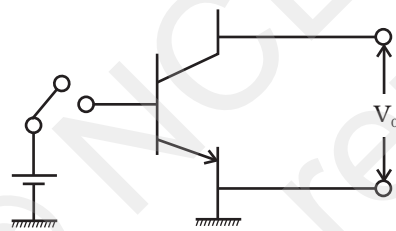

Input	Output
A	A
0	1
1	0

14.28 Elemental semiconductor's band-gap is such that emissions are in IR region.

14.29 Truth table

A	B	Y
0	0	0
0	1	0
1	0	0
1	1	1

AND Gate

14.30 $I_{Z\max} = \frac{P}{V_Z} = 0.2\text{A} = 200\text{mA}$

$$R_S = \frac{V_s - V_Z}{I_{Z\max}} = \frac{2}{0.2} = 10\Omega.$$

14.31 I_3 is zero as the diode in that branch is reverse biased. Resistance in the branch AB and EF are each $(125 + 25)\Omega = 150\Omega$.

As AB and EF are identical parallel branches, their effective resistance is $\frac{150}{2} = 75\Omega$

\therefore Net resistance in the circuit = $(75 + 25)\Omega = 100\Omega$.

$$\therefore \text{Current } I_1 = \frac{5}{100} = 0.05\text{A}.$$

As resistances of AB and EF are equal, and $I_1 = I_2 + I_3 + I_4$, $I_3 = 0$

$$\therefore I_2 = I_4 = \frac{0.05}{2} = 0.025\text{A}$$

14.32 As $V_{be} = 0$, potential drop across R_b is 10V.

$$\therefore I_b = \frac{10}{400 \times 10^3} = 25\mu\text{A}$$

Since $V_{ce} = 0$, potential drop across R_c , i.e. $I_c R_c$ is 10V.

$$\therefore I_c = \frac{10}{3 \times 10^3} = 3.33 \times 10^{-3} = 3.33\text{mA}.$$

$$\therefore \beta = \frac{I_c}{I_b} = \frac{3.33 \times 10^{-3}}{25 \times 10^{-6}} = 1.33 \times 10^2 = 133.$$

14.33

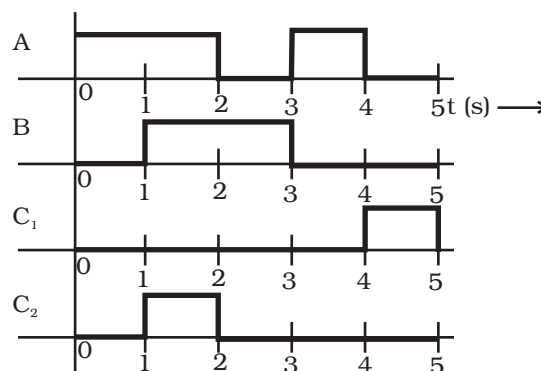

Exemplar Problems–Physics

14.34 From the output characteristics at point Q, $V_{CE} = 8V$ & $I_C = 4mA$

$$V_{CC} = I_C R_C + V_{CE}$$

$$R_C = \frac{V_{CC} - V_{CE}}{I_C}$$

$$R_C = \frac{16 - 8}{4 \times 10^{-3}} = 2K\Omega$$

Since,

$$V_{BB} = I_B R_B + V_{BE}$$

$$R_B = \frac{16 - 0.7}{30 \times 10^{-6}} = 510K\Omega$$

$$\text{Now, } \beta = \frac{I_C}{I_B} = \frac{4 \times 10^{-3}}{30 \times 10^{-6}} = 133$$

$$\begin{aligned} \text{Voltage gain} = A_V &= -\beta \frac{R_C}{R_B} \\ &= -133 \times \frac{2 \times 10^3}{510 \times 10^3} \\ &= 0.52 \end{aligned}$$

$$\text{Power Gain} = A_p = \beta \times A_V$$

$$= -\beta^2 \frac{R_C}{R_B}$$

$$= (133)^2 \times \frac{2 \times 10^3}{510 \times 10^3} = 69$$

14.35 When input voltage is greater than 5V, diode is conducting

When input is less than 5V, diode is open circuit

14.36 (i) In 'n' region; number of e^- is due to As:

$$n_e = N_D = 1 \times 10^{-6} \times 5 \times 10^{28} \text{ atoms/m}^3$$

$$n_e = 5 \times 10^{22}/\text{m}^3$$

The minority carriers (hole) is

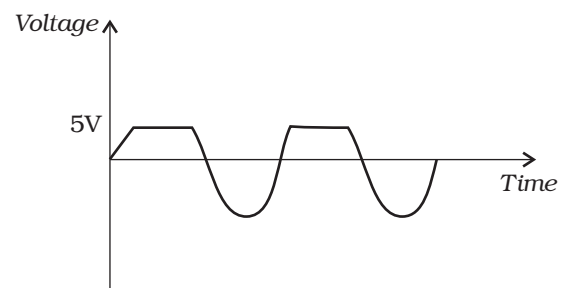

$$n_h = \frac{n_i^2}{n_e} = \frac{(1.5 \times 10^{16})^2}{5 \times 10^{22}} = \frac{2.25 \times 10^{32}}{5 \times 10^{22}}$$

$$n_h = 0.45 \times 10^{10}/\text{m}^3$$

Similarly, when Boron is implanted a 'p' type is created with holes

$$\begin{aligned} n_h &= N_A = 200 \times 10^{-6} \times 5 \times 10^{28} \\ &= 1 \times 10^{25}/\text{m}^3 \end{aligned}$$

This is far greater than e^- that existed in 'n' type wafer on which Boron was diffused.

Therefore, minority carriers in created 'p' region

$$\begin{aligned} n_e &= \frac{n_i^2}{n_h} = \frac{2.25 \times 10^{32}}{1 \times 10^{25}} \\ &= 2.25 \times 10^7/\text{m}^3 \end{aligned}$$

(ii) Thus, when reverse biased $0.45 \times 10^{10}/\text{m}^3$, holes of 'n' region would contribute more to the reverse saturation current than $2.25 \times 10^7/\text{m}^3$ minority e^- of p type region.

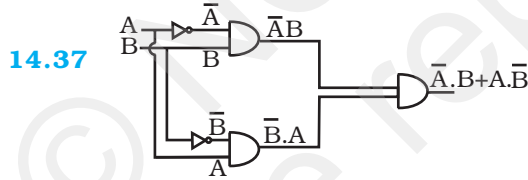

14.38

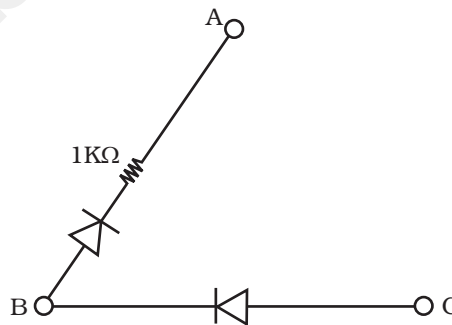

14.39 $I_C \approx I_E \therefore I_C(R_C + R_E) + V_{CE} = 12 \text{ V}$

$$R_E = 9 - R_C = 1.2 \text{ K}\Omega$$

Exemplar Problems–Physics

$$\begin{aligned}\therefore V_E &= 1.2 \text{ V} \\ V_B &= V_E + V_{BE} = 1.7 \text{ V} \\ I &= \frac{V_B}{20\text{K}} = 0.085 \text{ mA}\end{aligned}$$

$$R_B = \frac{12-1.7}{I_C / \beta + 0.085} = \frac{10.3}{0.01+1.085} = 108 \text{ K}\Omega$$

$$14.40 \quad I_E = I_C + I_B \quad I_C = \beta I_B \quad (1)$$

$$I_C R_C + V_{CE} + I_E R_E = V_{CC} \quad (2)$$

$$R I_B + V_{BE} + I_E R_E = V_{CC} \quad (3)$$

From (3) $I_E \approx I_C = \beta I_B$

$$(R + \beta R_E) = V_{CC} - V_{BE}, \quad I_B = \frac{V_{CC} - V_{BE}}{R + \beta R_E} = \frac{11.5}{200} \text{ mA}$$

From (2)

$$R_C + R_E = \frac{V_{CC} - V_{CE}}{I_C} = \frac{V_{CC} - V_{CE}}{\beta I_B} = \frac{2}{11.5} (12 - 3) \text{ K}\Omega = 1.56 \text{ K}\Omega$$

$$R_C = 1.56 - 1 = 0.56 \text{ K}\Omega$$

Chapter 15

15.1 (b)

15.2 (a)

15.3 (b)

15.4 (a)

15.5 (b)

15.6 (c)

15.7 (b)

15.8 (b)

15.9 (c)

15.10 (a), (b), (d)

15.11 (b), (d)

15.12 (b), (c), (d)

15.13 (a), (b), (c)

15.14 (b), (d)

15.15 (i) analog

(ii) analog

(iii) digital

(iv) digital

15.16 No, signals of frequency greater than 30 MHz will not be reflected by the ionosphere, but will penetrate through the ionosphere.

15.17 The refractive index increases with increase in frequency which implies that for higher frequency waves, angle of refraction is less, i.e. bending is less. Hence, the condition of total internal reflection is attained after travelling larger distance (by 3MHz wave).

15.18 $A_c + A_m = 15$, $A_c - A_m = 3$

$$\therefore 2A_c = 18, 2A_m = 12$$

$$\therefore m = \frac{A_m}{A_c} = \frac{2}{3}$$

15.19 $\frac{1}{2\pi\sqrt{LC}} = 1\text{MHz}$

$$\sqrt{LC} = \frac{1}{2\pi \times 10^6}$$

15.20 In AM, the carrier waves instantaneous voltage is varied by modulating waves voltage. On transmission, noise signals can also be added and receiver assumes noise a part of the modulating signal.

However in FM, the carriers frequency is changed as per modulating waves instantaneous voltage. This can only be done at the mixing/modulating stage and not while signal is transmitting in channel. Hence, noise doesn't effect FM signal.

15.21 Loss suffered in transmission path

$$= -2 \text{ dB km}^{-1} \times 5 \text{ km} = -10 \text{ dB}$$

$$\text{Total amplifier gain} = 10 \text{ dB} + 20 \text{ dB}$$

$$= 30 \text{ dB}$$

$$\text{Overall gain of signal} = 30 \text{ dB} - 10 \text{ dB}$$

$$= 20 \text{ dB}$$

Exemplar Problems–Physics

$$10 \log \left(\frac{P_o}{P_i} \right) = 12 \text{ or } P_o = P_i \times 10^2$$

$$= 1.01 \text{ mW} \times 100 = 101 \text{ mW.}$$

15.22 (i) Range = $\sqrt{2 \times 6.4 \times 10^6 \times 20} = 16 \text{ km}$

Area covered = 803.84 km^2

(ii) Range = $\sqrt{2 \times 6.4 \times 10^6 \times 20} + \sqrt{2 \times 6.4 \times 10^6 \times 25}$
 $= (16 + 17.9) \text{ km} = 33.9 \text{ km}$

Area covered = 3608.52 km^2

∴ Percentage increase in area

$$= \frac{(3608.52 - 803.84)}{803.84} \times 100$$

$$= 348.9\%$$

15.23 $d_m^2 = 2(R + h_T)^2$

$$8Rh_T = 2(R + h_T)^2 \quad (Q \ d_m = 2\sqrt{2Rh_T})$$

$$4Rh_T = R^2 + h_T^2 + 2Rh_T$$

$$(R - h_T)^2 = 0$$

$$R = h_T$$

Since space wave frequency is used, $\lambda \ll h_T$, hence only tower height is taken to consideration.

In three dimensions, 6 antenna towers of $h_T = R$ would do.

15.24 For F_1 layer

$$5 \times 10^6 = 9(N_{max})^{1/2} \text{ or } N_{max} = \left(\frac{5}{9} \times 10^6 \right)^2 = 3.086 \times 10^{11} \text{ m}^{-3}$$

For F_2 layer

$$8 \times 10^6 = 9(N_{max})^{1/2} \text{ or}$$

$$N_{max} = \left(\frac{8}{9} \times 10^6 \right)^2 = 7.9 \times 10^{11} \text{ m}^{-3} = 7.9 \times 10^{11} \text{ m}^{-3}.$$

15.25 Of $\omega_c - \omega_m$, ω_c and $\omega_m + \omega_m$, only $\omega_c + \omega_m$ or $\omega_c - \omega_m$ contains information. Hence cost can be reduced by transmitting $\omega_c + \omega_m$, $\omega_c - \omega_m$, both $\omega_c + \omega_m$ & $\omega_c - \omega_m$

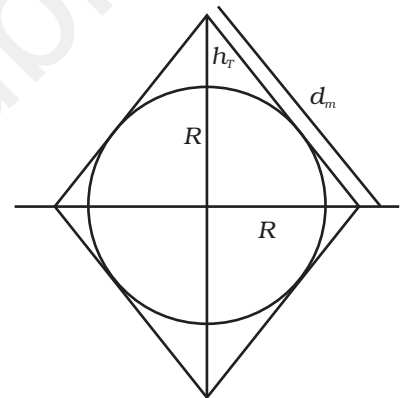

15.26 (i) $\frac{I}{I_o} = \frac{1}{4}$, so $\ln\left(\frac{1}{4}\right) = -\alpha x$

or $\ln 4 = \alpha x$ or $x = \left(\frac{\ln 4}{\alpha}\right)$

(ii) $10\log_{10} \frac{I}{I_o} = -\alpha x$ where α is the attenuation in dB/km.

Here $\frac{I}{I_o} = \frac{1}{2}$

or $10\log\left(\frac{1}{2}\right) = -50\alpha$ or $\log 2 = 5\alpha$

or $\alpha = \frac{\log 2}{5} = \frac{0.3010}{5} = 0.0602 \text{ dB/km}$

15.27 $\frac{2x}{\text{time}} = \text{velocity}$

$2x = 3 \times 10^8 \text{ m/s} \times 4.04 \times 10^{-3} \text{ s}$

$x = \frac{12.12 \times 10^5}{2} \text{ m} = 6.06 \times 10^5 \text{ m} = 606 \text{ km}$

$d^2 = x^2 - h_s^2 = (606)^2 - (600)^2 = 7236$; $d = 85.06 \text{ km}$

Distance between source and receiver = $2d \cong 170 \text{ km}$

$d_m = 2\sqrt{2Rh_T}$, $2d = d_m$, $4d^2 = 8Rh_T$

$\frac{d^2}{2R} = h_T = \frac{7236}{2 \times 6400} \approx 0.565 \text{ km} = 565 \text{ m}$.

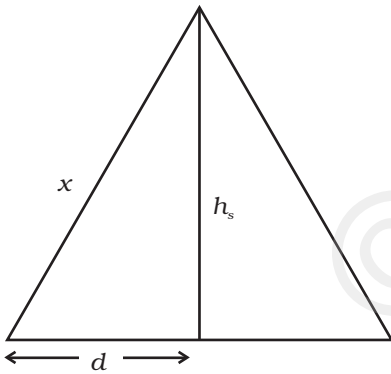

15.28 From the figure

$V_{max} = \frac{100}{2} = 50 \text{ V}$, $V_{min} = \frac{20}{2} = 10 \text{ V}$.

(i) Percentage modulation

$\mu(\%) = \frac{V_{max} - V_{min}}{V_{max} + V_{min}} \times 100 = \left(\frac{50 - 10}{50 + 10}\right) \times 100 = \frac{40}{60} \times 100 = 66.67\%$

(ii) Peak carrier voltage = $V_c = \frac{V_{max} + V_{min}}{2} = \frac{50 + 10}{2} = 30 \text{ V}$

(iii) Peak information voltage = $V_m = \mu V_c = \frac{2}{3} \times 30 = 20 \text{ V}$.

15.29 (a) $v(t) = A(A_{m_1} \sin \omega_{m_1} t + A_{m_2} \sin \omega_{m_2} t + A_c \sin \omega_c t)$

$$+ B(A_{m_1} \sin \omega_{m_1} t + A_{m_2} \sin \omega_{m_2} t + A_c \sin \omega_c t)^2$$

$$= A(A_{m_1} \sin \omega_{m_1} t + A_{m_2} \sin \omega_{m_2} t + A_c \sin \omega_c t)$$

$$+ B((A_{m_1} \sin \omega_{m_1} t + A_{m_2} t)^2 + A_c^2 \sin^2 \omega_c t$$

$$+ 2A_c(A_{m_1} \sin \omega_{m_1} t + A_{m_2} \sin \omega_c t))$$

$$= A(A_{m_1} \sin \omega_{m_1} t + A_{m_2} \sin \omega_{m_2} t + A_c \sin \omega_c t)$$

$$+ B[A_{m_1}^2 \sin^2 \omega_{m_1} t + A_{m_2}^2 \sin^2 \omega_{m_2} t + 2A_{m_1} A_{m_2} \sin \omega_{m_1} t \sin \omega_{m_2} t$$

$$+ A_c^2 \sin^2 \omega_c t + 2A_c(A_{m_1} \sin \omega_{m_1} t \sin \omega_c t + A_{m_2} \sin \omega_{m_2} t \sin \omega_c t)]$$

$$= A(A_{m_1} \sin \omega_{m_1} t + A_{m_2} \sin \omega_{m_2} t + A_c \sin \omega_c t)$$

$$+ B[A_{m_1}^2 \sin^2 \omega_{m_1} t + A_{m_2}^2 \sin^2 \omega_{m_2} t + A_c^2 \sin^2 \omega_c t$$

$$+ \frac{2A_{m_1} A_{m_2}}{2} [\cos(\omega_{m_2} - \omega_{m_1})t - \cos(\omega_{m_1} + \omega_{m_2})t]$$

$$+ \frac{2A_c A_{m_2}}{2} [\cos(\omega_c - \omega_{m_1})t - \cos(\omega_c + \omega_{m_1})t]$$

$$+ \frac{2A_c A_{m_1}}{2} [\cos(\omega_c - \omega_{m_2})t - \cos(\omega_c + \omega_{m_2})t]$$

∴ Frequencies present are

$$\omega_{m_1}, \omega_{m_2}, \omega_c$$

$$(\omega_{m_2} - \omega_{m_1}), (\omega_{m_1} + \omega_{m_2})$$

$$(\omega_c - \omega_{m_1}), (\omega_c + \omega_{m_1})$$

$$(\omega_c - \omega_{m_2}), (\omega_c + \omega_{m_2})$$

(i) Plot of amplitude versus ω is shown in the Figure.

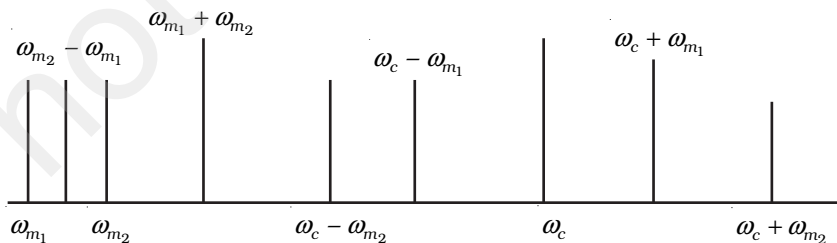

(ii) As can be seen frequency spectrum is not symmetrical about ω_c . Crowding of spectrum is present for $\omega < \omega_c$.

(iii) Adding more modulating signals lead to more crowding in $\omega < \omega_c$ and more chances of mixing of signals.

(iv) Increase band-width and ω_c to accommodate more signals. This shows that large carrier frequency enables to carry more information (more ω_m) and which will in turn increase band-width.

15.30 $f_m = 1.5\text{kHz}, \frac{1}{f_m} = 0.7 \times 10^{-3} \text{ s}$

$$f_c = 20\text{MHz}, \frac{1}{f_c} = 0.5 \times 10^{-7} \text{ s}$$

(i) $RC = 10^3 \times 10^{-8} = 10^{-5} \text{ s}$

So, $\frac{1}{f_c} \ll RC < \frac{1}{f_m}$ is satisfied

So it can be demodulated.

(ii) $RC = 10^4 \times 10^{-8} = 10^{-4} \text{ s}$.

Here too $\frac{1}{f_c} \ll RC < \frac{1}{f_m}$.

So this too can be demodulated

(iii) $RC = 10^4 \times 10^{-12} = 10^{-8} \text{ s}$.

Here $\frac{1}{f_c} > RC$, so this cannot be demodulated.

DESIGN OF QUESTION PAPER

PHYSICS CLASS XII

Time: Three Hours

Max. Marks: 70

The weightage of the distribution of marks over different dimensions of the question paper shall be as follows:

A. Weightage to content/subject units

Sl. No.	Unit	Marks
1.	Electrostatics	08
2.	Current Electricity	07
3.	Magnetic Effect of Current and Magnetism	08
4.	Electromagnetic Induction and Alternating Current	08
5.	Electromagnetic Waves	03
6.	Optics	14
7.	Dual Nature of Radiation and Matter	04
8.	Atoms and Nuclei	06
9.	Semiconductor Electronics	07
10.	Communication Systems	05
	Total	70

B. Weightage to form of questions

Sl. No.	Form of Questions	Marks for each Question	No. of Questions	Total Marks
1	Long Answer (LA)	5	3	15
2	Short Answer SA (I)	3	09	27
3	Short Answer SA (II)	2	10	20
4	Very Short Answer (VSA)	1	08	08
	Total	–	30	70

1Mark question may be Very Short Answer (VSA) type or Multiple Choice Question (MCQ) with only one option correct.

C. Scheme of options

1. There will be no overall option.
2. Internal choices (either or type) on a very selective basis has been given in some questions.

D. Weightage to difficulty levels of questions

Sl. No.	Estimated difficulty level	Percentage
1.	Easy	15
2.	Average	70
3.	Difficult	15

CLASS XII
PHYSICS
BLUE - PRINT I

Topic	VSA (1 mark)	SA II (2 marks)	SA I (3 Marks)	LA (5 marks)	Total
I Electrostatics	1 (1)	4 (2)	3 (1)	—	8 (4)
II Current Electricity	1 (1)	—	6 (2)	—	7 (3)
III Magnetic Effect of Current and Magnetism	1 (1)	2 (1)	—	5 (1)	8 (3)
IV Electromagnetic Induction and Alternating Current	1 (1)	2 (1)	—	5 (1)	8 (3)
V Electromagnetic Waves	1 (1)	2 (1)	—	—	3 (2)
VI Optics	—	—	9 (3)	5 (1)	14 (4)
VII Dual Nature of Radiation and Matter	—	4 (2)	—	—	4 (2)
VIII Atoms and Nuclei	1 (1)	2 (1)	3 (1)	—	6 (3)
IX Semiconductor Electronics	2 (2)	2 (1)	3 (1)	—	7 (4)
X Systems Communication	—	2 (1)	3 (1)	—	5 (2)
Total	8 (8)	20 (10)	27 (9)	15 (3)	70 (30)

SAMPLE PAPER I
XII - PHYSICS

Time : Three Hours

Max. Marks : 70

General Instructions

- (a) All questions are compulsory.
- (b) There are 30 questions in total. Questions 1 to 8 carry one mark each, questions 9 to 18 carry two marks each, questions 19 to 27 carry three marks each and questions 28 to 30 carry five marks each.
- (c) There is no overall choice. However, an internal choice has been provided in all three questions of five marks each. You have to attempt only one of the given choices in such questions.
- (d) Use of calculators is not permitted.
- (e) You may use the following physical constants wherever necessary :

$$c = 3 \times 10^8 \text{ m s}^{-1}$$

$$h = 6.6 \times 10^{-34} \text{ J s}$$

$$e = 1.6 \times 10^{-19} \text{ C}$$

$$\mu_0 = 4\pi \times 10^{-7} \text{ T m A}^{-1}$$

$$\frac{1}{4\pi\epsilon_0} = 9 \times 10^9 \frac{\text{Am}^2}{\text{C}^2}$$

$$\text{Boltzmann constant } k = 1.38 \times 10^{23} \text{ JK}^{-1}$$

$$\text{Avogadro's number } N_A = 6.023 \times 10^{23} / \text{mole}$$

$$\text{Mass of neutron } m_n = 1.6 \times 10^{-27} \text{ kg}$$

1. Two positive charges q_2 and q_3 fixed along the y axis, exert a net electric force in the $+x$ direction on a charge q_1 fixed along the x axis as shown. If a positive charge Q is added at $(x, 0)$, the force on q_1

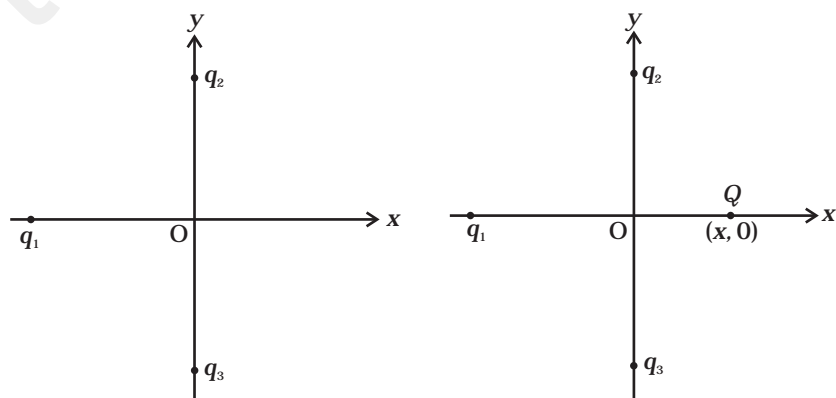

- (a) shall increase along the positive x -axis.
- (b) shall decrease along the positive x -axis.
- (c) shall point along the negative x -axis.
- (d) shall increase but the direction changes because of the intersection of Q with q_2 and q_3 .

2. Two batteries of emf ε_1 and ε_2 ($\varepsilon_2 > \varepsilon_1$) and internal resistances r_1 and r_2 respectively are connected in parallel as shown.

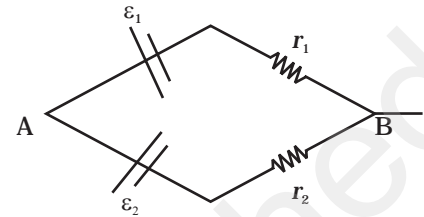

- (a) The equivalent emf ε_{eq} of the two cells is between ε_1 and ε_2 , i.e. $\varepsilon_1 < \varepsilon_{eq} < \varepsilon_2$.
 - (b) The equivalent emf ε_{eq} is smaller than ε_1 .
 - (c) The ε_{eq} is given by $\varepsilon_{eq} = \varepsilon_1 + \varepsilon_2$ always.
 - (d) ε_{eq} is independent of internal resistances r_1 and r_2 .
3. A proton has spin and magnetic moment just like an electron. Why then its effect is neglected in magnetism of materials?
4. If a LC circuit is considered analogous to a harmonically oscillating spring-block system, which energy of the LC circuit would be analogous to potential energy and which one analogous to kinetic energy?
5. A variable frequency ac source is connected to a capacitor. How will the displacement current change with decrease in frequency?
6. In pair annihilation, an electron and a positron destroy each other to produce gamma radiation. How is the momentum conserved?
7. Can the potential barrier across a p-n junction be measured by simply connecting a voltmeter across the junction?
8. The conductivity of a semiconductor increases with increase in temperature because
- (a) number density of free current carriers increases.
 - (b) relaxation time increases.
 - (c) both number density of carriers and relaxation time increase.
 - (d) number density of current carriers increases, relaxation time decreases but effect of decrease in relaxation time is much less than increase in number density.
9. Two charges q and $-3q$ are placed fixed on x -axis separated by distance ' d '. Where should a third charge $2q$ be placed such that it will not experience any force?
10. The battery remains connected to a parallel plate capacitor and a dielectric slab is inserted between the plates. What will be effect on its (i) potential difference, (ii) capacity, (iii) electric field, and (iv) energy stored?

11. Obtain an expression for the magnetic dipole moment of a revolving electron in a Bohr model.
12. A wire in the form of a tightly wound solenoid is connected to a DC source, and carries a current. If the coil is stretched so that there are gaps between successive elements of the spiral coil, will the current increase or decrease? Explain.
13. You are given a $2\mu\text{F}$ parallel plate capacitor. How would you establish an instantaneous displacement current of 1mA in the space between its plates?
14. There are two sources of light, each emitting with a power of 100 W . One emits X-rays of wavelength 1nm and the other visible light at 500 nm . Find the ratio of number of photons of X-rays to the photons of visible light of the given wavelength?
15. A particle is moving three times as fast as an electron. The ratio of the de Broglie wavelength of the particle to that of the electron is 1.813×10^{-4} . Calculate the particle's mass and identify the particle.
16. Consider two different hydrogen atoms. The electron in each atom is in an excited state. Is it possible for the electrons to have different energies but the same orbital angular momentum according to the Bohr model?
17. What do the terms 'depletion region' and 'barrier potential' mean for a p-n junction?
18. If the whole earth is to be connected by LOS communication using space waves (no restriction of antenna size or tower height), what is the minimum number of antennas required? Calculate the tower height of these antennas in terms of earth's radius?
19. Derive an expression (in vector form) for electric field of a dipole at a point on the equatorial plane of the dipole. How does the field vary at large distances?
20. What is relaxation time? Derive an expression for resistivity of a wire in terms of number density of free electrons and relaxation time.
21. First a set of n equal resistors of R each is connected in series to a battery of emf E and internal resistance R . A current I is observed to flow. Then the n resistors are connected in parallel to the same battery. It is observed that the current becomes 10 times. What is ' n '?
22. An equiconvex lens (of refractive index 1.50) is placed in contact with a liquid layer on top of a plane mirror as shown. A small needle with its tip on the principal axis is moved along the axis until its inverted image is found at the position of the needle. The distance of the needle from the lens is measured to be 45.0 cm . The liquid is removed and the experiment is repeated. The new distance is measured to be 30.0 cm . What is the refractive index of the liquid?

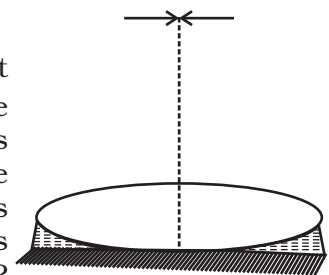

23. Obtain an expression for focal length of a combination of thin lenses in contact.
24. Three immiscible liquids of densities $d_1 > d_2 > d_3$ and refractive indices $\mu_1 > \mu_2 > \mu_3$ are put in a beaker. The height of each liquid column is $\frac{h}{3}$. A dot is made at the bottom of the beaker. For near normal vision, find the apparent depth of the dot.
25. Define 'half-life' and 'average-life' of a radioactive substance. What is the relation between the two?
26. Using a suitable combination from a NOR, an OR and a NOT gate, draw circuits to obtain the truth tables given below:

A	B	Y
0	0	0
0	1	0
1	0	1
1	1	0

(i)

A	B	Y
0	0	1
0	1	1
1	0	0
1	1	1

(ii)

27. Define the terms 'modulation index' for an AM wave. What would be the modulation index for an AM wave for which the maximum amplitude is 'a' and the minimum amplitude is 'b'?
28. (i) Derive an expression for the magnetic field at a point on the axis of a current carrying circular loop.
- (ii) A coil of 100 turns (tightly bound) and radius 10 cm. carries a current of 1A. What is the magnitude of the magnetic field at the centre of the coil?

OR

State Ampere's circuital law. Consider a long straight wire of a circular cross section (radius a) carrying steady current I . The current I is uniformly distributed across this cross section. Using Ampere's circuital law, find the magnetic field in the region $r < a$ and $r > a$.

29. An ac voltage $v = v_m \sin \omega t$ is applied to a series LCR circuit. Obtain the expression for current in the circuit and the phase angle between current and voltage. What is the resonance frequency?

OR

An ac voltage $v = v_m \sin \omega t$ is applied to a pure inductor L . Obtain an expression for the current in the circuit. Prove that the average power supplied to an inductor over one complete cycle is zero.

30. (i) State and explain Huygens Principle. Using it, obtain Snell's law of refraction.
- (ii) When light travels from a rarer to a denser medium, the speed decreases. Does the reduction in speed imply a reduction in the energy carried by the light wave?

OR

With the help of a labelled ray diagram show the image formation by a compound microscope. Derive an expression for its magnifying power. How can the magnifying power be increased?

© NCERT
not to be republished

SAMPLE PAPER I
SOLUTIONS AND MARKING SCHEME

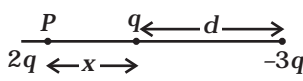
1. (a) (1)
2. (a) (1)
3. $\mu_p \approx \frac{e\hbar}{2m_p}$ and $\mu_e \approx \frac{e\hbar}{2m_e}$, $\hbar = \frac{h}{2\pi}$ (1/2)
 $\mu_e \gg \mu_p$ because $m_p \gg m_e$. (1/2)
4. Magnetic energy analogous to kinetic energy and electrical energy analogous to potential energy. (1/2), (1/2)
5. On decreasing the frequency, reactance $X_c = \frac{1}{\omega C}$ will increase which will lead to decrease in conduction current. In this case $i_d = i_c$; hence displacement current will decrease. (1/2, 1/2)
6. 2γ photons are produced which move in opposite directions to conserve momentum. (1)
7. No, because the voltmeter must have a resistance very high compared to the junction resistance, the latter being nearly infinite. (1/2, 1/2)
8. (d) (1)
9. At P: on $2q$, Force due to q is to the left and that due to $-3q$ is to the right.
 $\therefore \frac{2q^2}{4\pi\epsilon_0 x^2} = \frac{6q^2}{4\pi\epsilon_0 (d+x)^2}$ (1/2)
 $\therefore (d+x)^2 = 3x^2$
 $\therefore 2x^2 - 2dx - d^2 = 0$
 $x = \frac{d}{2} \pm \frac{\sqrt{3}d}{2}$ (1/2)

 (Negative sign would be between q and $-3q$ and hence is unacceptable.)
 $x = \frac{d}{2} + \frac{\sqrt{3}d}{2} = \frac{d}{2}(1 + \sqrt{3})$ to the left of q . (1)
10. When battery remains connected,
 - (i) potential difference V remains constant. (1/2)
 - (ii) capacity C increases. (1/2)

(iii) electric field will decrease. (1/2)

(iv) energy stored $(1/2)CV^2$ increases as C increases. (1/2)

11. $I = e / T$ (1/2)

$T = 2\pi r / v$ (1/2)

$\mu_l = IA = I\pi r^2 = evr / 2$ (1/2)

$\mu_l = \frac{e}{2m_e} l$ (1/2)

12. The current will increase. As the wires are pulled apart, the flux will leak through the gaps. Lenz's law demands that induced e.m.f. resist this decrease, which can be done by an increase in current. (1,1)

13. $i_D = C \frac{dV}{dt}$ (1/2)

$$1 \times 10^{-3} = 2 \times 10^{-6} \frac{dV}{dt}$$

$\frac{dV}{dt} = \frac{1}{2} \times 10^3 = 5 \times 10^2 \text{ V/s}$ (1/2)

Hence, applying a varying potential difference of $5 \times 10^2 \text{ V/s}$ would produce a displacement current of the desired value. (1)

14. Total E is constant. (1/2)

Let n_1 and n_2 be the number of photons of X-rays and light of visible region:

$n_1 E_1 = n_2 E_2$ (1/2)

$$n_1 \frac{hc}{\lambda_1} = n_2 \frac{hc}{\lambda_2}$$

$\frac{n_1}{n_2} = \frac{\lambda_1}{\lambda_2}$ (1/2)

$\frac{n_1}{n_2} = \frac{1}{500}$ (1/2)

15. de Broglie wavelength of a moving particle, having mass m and velocity v :

$$\lambda = h/p = h/mv$$

Mass, $m = h/\lambda v$ (1/2)

For an electron, mass $m_e = h/\lambda_e v_e$

Exemplar Problems–Physics

Now, we have $v/v_e = 3$ and $\lambda/\lambda_e = 1.813 \times 10^{-4}$ (1/2)

Then, mass of the particle, $m = m_e (\lambda_e/\lambda) (v_e/v)$ (1/2)

$$m = (9.11 \times 10^{-31} \text{ kg}) \times (1/3) \times (1/1.813 \times 10^{-4})$$

$$m = 1 \times 1.675 \times 10^{-27} \text{ kg.}$$

Thus, the particle, with this mass could be a proton or a neutron. (1/2)

16. No, because according to Bohr model, $E_n = -\frac{13.6}{n^2}$, (1)

and electrons having different energies belong to different levels having different values of n .

So, their angular momenta will be different, as $mvr = \frac{nh}{2\pi}$. (1)

17. Definition : depletion region (1)

Definition : barrier potential (1)

18. $d_m^2 = 2(R + h_T)^2$ (1/2)

$$8Rh_T = 2(R+h_T)^2 \quad (Q \ d_m = 2\sqrt{2Rh_T})$$

$$4Rh_T = R^2 + h_T^2 + 2Rh_T$$

$$(R - h_T)^2 = 0$$

$$R = h_T \quad (1/2)$$

Since space wave frequency is used, $\lambda \ll h_T$, hence only tower height is taken to consideration. In three dimensions, 6 antenna towers of $h_T = R$ would do. (1)

19. Derivation (2)

At large distances, $E \propto 1/r^3$ (1)

20. Definition and Derivation (3)

21. $I = E/(R+nR)$ (1)

$$10I = E/(R+R/n) \quad (1)$$

$$(1+n)/(1+1/n) = 10 = \{(1+n)/(n+1)\}n = n, \quad n = 10. \quad (1)$$

22. $\mu = 1.5$. 45cm is focal length of the combination of convex lens and plano convex liquid

lens. When liquid is removed, $f_1 = 30$ cm is the focal length of convex lens only. If f_2 is the focal length of plano-convex liquid lens,

$$\frac{1}{f_1} + \frac{1}{f_2} = \frac{1}{f} \quad (1/2)$$

$$\frac{1}{f_2} = \frac{1}{f} - \frac{1}{f_1} = \frac{1}{45} - \frac{1}{30} = \frac{-1}{90}, f_2 = -90 \text{ cm} \quad (1/2)$$

Using lens maker's formula, $R_1 = R, R_2 = -R$

$$\frac{1}{f_2} = (\mu - 1) \left(\frac{1}{R_1} - \frac{1}{R_2} \right) \Rightarrow \frac{1}{-90} = (1.5 - 1) \left(\frac{1}{R} + \frac{1}{R} \right) \Rightarrow R = 30 \text{ cm} \quad (1/2, 1/2)$$

For plano-convex lens

$$\frac{1}{f_2} = (\mu - 1) \left(\frac{1}{R_1} - \frac{1}{R_2} \right) \quad (1/2)$$

$$-\frac{1}{90} = (\mu - 1) \left(\frac{1}{\infty} - \frac{1}{30} \right) = \frac{\mu - 1}{-30}$$

$$\mu = 1.33 \quad (1/2)$$

23. Derivation, $\frac{1}{f} = \frac{1}{f_1} + \frac{1}{f_2} + \dots \quad (3)$

24. Let the apparent depth be O_1 for the object seen from μ_2 then

$$O_1 = \frac{\mu_2 h}{\mu_1 3} \quad (1)$$

If seen from μ_3 , the apparent depth is O_2

$$O_2 = \frac{\mu_3}{\mu_2} \left(\frac{h}{3} + O_1 \right) = \frac{\mu_3}{\mu_2} \left(\frac{h}{3} + \frac{\mu_2 h}{\mu_1 3} \right) = \frac{h}{3} \left(\frac{\mu_3}{\mu_2} + \frac{\mu_3}{\mu_1} \right) \quad (1)$$

Seen from outside, the apparent height is

$$O_3 = \frac{1}{\mu_3} \left(\frac{h}{3} + O_2 \right) = \frac{1}{\mu_3} \left[\frac{h}{3} + \frac{h}{3} \left(\frac{\mu_3}{\mu_2} + \frac{\mu_3}{\mu_1} \right) \right] \quad (1)$$

$$= \frac{h}{3} \left(\frac{1}{\mu_1} + \frac{1}{\mu_2} + \frac{1}{\mu_3} \right)$$

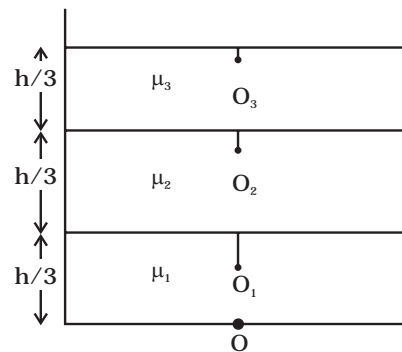

25. Definition and expression: Half Life (1/2,1/2)
 Definition and expression: Average life (1/2,1/2)
 Relation between the two. (1)

26. Output not symmetric for A, B = (0,1) and (1,0). NOT gate in one input. (1)

(i) has three zero. NOR gate.

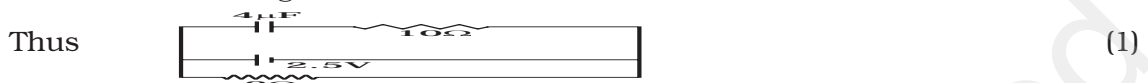

(ii) has three ones. OR gate.



27. $\mu = A_m/A_c$ (1)

$$a = A_c + A_m$$

$$b = A_c - A_m \quad (1/2)$$

$$A_c = (a + b)/2, A_m = (a - b)/2 \quad (1/2)$$

$$\mu = (a - b)/(a + b) \quad (1)$$

28. (i) Derivation (3)

(ii) Since the coil is tightly bound, we may take each circular element to have the same radius $R = 10\text{cm} = 0.1\text{m}$. $N=100$. The magnitude of the magnetic field is

$$B = \mu_0 N I / (2 R) = 4\pi \times 10^{-7} \times 10^{-2} \times 1 / (2 \times 10^{-1}) = 2\pi \times 10^{-4} = 6.28 \times 10^{-4} \text{T}. \quad (2)$$

OR

Statement of Ampere's law (1)

Derivation of $B = \mu_0 I / 2\pi r$, for $r > a$ (2)

Derivation of $B = (\mu_0 I / 2\pi a^2) r$, for $r < a$ (2)

29. Derivation (4)

Resonance frequency (1)

OR

Derivation (3)

Proof (2)

30. (i) Statement and explanation (1)

Derivation of Snell's law (3)

- (ii) No. Energy carried by a wave depends on the amplitude of the wave, not on the speed of wave propagation. (1)

OR

- (iii) Labelled ray diagram (1)

Derivation $m = \frac{L}{f_o} \left(1 + \frac{D}{f_e} \right)$ (2)

To Increase magnifying power, the objective and eyepiece should have small focal lengths. In practice, it is difficult to make the focal length much smaller than 1 cm. Also large lenses are required to make L large. (1)

CLASS XII
PHYSICS
BLUE - PRINT II

Topic	VSA (1 mark)	SA II (2 marks)	SA I (3 Marks)	LA (5 marks)	Total
I Electrostatics	1(1)	2 (1)	—	5 (1)	8 (3)
II Current Electricity	—	4 (2)	3 (1)	—	7 (3)
III Magnetic Effect of Current and Magnetism	1 (1)	4 (2)	3 (1)	—	8 (4)
IV Electromagnetic Induction and Alternating Current	1(1)	2 (1)	—	5 (1)	8 (3)
V Electromagnetic Waves	1 (1)	2 (1)	—	—	3 (2)
VI Optics	2 (2)	4 (2)	3 (1)	5 (1)	14 (6)
VII Dual Nature of Radiation and Matter	1 (1)	—	3 (1)	—	4 (2)
VIII Atoms and Nuclei	—	—	6 (2)	—	6 (2)
IX Semiconductor Electronics	1 (1)	—	6 (2)	—	7 (3)
X Communication Systems	—	2 (1)	3(1)	—	5 (2)
Total	8 (8)	20 (10)	27 (9)	15 (3)	70 (30)

SAMPLE PAPER II
XII - PHYSICS

Time : Three Hours

Max. Marks : 70

General Instructions

- (a) All questions are compulsory.
- (b) There are 30 questions in total. Questions 1 to 8 carry one mark each, questions 9 to 18 carry two marks each, questions 19 to 27 carry three marks each and questions 28 to 30 carry five marks each.
- (c) There is no overall choice. However, an internal choice has been provided in all three questions of five marks each. You have to attempt only one of the given choices in such questions.
- (d) Use of calculators is not permitted.
- (e) You may use the following physical constants wherever necessary :

$$c = 3 \times 10^8 \text{ms}^{-1}$$

$$h = 6.6 \times 10^{-34} \text{Js}$$

$$e = 1.6 \times 10^{-19} \text{C}$$

$$\mu_0 = 4\pi \times 10^{-7} \text{T m A}^{-1}$$

$$\frac{1}{4\pi\epsilon_0} = 9 \times 10^9 \frac{\text{Am}^2}{\text{C}^2}$$

$$\text{Boltzmann constant } k = 1.38 \times 10^{-23} \text{JK}^{-1}$$

$$\text{Avogadro's number } N_A = 6.023 \times 10^{23} / \text{mole}$$

$$\text{Mass of neutron } m_n = 1.6 \times 10^{-27} \text{kg}$$

1. A capacitor of $4 \mu\text{F}$ is connected in a circuit as shown. The internal resistance of the battery is 0.5Ω . The amount of charge on the capacitor plates will be
- (a) 0
(b) $4 \mu\text{C}$
(c) $16 \mu\text{C}$
(d) $8 \mu\text{C}$

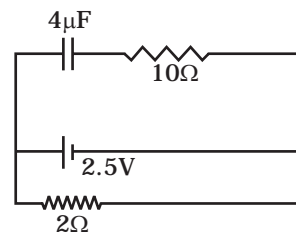

2. Two charged particles traverse *identical* helical paths in a completely opposite sense in a uniform magnetic field $\mathbf{B} = B_0 \hat{\mathbf{k}}$.
- They have equal z-components of momenta.
 - They must have equal charges.
 - They necessarily represent a particle-antiparticle pair.
 - The charge to mass ratio satisfy : $\left(\frac{e}{m}\right)_1 + \left(\frac{e}{m}\right)_2 = 0$.
3. A solenoid is connected to a battery so that a steady current flows through it. If an iron core is inserted into the solenoid, will the current increase or decrease? Explain.
4. Professor C.V Raman surprised his students by suspending freely a tiny light ball in a transparent vacuum chamber by shining a laser beam on it. Which property of EM waves was he exhibiting? Give one more example of this property.
5. A passenger in an aeroplane shall
- never see a rainbow.
 - may see a primary and a secondary rainbow as concentric circles.
 - may see a primary and a secondary rainbow as concentric arcs.
 - shall never see a secondary rainbow.
6. What is the shape of the wavefront on earth for sunlight?
7. An electron (mass m) with an initial velocity $\mathbf{v} = v_0 \hat{\mathbf{i}}$ ($v_0 > 0$) is in an electric field $\mathbf{E} = -E_0 \hat{\mathbf{i}}$ ($E_0 = \text{constant} > 0$). It's de Broglie wavelength at time t is given by
- $\frac{\lambda_0}{\left(1 + \frac{eE_0 t}{m v_0}\right)}$
 - $\lambda_0 \left(1 + \frac{eE_0 t}{m v_0}\right)$
 - λ_0
 - $\lambda_0 t$.
8. Explain why elemental semiconductors cannot be used to make visible LED's.
9. Five charges, q each are placed at the corners of a regular pentagon of side 'a' as shown.

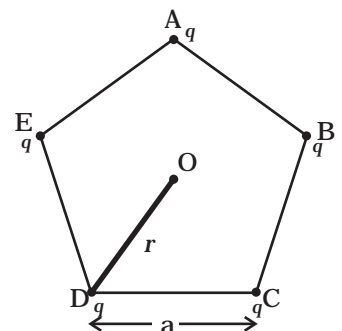

- (i) What will be the electric field at O if the charge from one of the corners (say A) is removed?
- (ii) What will be the electric field at O if the charge q at A is replaced by $-q$?
10. Two cells of *emf* E_1 and E_2 have internal resistance r_1 and r_2 . Deduce an expression for equivalent *emf* of their parallel combination.
11. Draw a circuit diagram of a potential divider using a cell and a rheostat. Also mark the output terminals.
12. If magnetic monopoles existed, how would the Gauss's law of magnetism be modified?
13. From molecular viewpoint, discuss the temperature dependence of susceptibility for diamagnetism, paramagnetism and ferromagnetism.
14. A lamp is connected in series with a capacitor. Predict your observations for dc and ac connections. What happens in each case if the capacitance of the capacitor is reduced?
15. A plane electromagnetic wave of frequency 25 MHz travels in free space along the x-direction. At a particular point in space and time. $\mathbf{E} = 6.3 \hat{j}$ V/m. What is \mathbf{B} at this point?
16. Define power of a lens. Show that it is inversely proportional to the focal length of the lens.
17. Two slits are made one millimetre apart and the screen is placed one metre away. What is the fringe separation when blue-green light of wavelength 500 nm is used?
18. A message signal of frequency 10 kHz and peak voltage of 10 volts is used to modulate a carrier of frequency 1 MHz and peak voltage of 20 volts. Determine (a) modulation index, and (b) the side bands produced.
19. Draw a circuit for determining internal resistance of a cell using a potentiometer. Explain the principle on which this method is based.
20. What do you mean by diamagnetism, paramagnetism and ferromagnetism?
21. For the same objective, find the ratio of the least separation between two points to be distinguished by a microscope for light of 5000 Å and electrons accelerated through 100V used as the illuminating substance.
22. Monochromatic light of frequency 6.0×10^{14} Hz is produced by a laser. The power emitted is 2.0×10^{-3} W. (i) What is the energy of a photon in the light beam? (ii) How many photons per second, on an average, are emitted by the source?

23. State Bohr's postulate for the 'permitted orbits' for electrons in a hydrogen atom. How this postulate was explained by de Broglie?
24. Explain a beta decay process with an example. Tritium has a half life of 12.5y undergoing beta decay. What fraction of a sample of pure tritium will remain undecayed after 25 y?
25. What is rectification? With the help of a labelled circuit diagram, explain full wave rectification using junction diode.
26. Explain briefly, with the help of a circuit diagram, how $V-I$ characteristics of a p-n junction diode are obtained in (i) forward bias, and (ii) reverse bias. Draw the shapes of the curves obtained.
27. (i) Draw a block diagram of a communication system.
(ii) What is meant by 'detection' of amplitude modulated wave? Describe briefly the essential steps for detection.
28. Derive an expression for potential due to a dipole for distances large compared to the size of the dipole. How is the potential due to a dipole different from that due to a single charge?

OR

Obtain an expression for potential energy of a system of two charges in an external field.

A system consisting of two charges $7\mu\text{C}$ and $-2\mu\text{C}$ are placed at $(-9\text{ cm}, 0,0)$ and $(9\text{ cm},0,0)$ respectively in an external electric field $E = A (1/r^2)$ where $A = 9 \times 10^5\text{ C m}^2$. Calculate the potential energy of this system.

29. Define 'self inductance' of a coil. Obtain an expression for self inductance of a long solenoid of cross sectional area A , length l having n turns for unit length. Prove that self inductance is the analogue of mass in mechanics.

OR

Define 'mutual inductance' of two coils. On what factors it depends?

Two concentric circular coils, one of small radius r_1 and the other of large radius r_2 , such that $r_1 \ll r_2$, are placed co-axially with centres coinciding. Obtain the mutual inductance of the arrangement.

30. Draw a ray diagram to show two refraction of light through a glass prism. Explain with help of a diagram the dependence of angle of deviation on the angle of incidence. Hence obtain the relation for the angle of minimum deviation in terms of angle of prism and refractive index of prism.

OR

- (i) Using the relation for refraction at a single spherical refracting surface, derive the lens maker's formula.
- (ii) Double convex lenses are to be manufactured from a glass of refraction index 1.55 with both faces of the same radius of curvature. What is the radius of curvature required if the focal length is to be 20.0 cm?

© NCERT
not to be republished

SAMPLE PAPER II
SOLUTIONS AND MARKING SCHEME

1. (a) (1)
2. (d) (1)
3. The current will decrease. As the iron core is inserted in the solenoid, the magnetic field increases and the flux increases. Lenz's law implies that induced e.m.f. should resist this increase, which can be achieved by a decrease in current. (1)
4. EM waves exert radiation pressure. Tails of comets are due to solar radiation. (1/2, 1/2)
5. (b) (1)
6. Spherical with huge radius as compared to the earth's radius so that it is almost a plane. (1/2, 1/2)
7. (a) (1)
8. Elemental semiconductor's band-gap is such that emissions are in infra-red region. (1/2, 1/2)
9. (i) $\frac{1}{4\pi\epsilon_0} \frac{q}{r^2}$ along **OA** (1)
- (ii) $\frac{1}{4\pi\epsilon_0} \frac{2q}{r^2}$ along **OA** (1)
10. $I = I_1 + I_2$ (1/2)

$$= \frac{E_1 - V}{r_1} + \frac{E_2 - V}{r_2}$$

$$I = \left(\frac{E_1}{r_1} + \frac{E_2}{r_2} \right) - V \left(\frac{1}{r_1} + \frac{1}{r_2} \right)$$

$$V = \frac{E_1 r_2 + E_2 r_1}{r_1 + r_2} - I \left(\frac{r_1 + r_2}{r_1 + r_2} \right)$$
 (1/2)
 Comparing with $V = E_{\text{eq}} - I r_{\text{eq}}$ (1/2)
 We get, $E_{\text{eq}} = \frac{E_1 r_2 + E_2 r_1}{r_1 + r_2}$ (1/2)

11. Figure shows the desired circuit. The output voltage is obtained across. A and C. (1, 1)

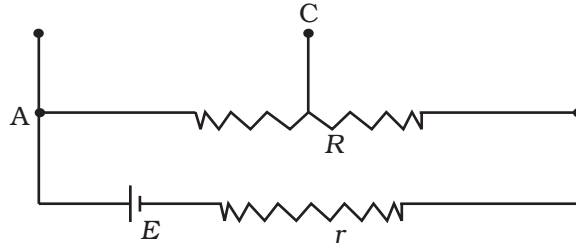

12. Gauss's law of magnetism states that the flux of \mathbf{B} through any closed surface is always zero, $\oint \mathbf{B} \cdot d\mathbf{s} = 0$ (1)

If monopole existed, the right hand side would be equal to monopole (magnetic charge, q_m) multiplied by μ_0 .

$$\oint \mathbf{B} \cdot d\mathbf{s} = \mu q_m . \quad (1)$$

13. Diamagnetism is due to orbital motion of electrons developing magnetic moments opposite to applied field and hence is not much affected by temperature. (1)

Paramagnetism and ferromagnetism is due to alignments of atomic magnetic moments in the direction of the applied field. As temperature increases, this alignment is disturbed and hence susceptibilities of both decrease as temperature increases. (1)

14. When a dc source is connected to a capacitor, the capacitor gets charged and after charging no current flows in the circuit and the lamp will not glow. There will be no change even if C is reduced. (1)

With ac source, the capacitor offers capacitive reactance ($1/\omega C$) and the current flows in the circuit. Consequently, the lamp will shine. Reducing C will increase reactance and the lamp will shine less brightly than before. (1)

15. The magnitude of \mathbf{B} is

$$B = \frac{E}{c}$$

$$= \frac{6.3\text{V/m}}{3 \times 10^8 \text{m/s}} = 2.1 \times 10^{-8} \text{T} \quad (1)$$

To find the direction, we note that \mathbf{E} is along y -direction and the wave propagated along x -axis. Therefore, \mathbf{B} should be in a direction perpendicular to both x -, and y -axes. Using vector algebra, $\mathbf{E} \times \mathbf{B}$ should be along x -direction. Since, $(+\hat{\mathbf{j}}) \times (+\hat{\mathbf{k}}) = \hat{\mathbf{i}}$, \mathbf{B} is along the z -direction.

Thus, $\mathbf{B} = 2.1 \times 10^{-8} \hat{\mathbf{k}} \text{T}$. (1)

16. $P = \tan \delta$ with diagram (1)

$$= h / f = \frac{1}{f}$$

For small δ , $\tan \delta \sim \delta$. $P = 1/f$ (1)

17. Fringe spacing $= \frac{D\lambda}{d}$ (1)

$$= \frac{1 \times 5 \times 10^{-7}}{1 \times 10^{-3}} 0.5 \text{mm} \quad (1)$$

18. Modulation index = $10/20 = 0.5$ (1)

Side bands are at 1010 kHz and 990 kHz. (1)

19. Diagram (1)

$$E = \phi I_1 \quad (1/2)$$

$$V = \phi I_2 \quad E/V = I_1/I_2 \quad (1/2)$$

$$E = I(r+R), \quad V = IR$$

$$E/V = (r+R)/R \quad (1/2)$$

$$r = R \{(I_1/I_2) - 1\}. \quad (1/2)$$

20. Diamagnetism (1)

Paramagnetism (1)

Ferromagnetism (1)

21. $d_{\min} = \frac{1.22\lambda}{2 \sin \beta}$ (1/2)

where β is the angle subtended by the objective at the object.

For light of 5500 \AA

$$d_{\min} = \frac{1.22 \times 5.5 \times 10^{-7}}{2 \sin \beta} \text{m} \quad (1)$$

For electrons accelerated through 100V, the deBroglie wavelength is

$$\lambda = \frac{h}{p} = \frac{1.227}{\sqrt{100}} = 0.13 \text{ nm} = 0.13 \times 10^{-9} \text{ m} \quad (1/2)$$

$$\therefore d'_{\min} = \frac{1.22 \times 1.3 \times 10^{-10}}{2 \sin \beta} \quad (1/2)$$

$$\frac{d_{\min}}{d'_{\min}} = 0.2 \times 10^{-3} \quad (1/2)$$

22. (i) Each photon has an energy

$$\begin{aligned} E &= h\nu = (6.63 \times 10^{-34} \text{ J s}) (6.0 \times 10^{14} \text{ Hz}) \\ &= 3.98 \times 10^{-19} \text{ J} \end{aligned} \quad (1)$$

- (ii) If N is the number of photons emitted by the source per second, the power P transmitted in the beam equals N times the energy per photon E , so that $P = NE$. Then

$$N = \frac{P}{E} \quad (1)$$

$$= \frac{2.0 \times 10^{-3} \text{ W}}{3.98 \times 10^{-19} \text{ J}} = 5.0 \times 10^{15} \text{ photons per second.} \quad (1)$$

23. Postulate (1)

de Broglie explanation (2)

24. Explanation (1)

Example (1)

Answer : 1/4 of sample (1)

25. Rectification (1/2)

Labelled diagram (1/2)

Explanation (2)

26. Circuit diagram for obtaining characteristic curves (1)

Explanation (1)

- Shape of curves (1)
27. (i) Block diagram of communication system (1)
- (ii) Block diagram of a detector (1)
- Explanation (1)
28. Derivation (4)
- Difference (1)
- OR
- Derivation (3)
- Numerical (2)
29. Definition (1)
- Derivation of expression (2)
- Proof (2)
- OR
- Definition of mutual inductance (1)
- Dependence on factors (1)
- Numerical (3)
30. Labelled diagram (1)
- Diagram of δ versus e (1)
- Derivation $\delta_m = (\mu - 1)A$ (3)
- OR
- (i) Derivation (3)
- (ii) $\mu = 1.55, R_1 = R$ (1/2)
- $R_2 = -R, f = 20$ cm.
- $$\frac{1}{f} = (\mu - 1) \left(\frac{1}{R_1} - \frac{1}{R_2} \right) \quad (1/2)$$
- $$\frac{1}{20} = (1.55 - 1) \left(\frac{1}{R_1} + \frac{1}{R_2} \right) = \frac{1.10}{R} \quad (1/2)$$
- $R = 20 \times 1.1 = 22$ cm. (1/2)