

CRASH COURSE FOR
PEAK PERFORMANCE

ebook

rapid PHYSICS



- HIGH YIELD FACTS
- EASY TO GRASP
- ESSENTIAL PHYSICS
FOR COMPETITIVE EXAMS

<https://rebrand.ly/DownloadMore>



Copyright © 2014 MTG Learning Media (P) Ltd. No part of this publication may be reproduced, transmitted, in any form or by any means, electronic, mechanical, photocopying, recording or otherwise, without the prior permission of the Publisher. Ownership of an ebook does not give the possessor the ebook copyright.
All disputes subject to Delhi jurisdiction only.

Disclaimer : The information in this book is to give you the path to success but it does not guarantee 100% success as the strategy is completely dependent on its execution.

Published by : MTG Learning Media (P) Ltd.
Corporate Office : Plot 99, 2nd Floor, Sector 44 Institutional Area, Gurgaon, Haryana.
Phone : 0124 - 4219385, 4219386
Web: mtg.in Email: info@mtg.in

Head Office : 406, Taj Apt., Ring Road, Near Safdarjung Hospital, New Delhi-110029

Visit www.mtg.in for buying books online.

OTHER RECOMMENDED BOOKS

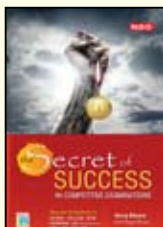

Science of
Achievement

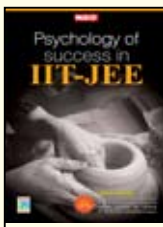

Psychology of
Success



Master Mental
Ability in 30 Days



Science IQ
Challenge

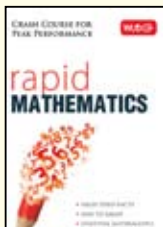

rapid
MATHEMATICS

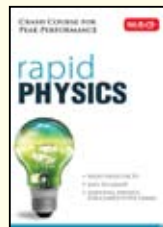

rapid
PHYSICS

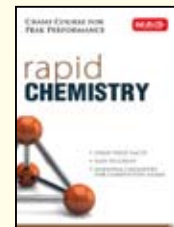

rapid
CHEMISTRY

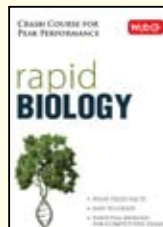

rapid
BIOLOGY

<https://rebrand.ly/DownloadMore>

P R E F A C E

“Good things come in small packages.”

Rapid Physics (**High Yield Facts** Book) is designed for people who have only enough time to glance at a book-literally. Our goal is to create an effective memory aid for those who wish to review physics.

The book covers complete syllabus in points form. The quality of the writing leaves the reader with the potential to achieve a good understanding of a given topic within a short period of learning. It gives a concise overview of the main theories and concepts of physics, for students studying physics and related courses at undergraduate level. Based on the highly successful and student friendly “at a glance” approach, the material developed in this book has been chosen to help the students grasp the essence of physics, ensuring that they can confidently use that knowledge when required.

The books has been crafted extremely well for a very specific purpose: review. A person who has been away from physics (but who understood it very well at the time) can use this book effectively for a rapid review of any basic topic. The book is so highly compressed that every page is like a food with a rich sauce that needs to be slowly savored and slowly digested for maximum benefit. You may only glance into the book, but you can think about the physics for much longer.

All the best!

Impetus by : **Prof. S.P. Arya**
& **Geeta Mahajan**

contents

	Page No.
1. Units and Measurement	1
2. Kinematics and Vectors.....	14
3. Laws of Motion	29
4. Work, Power and Energy.....	38
5. Rotational Motion	44
6. Gravitation	50
7. Properties of Matter	55
8. Oscillations	73
9. Waves.....	80
10. Heat and Thermodynamics.....	96
11. Electrostatics	115
12. Current Electricity	126
13. Thermal and Chemical Effects of Current.....	136
14. Magnetic Effect of Current	142
15. Magnetism.....	149
16. Electromagnetic Induction and A.C.....	161
17. Electromagnetic Waves	175
18. Ray Optics	179
19. Wave Optics.....	189
20. Modern Physics.....	199
21. Solids and Semiconductor Devices.....	211
22. Principles of Communication	221
23. Practical Physics	225

units and measurement

• Units and dimensional formulae of some important physical quantities

S. No.	Physical quantity	Dimensional formula	C.G.S. units	M.K.S. units
1.	Area	$[M^0L^2T^0]$	cm ²	m ²
2.	Volume	$[M^0L^3T^0]$	cm ³	m ³
3.	Density = mass/volume	$[ML^{-3}T^0]$	g cm ⁻³	kg m ⁻³
4.	Speed or velocity = $\frac{dx}{dt}$	$[M^0LT^{-1}]$	cm s ⁻¹	m s ⁻¹
5.	Acceleration = $\frac{dv}{dt}$	$[M^0LT^{-2}]$	cm s ⁻²	m s ⁻²
6.	Force = $mdv/dt = ma$	$[MLT^{-2}]$	g cm s ⁻² or dyne	kg m s ⁻² or N
7.	Linear Momentum ($p = mv$)	$[MLT^{-1}]$	g cm s ⁻¹ or dyne s	kg m s ⁻¹ or Ns
8.	Impulse = $F \cdot \Delta t$	$[MLT^{-1}]$	g cm s ⁻¹ or dyne s	kg m s ⁻¹ or Ns
9.	Power = work/time	$[ML^2T^{-3}]$	erg s ⁻¹ or g cm ² s ⁻³	J sec ⁻¹ or watt or kg m ² s ⁻³
10.	Work or Energy = force \times displacement	$[ML^2T^{-2}]$	dyne cm or erg	Nm or J or kg m ² s ⁻² or g cm ² s ⁻²
11.	Pressure or Stress = force/area	$[ML^{-1}T^{-2}]$	dyne cm ⁻² or g cm ⁻¹ s ⁻²	N m ⁻² or kg m ⁻¹ s ⁻²
12.	Strain = $\frac{\Delta l}{l}$ or $\frac{\Delta V}{V}$	$[M^0L^0T^0]$	No unit	No unit
13.	Specific gravity or Relative density = $\frac{\text{density of body}}{\text{density of water}}$	$[M^0L^0T^0]$	No unit	No unit

S. No.	Physical quantity	Dimensional formula	C.G.S. units	M.K.S. units
14.	Angular displacement	$[M^0L^0T^0]$	radian or degree	radian or degree
15.	Poisson's ratio $= \frac{\text{lateral strain}}{\text{longitudinal strain}}$	$[M^0L^0T^0]$	No unit	No unit
16.	Modulus of elasticity $= \text{stress/strain}$	$[ML^{-1}T^{-2}]$	dyne cm^{-2} or $\text{g cm}^{-1} \text{s}^{-2}$	N m^{-2} or $\text{kg m}^{-1}\text{s}^{-2}$
17.	Surface tension $= \text{force/length}$	$[ML^0T^{-2}]$	dynes cm^{-1} or g s^{-2}	N m^{-1} or kg s^{-2}
18.	Velocity gradient $= \frac{dv}{dx}$	$[M^0L^0T^{-1}]$	second ⁻¹	second ⁻¹
19.	Coefficient of viscosity $\eta = \frac{F \cdot dx}{A \cdot dv}$	$[ML^{-1}T^{-1}]$	$\text{g cm}^{-1} \text{s}^{-1}$ or poise	$\text{kg m}^{-1} \text{s}^{-1}$
20.	Torque or Moment of force $= \text{Force} \times \text{perpendicular distance of force from axis}$	$[ML^2T^{-2}]$	$\text{g cm}^2 \text{sec}^{-2}$ or dyne cm	$\text{kg m}^2 \text{sec}^{-2}$ or N m
21.	Gravitational constant (G) $= F \times d^2 / m_1m_2$	$[M^{-1}L^3T^{-2}]$	$\text{g}^{-1} \text{cm}^3 \text{s}^{-2}$ or $\frac{\text{dyne cm}^2}{\text{g}^2}$	$\text{kg}^{-1} \text{m}^3 \text{s}^{-2}$ or $\frac{\text{N m}^2}{\text{kg}^2}$
22.	Moment of Inertia $I = Mk^2$	$[ML^2T^0]$	g cm^2	kg m^2
23.	Angular velocity, $(\omega = d\theta/dt)$	$[M^0L^0T^{-1}]$	radian/s	radian/s
24.	Frequency ($f = 1/T$)	$[T^{-1}]$	cycle/s or Hz	cycle/s or Hz
25.	Angular acceleration $\alpha = d\omega/dt$	$[M^0L^0T^{-2}]$	radian/ s^2	radian/ s^2
26.	Angular momentum ($L = I\omega$)	$[ML^2T^{-1}]$	$\text{g cm}^2 \text{s}^{-1}$	$\text{kg m}^2 \text{s}^{-1}$
27.	Torque ($\tau = I\alpha$)	$[ML^2T^{-2}]$	$\text{g cm}^2 \text{s}^{-2}$	$\text{kg m}^2 \text{s}^{-2}$
28.	Intensity of gravitational field $(= F/m)$	$[M^0LT^{-2}]$	cm s^{-2}	m s^{-2}
29.	Gravitational potential $= \text{work/mass}$	$[M^0L^2T^{-2}]$	$\text{cm}^2 \text{s}^{-2}$	$\text{m}^2 \text{s}^{-2}$
30.	Force constant or spring constant $= \text{force/displacement}$	$[ML^0T^{-2}]$	g s^{-2} or dyne per cm	kg s^{-2} or N per m

S. No.	Physical quantity	Dimensional formula	C.G.S. units	M.K.S. units
31.	Heat energy	$[ML^2T^{-2}]$	calorie	kilocalorie
32.	Specific heat = $H/m\theta$	$[L^2T^{-2}\theta^{-1}]$	calorie $g^{-1}\text{°C}^{-1}$	k cal $kg^{-1} K^{-1}$
33.	Mechanical equivalent of heat ($J = W/H$)	$[M^0L^0T^0]$	$\frac{\text{erg}}{\text{calorie}}$	$\frac{\text{joule}}{\text{kcal}}$
34.	Thermal conductivity $K = \frac{H}{At (d\theta / dx)}$	$[MLT^{-3}\theta^{-1}]$	cal $cm^{-1} s^{-1} \text{°C}^{-1}$	kcal $m^{-1} s^{-1} K^{-1}$
35.	Universal gas constant $R = PV/nT$	$[ML^2T^{-2}\theta^{-1}]$	erg/mole °C	J/mole K
36.	Boltzmann constant $k_B = R/N$	$[ML^2T^{-2}\theta^{-1}]$	erg °C^{-1}	J K^{-1}
37.	Planck's constant	$[ML^2T^{-1}]$	erg or $g\text{ cm}^2\text{ s}^{-1}$	J s or $kg\text{ m}^2\text{ s}^{-1}$
38.	Thermal Resistance	$[M^{-1}L^{-2}T^3\theta]$	$\frac{\text{°C} \times \text{sec}}{\text{cal}}$	$\frac{K \times \text{sec}}{\text{kcal}}$

● Some important abbreviations

Symbol	Prefix	Multiplier
d	deci	10^{-1}
c	centi	10^{-2}
m	milli	10^{-3}
μ	micro	10^{-6}
n	nano	10^{-9}
p	pico	10^{-12}
f	femto	10^{-15}
a	atto	10^{-18}
da	deca	10^1
h	hecto	10^2
k	kilo	10^3
M	mega	10^6
G	giga	10^9
T	tera	10^{12}
P	pecta	10^{15}
E	exa	10^{18}

Significant figure rule

- So far **significant figures** are concerned, in mathematical operations like addition and subtraction, the result would be correct upto minimum number of decimal places in any of quantities involved. However, in multiplication and division, number of significant figures in the result will be limited corresponding to the minimum number of significant figures in any of the quantities involved.
To represent the result to a correct number of significant figures, we round off as per the rules.
- There are three rules on determining how many significant figures are in a number :
 - (i) Non-zero digits are always significant.
 - (ii) Any zeros between two significant digits are significant.
 - (iii) A final zero or trailing zeros in the decimal portion **ONLY** are significant.
- All numbers are based upon measurements (except for a very few that are defined). Since all measurements are uncertain, we must only use those numbers that are meaningful. A common ruler cannot measure something to be 22.4072643 cm long. Not all of the digits have meaning (significance) and, therefore, should not be written down. In science, only the numbers that have significance (derived from measurement) are written.
- **Rule 1:** Non-zero digits are always significant. Number like 26.38 would have four significant figures and 7.94 would have three. The problem comes with numbers like 0.00980 or 28.09.
- **Rule 2:** Any zeros between two significant digits are significant. *e.g.* 406 have 3 significant figures.
- **Rule 3:** A final zero or trailing zeros in the decimal portion only are significant. *e.g.* 0.00500 m only three number are significant.
The zero at left of non-zero and after decimal point are not significant figures.
Another way the number 0.00500 m can be written in scientific notation (in power of 10) is

$$0.00500 \text{ m} = 5.00 \times 10^{-3} \text{ m} = 5.00 \times 10^{-1} \text{ cm}$$

$$= 5.00 \times 10^{-6} \text{ km}$$
 The power 10 is not considered or irrelevant in significant figures.
- **Rule 4:** Trailing zeros in a whole number are not significant. *e.g.* 25,000 has two significant figures.

Example

- 0.009 g → has one significant figure and can be written as 9×10^{-3} g.
- 6.032 Nm⁻² → has four significant figures.
- 0.000507 m² → has three significant figures.
- When some value is recorded on the basis of some actual measurement, the zeros on the right of last non-zero digit become significant. For example, $m = 100$ kg has three significant figures.

Rounding off

- **Rule 1:** If the digit to be dropped is less than 5, then the preceding digit is left unchanged. *e.g.* 8.22 is rounded off to 8.2.

- **Rule 2:** If the digit to be dropped is more than 5, then the preceding digit is raised by one.
e.g. $x = 6.87$ is rounded off to 6.9.
- **Rule 3:** If the digit to be dropped is 5 followed by digit other than zero, then the preceding digit is raised by one.
e.g. 7.851 is rounded off to 7.9.
- **Rule 4:** If the digit to be dropped is 5 or 5 followed by zero, then preceding digit is left unchanged, if it is even.
e.g. 5.250 rounding off to 5.2.
- **Rule 5:** If the digit to be dropped is 5 or 5 followed by zeros, then the preceding digit is raised by one, if it is odd.
e.g. 3.750 is rounded off to 3.8.
- **Accuracy** is the extent to which a reported measurement approaches the true value of the quantity measured.

Absolute error

- This error in the measurement of a quantity is the magnitude of the difference between the true value and the measured value of the quantity.
Let in some experiment on physical quantity is measured n times. Let the measured values be a_1, a_2, \dots, a_n . The arithmetic mean of these value is

$$a_m = \frac{a_1 + a_2 + \dots + a_n}{n} \quad \text{or} \quad a_m = \frac{1}{n} \sum_{i=1}^n a_i$$

a_m is considered as true value of the quantity, if the true value of that quantity is not known.

- The absolute error in the measured values of quantity are

$$\Delta a_1 = a_m - a_1$$

$$\Delta a_2 = a_m - a_2$$

.....

.....

.....

$$\Delta a_n = a_m - a_n$$

The absolute error may be positive in certain cases and negative in certain other cases.

Mean absolute error

It is the arithmetic mean of the magnitude of absolute errors in all the measurements of the quantity.

$$\overline{\Delta a} = \frac{|\Delta a_1| + |\Delta a_2| + \dots + |\Delta a_3|}{n}$$

$$\overline{\Delta a} = \frac{1}{n} \sum_{i=1}^n |\Delta a_i|$$

Hence the final result of measurement may be written as

$$a = a_m \pm \overline{\Delta a} .$$

Relative error or fractional error

$$\text{Relative error} = \frac{\text{mean absolute error}}{\text{mean value}} = \frac{\overline{\Delta a}}{a_m}$$

$$\text{Percentage error} = \frac{\overline{\Delta a}}{a_m} \times 100\%$$

Propagation or combination of errors

- **Error in sum of quantities**

Let $x = a + b$

Let Δa = absolute error in measurement of a

Let Δb = absolute error in measurement of b

The maximum absolute error in x is

$$\Delta x = \pm (\Delta a + \Delta b)$$

- **Error in difference of quantities**

Let $x = a - b$

The maximum absolute error in x is

$$\Delta x = \pm (\Delta a + \Delta b)$$

- **Error in product of quantities**

$x = a \times b$

Maximum possible value of (or maximum fractional error or relative error in product)

$$\frac{\Delta x}{x} = \pm \left(\frac{\Delta a}{a} + \frac{\Delta b}{b} \right)$$

- **Error in division of quantities**

Let $x = \frac{a}{b}$

The maximum value of fractional or relative error in division of quantities is

$$\frac{\Delta x}{x} = \pm \left(\frac{\Delta a}{a} + \frac{\Delta b}{b} \right)$$

- **Error in quantity raised to some power**

Let $x = \frac{a^n}{b^m}$

The fraction error or relative error.

$$\frac{\Delta x}{x} = \pm \left(n \frac{\Delta a}{a} + m \frac{\Delta b}{b} \right)$$

- The initial and final temperatures of water as recorded by an observer are $(40.6 \pm 0.2)^\circ\text{C}$ and $(78.3 \pm 0.3)^\circ\text{C}$. The rise in temperature with proper error limit is given by :

$$\text{Rise in temperature} = \theta = \theta_2 - \theta_1 = 78.3 - 40.6 = 37.7^\circ\text{C} \quad \Delta\theta = (\Delta\theta_1 + \Delta\theta_2)$$

$$= \pm (0.2 + 0.3) = \pm 0.5^\circ\text{C}$$

Hence rise in temperature = $(37.7 \pm 0.5)^\circ\text{C}$.

- Any **order of magnitude** is an exponential change of plus-or-minus 1 in the value of a quantity or unit. The term is generally used in conjunction with power-of-10 scientific notation.

- In base 10, the most common numeration scheme worldwide, an increase of one order of magnitude is the same as multiplying a quantity by 10. An increase of two orders of magnitude is the equivalent of multiplying by 100 or 10^2 . In general, an increase of n orders of magnitude is the equivalent of multiplying a quantity of 10^n . This, 2315 is one order of magnitude larger than 231.5, which in turn is one order of magnitude larger than 23.15.
- For smaller value, a decrease of one order of magnitude is the same as multiplying a quantity by 0.1. A decrease of two orders of magnitude is the equivalent of multiplying by 0.01 or 10^{-2} . In general, a decrease of n orders of magnitude is equivalent of multiplying a quantity by 10^{-n} .
- In the Standard International (SI) System of Units, most quantities can be expressed in multiple or fractional terms according to the order of magnitude. For example attaching the prefix “kilo” to a unit increases the size of the unit by three orders of magnitude, or one thousand (10^3). Attaching the prefix “micro” to a unit decreases the size of the unit by six orders of magnitude, the equivalent of multiplying it by one millionth (10^{-6}). Scientists and engineers have designated prefix multipliers from septillionths (10^{-24}) to septillions (10^{24}), a span of 48 orders of magnitude.

Trigonometric identities

- **Reciprocal identities**

$$\sin u = \frac{1}{\operatorname{cosec} u}, \quad \cos u = \frac{1}{\sec u}, \quad \tan u = \frac{1}{\cot u}$$

$$\operatorname{cosec} u = \frac{1}{\sin u}, \quad \sec u = \frac{1}{\cos u}, \quad \cot u = \frac{1}{\tan u}$$

- **Pythagorean identities**

$$\sin^2 u + \cos^2 u = 1, \quad 1 + \tan^2 u = \sec^2 u$$

$$1 + \cot^2 u = \operatorname{cosec}^2 u$$

- **Quotient identities**

$$\tan u = \frac{\sin u}{\cos u}, \quad \cot u = \frac{\cos u}{\sin u}$$

- **Co-function identities**

$$\sin\left(\frac{\pi}{2} - u\right) = \cos u, \quad \cos\left(\frac{\pi}{2} - u\right) = \sin u$$

$$\tan\left(\frac{\pi}{2} - u\right) = \cot u, \quad \operatorname{cosec}\left(\frac{\pi}{2} - u\right) = \sec u$$

$$\sec\left(\frac{\pi}{2} - u\right) = \operatorname{cosec} u, \quad \cot\left(\frac{\pi}{2} - u\right) = \tan u$$

- **Even-odd identities**

$$\sin(-\theta) = -\sin\theta, \quad \cos(-\theta) = \cos\theta$$

$$\tan(-\theta) = -\tan\theta, \quad \operatorname{cosec}(-\theta) = -\operatorname{cosec} \theta$$

$$\sec(-\theta) = \sec\theta, \quad \cot(-\theta) = -\cot\theta$$

- **Sum-difference formulae**

$$\sin(u \pm v) = \sin u \cos v \pm \cos u \sin v$$

$$\cos(u \pm v) = \cos u \cos v \mp \sin u \sin v$$

$$\tan(u \pm v) = \frac{\tan u \pm \tan v}{1 \mp \tan u \tan v}$$

- **Double angle formulae**

$$\sin(2u) = 2 \sin u \cos u$$

$$\cos(2u) = \cos^2 u - \sin^2 u = 2 \cos^2 u - 1 = 1 - 2 \sin^2 u$$

$$\tan(2u) = \frac{2 \tan u}{1 - \tan^2 u}$$

- **Power-reducing/half angle formulae**

$$\sin^2 u = \frac{1 - \cos(2u)}{2} \quad ; \quad \cos^2 u = \frac{1 + \cos(2u)}{2}$$

$$\tan^2 u = \frac{1 - \cos(2u)}{1 + \cos(2u)}$$

- **Sum-to-product formulae**

$$\sin u + \sin v = 2 \sin\left(\frac{u+v}{2}\right) \cos\left(\frac{u-v}{2}\right)$$

$$\sin u - \sin v = 2 \cos\left(\frac{u+v}{2}\right) \sin\left(\frac{u-v}{2}\right)$$

$$\cos u + \cos v = 2 \cos\left(\frac{u+v}{2}\right) \cos\left(\frac{u-v}{2}\right)$$

$$\cos u - \cos v = -2 \sin\left(\frac{u+v}{2}\right) \sin\left(\frac{u-v}{2}\right)$$

- **Product-to-sum formulae**

$$\sin u \sin v = \frac{1}{2} [\cos(u-v) - \cos(u+v)]$$

$$\cos u \cos v = \frac{1}{2} [\cos(u-v) + \cos(u+v)]$$

$$\sin u \cos v = \frac{1}{2} [\sin(u+v) + \sin(u-v)]$$

$$\cos u \sin v = \frac{1}{2} [\sin(u+v) - \sin(u-v)]$$

Measurement

- The mass, length and time in the physical world have variations from atomic to astronomical range. Measurements are an integral part of all advancements in modern science and technology. Extent of uncertainty is simultaneously taken into account while reporting the results of research and exploration.

Measurement of length

- The Indian national standards of seven base units are maintained at National Physical Laboratory (NPL), New Delhi.
- The standard of length (metre) is realised by employing a stabilised helium-neon laser as a source of light.
- Very small distances such as inter-molecular distances, size of molecules, radius of atom can be measured by electron microscope. Modern science has developed tunneling microscopes to resolve microscopic distances. Rutherford developed scattering method to measure distance of closest approach which is of the order of 10^{-14} m.
- Very large distances such as the distance of a star from earth can be measured with the help of angular measurements or parallax methods. Sextant can measure height of mountains. Radar signal echo method or optical Doppler shift method provide measurements of diameters of moon and star.
- The following table displays the large variation in terms of order of magnitude of length.

1.	Diameter of proton	10^{-15} m
2.	Diameter of nucleus	10^{-14} m
3.	Diameter of hydrogen atom	10^{-10} m
4.	Height of human being	10^0 m
5.	Length of cricket field	10^2 m
6.	Height of Mount Everest	10^4 m
7.	Diameter of earth	10^7 m
8.	Diameter of sun	10^9 m
9.	Distance of sun from earth	10^{11} m
10.	Diameter of our galaxy	10^{21} m.

Measurement of mass

- The Indian national standard of mass is a copy No. 57 of the International prototype kilogram supplied by the International Bureau of Weights and Measures (BIPM).
- Science differentiates between the inertial mass and the gravitational mass.
- Inertial mass (m) = force/acceleration. It can be measured with the help of inertia balance.
- Gravitational mass of a body determines the gravitational pull due to earth acting upon the body. It can be measured with the help of a common balance. In order to measure the weight of a body, a spring balance is used.
- The following table displays the huge variation in terms of order of magnitude of mass:

1.	Electron	10^{-30} kg
2.	Proton	10^{-27} kg
3.	Atom	10^{-25} kg
4.	Human being	10^2 kg
5.	Hippopotamus	10^3 kg
6.	Moon	10^{23} kg
7.	Earth	10^{25} kg
8.	Star	10^{30} kg
9.	Galaxy	10^{42} kg
10.	Universe	10^{55} kg.

Measurement of time

- The national standard of time interval, second as well as frequency, is maintained through four cesium atomic clocks mentioned at NPL.
- The standard maintained at NPL is linked to different users in a variety of ways. This process is known as dissemination. Time is disseminated through TV, radio, special telephone service for day-to-day requirements. For high level of accuracy there is a satellite-based time dissemination service which utilized the Indian Satellite INSAT.
- The following table displays the low to high range of variation of time.

1.	Time for proton to revolve in nucleus	10^{-22} s
2.	Period of atomic vibration	10^{-15} s
3.	Time taken by atom to emit light	10^{-9} s
4.	Time between heart beats	10^0 s
5.	Time during which sun light reaches earth	10^3 s
6.	Time during which earth rotates on its orbit (day)	10^5 s
7.	Time during which earth revolves around sun (year)	10^7 s
8.	Human life span	10^9 s.

Units

- In the **System International**, length(m), mass(kg), time(s), electric current(A), thermodynamic temperature(K), luminous intensity(cd) and quantity of matter(mol) are considered as fundamental quantities. In this system, plane angle and solid angle are considered as supplementary quantities.
- The quantities that are derived using the fundamental quantities are called **derived quantities**. For example speed, volume, acceleration, force, momentum, etc.
- The units, that are used to measure the fundamental quantities are known as **fundamental units**.
- The units, that are used to measure the derived quantities are known as derived units *e.g.* metre², newton, cubic metre, erg, watt, etc.
- Some more quantities which are found to be fundamental in nature are added to the existing list of fundamental quantities. The system consisting of all fundamental quantities is known as “System International” and units are called SI units.
- Units should not be expressed in capital letters. They should be written as newton, joule, watt, etc.
- Units can be expressed in full or by approved symbols.
- Units must be expressed in singular form. Example: 11 metre, 26 newton, 6 joule, etc.
- **Symbols of units** : When a unit is named after a scientist, the symbol is a capital letter. For other units, the symbol is not a capital letter. Thus symbol for kelvin, the unit of temperature is K. Similarly J (joule), N (newton), W (watt), P (pascal), C (coulomb), A (ampere), F (faraday), H (henry), V (volt), Wb (weber), T (tesla), Gs (gilbert), Ω (ohm), S (siemen) represent other units. Correct symbol for gram is g, for kilogram is kg, for metre is m.
- **Single solidus** : In a symbol, more than one solidus should not be used. Acceleration should not be expressed as m/s/s. It should be written as ms^{-2} or m/s^2 . The index form ms^{-2} is, however, preferred.

- **No full stop after symbol.** Volume should be written as cc and not as c.c.
- **Derived units and equivalences**

Derived unit	Quantity	Equivalence
quintal	Mass	1 q = 100 kg
metric ton	Mass	1 t = 1000 kg
atomic mass unit	Mass	1 amu = 1.66×10^{-27} kg
fermi	Length	1 f = 10^{-15} m
X-ray unit	Length	1 Xu = 10^{-13} m
angstrom unit	Length	1 Å = 10^{-10} m
micron	Length	1 μ m = 10^{-6} m
astronomical unit	Length	1 AU = 1.5×10^{11} m
light year	Length	1 ly = 9.46×10^{15} m
parallactic second	Length	1 pc = 3.26 ly
parsec	Length	1 pc = 3×10^{16} m
mile	Length	1 mile = 1.61 km
nautical mile	Length	1 n mile = 1852 m
shake	Time	1 shake = 10^{-8} second
acre	Area	4047 sq. m
hectare	Area	10^4 sq. m = 2.47 acre
barn	Area	10^{-28} m ²
newton (N)	Force	10^5 dyne
pascal (P)	Pressure	1 Nm ⁻²
bar	Pressure	1 atmosphere or 10^5 pascal
torr	Pressure	133.3 pascal
gal	Acceleration	10^{-2} ms ⁻²
joule (J)	Energy	1 Nm = 10^7 erg = 0.24 cal
eV	Energy	1.6×10^{-19} J = 1.6×10^{-12} erg
horse power	Power	746 watt = 0.746 kW

Dimensions

- The **dimensions** of a physical quantity are the powers to which the fundamental units are raised to obtain the unit of that quantity.
- Angle and ratio do not have dimensions.
- The dimensional equations are used
 - (a) to verify whether an equation connecting physical quantities is correct or not.
 - (b) to find the relation between systems of units of the same physical quantity.
 - (c) to derive equations connecting physical quantities.
- The dimensional methods are applicable to equations connecting physical quantities alone.
- The dimensional methods are applicable to equations involving the three fundamental quantities only.
- The proportionality constants are to be found experimentally.
- How to obtain a dimensional formula?
 - (a) From the definition or from the defining equation:

$$F = \text{Force} = ma$$

$$= \text{mass} \times \frac{\text{Velocity change}}{\text{Time}} = M^1 L^1 T^{-2}.$$

(b) From a knowledge of the unit:

$$\text{Planck's constant} = \text{joule} \cdot \text{sec} = M^1 L^2 T^{-2} T^1 = M^1 L^2 T^{-1}.$$

(c) From a formula in which the required quantity appears:

$$Q = KA \frac{(T_2 - T_1)}{L} \cdot t ; K = \frac{QL}{A(T_2 - T_1)t}$$

$$K = \frac{M^1 L^2 T^{-2} \cdot L}{L^2 K^{-1} T^1} = M^1 L^1 T^{-3} K^{-1}.$$

• **Important uses of dimensions illustrated**

(a) Conversion from one system to the other:

$$\text{Ex: Force} = \frac{\text{kg} \cdot \text{m} \cdot \text{sec}^{-2}}{\text{g} \cdot \text{cm} \cdot \text{sec}^{-2}} = 1000 \times 100 = 10^5$$

$$1 \text{ N} = 10^5 \text{ dyne}.$$

(b) Investigating how the unit of a derived quantity change when the fundamental units L, M, T are altered.

Ex: If L, M and T are doubled, what happens to the unit of power.

$$P = \text{Power} = \frac{M^1 L^2}{T^3}$$

$$P_1 = \frac{M_1^1 L_1^2}{T_1^3} = \frac{(2M)^1 (2L)^2}{(2T)^3} = \frac{2 \times 4M^1 L^2}{8 T^3} = P.$$

- If L represents inductance, C represents capacitance, R represents resistance and q represents the charge, then
 - (i) L/R , RC , \sqrt{LC} have the dimensions of time
 - (ii) R/L , $1/RC$, $1/\sqrt{LC}$ have dimensions of frequency.
 - (iii) q^2/C , LP , qV , V^2C , all have dimensions of energy.
- If R is resistance, I is current, V is potential difference and t is time, then
 - (i) VI , V^2/R , $I^2 R$ have the dimensions of power.
 - (ii) $VI t$, $\frac{V^2 t}{R}$, $I^2 R t$ have the dimensions of energy.
- If m is mass, s is specific heat, $\Delta\theta$ is change in temperature, L is latent heat, P is pressure, V is volume, T is temperature and R is gas constant, then $ms \Delta\theta$; mL ; PV ; RT all have the same dimensions of energy [$M^1 L^2 T^{-2}$].
- The principle of homogeneity of dimensions is used in checking the correctness of formulae, and also in the derivation of formulae.
- Only like quantities having the same dimensions can be added to or subtracted from each other.
- The order of accuracy obtained in adopting atomic standards of length and time, as detailed earlier is 1 part in 10^9 .

- Planck's constant has the same dimensional formula as angular momentum, *i.e.* $[M^1 L^2 T^{-1}]$.
- Thermal capacity, Boltzmann constant, entropy have the same dimensions, *i.e.* $[ML^2 T^{-2} K^{-1}]$.
- Work, energy, kinetic energy, potential energy, couple, moment of a force, torque, internal energy, heat energy, electron volt, kilowatt, hour, etc. all have the same dimensional formula $[M^1 L^2 T^{-2}]$.
- The three coefficients of elasticity, stress, pressure have the same dimensions, *i.e.* $[M^1 L^{-1} T^{-2}]$.
- Strain, refractive index, relative density, angle, solid angle, trigonometrical ratios, phase, relative permittivity and relative permeability-all are dimensionless.
- Surface tension, surface energy, spring constant and force gradient have the same dimensional formula, *i.e.* $[M^1 L^0 T^{-2}]$.
- Force, thrust and weight have the same dimensional formula, *i.e.* $[M^1 L^1 T^{-2}]$.
- Inertia and mass have the same dimensional formula.
- Relative velocity also has the dimensions of velocity.
- Distance travelled in n th second has the dimensions of velocity.

A decorative symbol for the end of the text, consisting of the word "End" in a stylized, cursive font, enclosed within a circular, swirling frame.

kinematics and vectors

- Mechanics can be divided under two branches- (i) **statics** which deals with the study of stationary objects and (ii) **dynamics** which deals with the study of moving objects.
- An object is said to be at **rest** if it does not change its position with time with respect to its surroundings.
- An object is said to be in **motion** if it changes its position with time, with respect to its surroundings.
- **Rest and motion are relative.** It means an object observed in one frame of reference may be at rest, the same object can be in motion in another frame of reference.
- An object can be considered as a point object if during motion in a given time, it covers a distance much greater than its own size.
- The motion of an object is said to be **one dimensional motion** if only one out of the three coordinates specifying the position of the object changes with respect to time. In such a motion, an object moves along a straight line.
- The motion of an object is said to be **two dimensional motion** if two out of the three coordinates specifying the position of the object change with respect to time. In such a motion, the object moves in a plane.
- The motion of an object is said to be **three dimensional motion** if all the three coordinates specifying the position of the object change with respect to time. In such a motion, the object moves in a space.
- The **distance** travelled by an object is defined as the length of the actual path traversed by an object during motion in a given interval of time. Distance is a scalar quantity. Its value can never be zero or negative, during the motion of an object.
- The **displacement** of an object in a given interval of time is defined as the change in the position of the object along a particular direction during that time and is given by the straight line joining the initial position to final position. The displacement of an object can be positive, zero or negative. The displacement of an object between two positions has a unique value, which is the shortest distance between them. The magnitude of the displacement of an object in a given time interval can be equal or less than the actual distance travelled but never greater than the distance travelled.
- For a stationary body, the displacement-time graph is a straight line (AB) parallel to time axis.

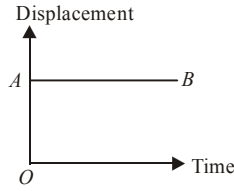

- When a body is moving with a constant velocity, then displacement-time graph will be a straight line.

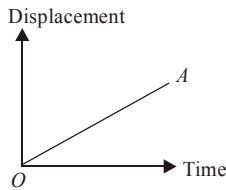

- When a body is moving with a constant acceleration, the displacement-time graph is a parabola.

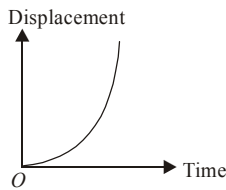

- When a body is moving with a constant retardation, the displacement-time graph is a curve which bends downwards.

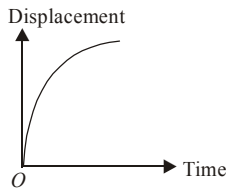

- When a body is moving with infinite velocity, the time-displacement curve is a straight line AB parallel to displacement axis. But such motion of a body is never possible.

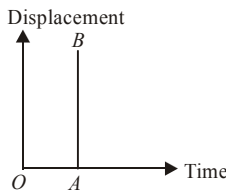

- The **speed** of an object is defined as the time rate of change of position of the object in any direction,
i.e. speed = distance travelled/(time taken).
 Speed is a scalar quantity. It can be zero or positive but never negative.

$$v = (s/t) \text{ m/s.}$$

- An object is said to be moving with a **uniform speed**, if it covers equal distances in equal intervals of time, howsoever small these intervals may be.
- An object is said to be moving with a **variable speed** if it covers equal distances in unequal intervals of time or unequal distances in equal intervals of time, howsoever small these intervals may be.
- The **average speed** of an object for the given motion is defined as the ratio of the total distance travelled by the object to the total time taken.

$$i.e. \text{ Average speed} = \frac{\text{total distance travelled}}{\text{total time taken}}$$

- **Average speed-harmonic mean** : When a body travels equal distance with speeds v_1 and v_2 , the average speed (v) is the harmonic mean of the two speeds.

$$\frac{2}{v} = \frac{1}{v_1} + \frac{1}{v_2}.$$

- **Average speed and average of speeds**: When a body travels for equal time with speeds v_1 and v_2 , the average speed v is the arithmetic mean of the two speeds.

$$v = \frac{v_1 + v_2}{2}.$$

This speed is same as average of speeds.

- The speed of an object at a given instant of time is called its **instantaneous speed**.

$$v = \frac{ds}{dt}$$

- The **velocity** of an object is defined as the time rate of change of displacement of the object.

i.e. velocity = displacement/time taken.

$$\text{velocity } (\bar{v}) = \frac{\text{displacement}}{\text{time}} = \frac{d\bar{x}}{dt} \quad \text{or,} \quad \bar{v} = \frac{\bar{x}_2 - \bar{x}_1}{t_2 - t_1} \text{ m/s.}$$

where \bar{x}_1 and \bar{x}_2 are the displacement of an object at instants t_1 and t_2 .

The velocity is a vector quantity. The velocity of an object can be positive, zero or negative.

- If an object undergoes equal displacements in equal intervals of time, it is said to be moving with a **uniform velocity**. If an object undergoes unequal displacements in equal intervals of time or equal displacements in unequal intervals of time, it is said to be moving with a **variable velocity**.
- The average velocity of an object is equal to the ratio of the total displacement, to the total time interval for which the motion takes place.

$$\text{Average velocity} = \frac{\text{total displacement}}{\text{total time}}.$$

- The velocity of an object at a given instant of time is called **instantaneous velocity**.

$$\bar{v} = d\bar{x} / dt$$

When a body is moving with a uniform velocity, its instantaneous velocity = average velocity = uniform velocity.

- When a body is moving with a constant velocity, the velocity-time graph is a straight line AB parallel to time axis.

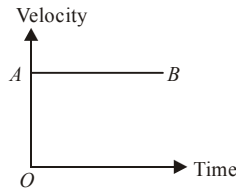

- When a body is moving with a constant acceleration and its initial velocity is zero, the velocity-time graph is an oblique straight line, passing through origin.

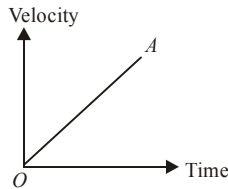

- When a body is moving with a constant acceleration and its initial velocity is not zero, the velocity-time graph is an oblique straight line AB not passing through origin.

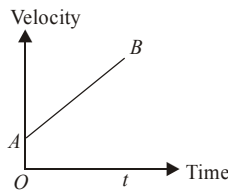

- When a body is moving with a constant retardation and its initial velocity is not zero, the velocity-time graph is an oblique straight line AB , not passing through origin.

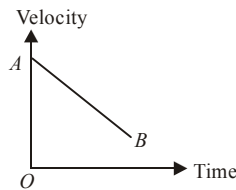

- When a body is moving with increasing acceleration, the velocity-time graph is a curve which bend upwards.

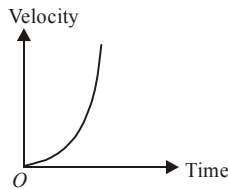

- When a body is moving with decreasing acceleration, the velocity-time graph is a curve is similar to the one shown here.

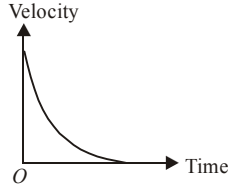

- Slope of displacement-time graph gives **average velocity**.
- Slope of velocity-time graph gives **average acceleration**.
- The area of velocity-time graph with time axis gives total distance covered by the body.
- When a body is dropped freely from the top of the tower and another body is projected horizontally from the same point, both will reach the ground at the same time.
- In case of motion under gravity, motion is independent of the mass of the body, *i.e.* if a heavy and light body are dropped from the same height, they reach the ground simultaneously with the same speed because time taken by the body to reach the ground $= \sqrt{2h/g}$.

- **Relative velocity** : The relative velocity of one body with respect to another body is the velocity with which one body moves with respect to another body. If \vec{v}_A and \vec{v}_B are the velocities of two bodies A and B , and θ is the angle between them, then relative velocity of body A with respect to B is given by

$$\vec{v}_{AB} = \vec{v}_A - \vec{v}_B$$

$$\text{where, } |\vec{v}_{AB}| = \sqrt{|\vec{v}_A|^2 + |\vec{v}_B|^2 + 2|\vec{v}_A||\vec{v}_B|\cos(180^\circ - \theta)}$$

$$= \sqrt{|\vec{v}_A|^2 + |\vec{v}_B|^2 - 2|\vec{v}_A||\vec{v}_B|\cos\theta}$$

$$\text{and } \tan\beta = \frac{|\vec{v}_B|\sin(180^\circ - \theta)}{|\vec{v}_A| + |\vec{v}_B|\cos(180^\circ - \theta)} = \frac{|\vec{v}_B|\sin\theta}{|\vec{v}_A| - |\vec{v}_B|\cos\theta}$$

Here, β is the angle which \vec{v}_{AB} makes with the direction of \vec{v}_A .

- If the two bodies A and B are moving in opposite directions with velocities \vec{u} and \vec{v} then, relative velocity of A with respect to B is equal to $(\vec{u} + \vec{v})$.
- If the two bodies A and B are moving with velocities \vec{u} and \vec{v} in the same direction, then relative velocity of A with respect to B is equal to $(\vec{u} - \vec{v})$.
- If rain drops are falling vertically with a velocity \vec{v} and a person is walking horizontally with a velocity \vec{u} , then he should hold an umbrella at angle θ with vertical given by $\tan\theta = \frac{|\vec{u}|}{|\vec{v}|}$, to prevent himself from being wet.

- The **acceleration** of an object is defined as the time rate of change of velocity of the object,

i.e. acceleration = change in velocity/time taken.

Acceleration is a vector quantity. Acceleration is positive, if the velocity is increasing and is negative if velocity is decreasing. The negative acceleration is called retardation or deceleration.

$$\bar{a} = \frac{\bar{v}_2 - \bar{v}_1}{t_2 - t_1}$$

- If the velocity of an object changes by equal amounts in equal intervals of time, it is said to be moving with a **uniform acceleration**. If the velocity of an object changes by unequal amounts in equal intervals of time, it is said to be moving with a **variable acceleration**.
- The **average acceleration** of an object for a given motion is defined as the ratio of the total change in velocity of the object during motion to the total time taken.

i.e. average acceleration = $\frac{\text{total change in velocity}}{\text{total time taken}}$

- The acceleration of an object at a given instant or at a given point of motion is called its **instantaneous acceleration**. It is defined as the first time derivative of velocity at a given instant or it is also equal to the second time derivative of the position of the object at a given instant.

i.e. instantaneous acceleration,

$$\bar{a} = \lim_{\Delta t \rightarrow 0} \frac{\Delta \bar{v}}{\Delta t} = \frac{d\bar{v}}{dt} = \frac{d^2\bar{x}}{dt^2}$$

- Negative acceleration is known as **retardation**. It indicates that velocity of the object is decreasing with respect to time.
- When a body is moving with constant acceleration, the acceleration-time graph is a straight line AB parallel to time axis.

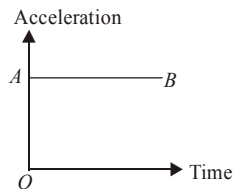

- When a body is moving with constant increasing acceleration, the acceleration-time graph is a straight line OA .

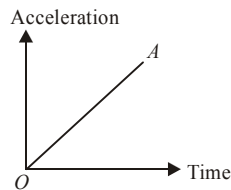

- When a body is moving with constant decreasing acceleration, the acceleration-time graph is a straight line.

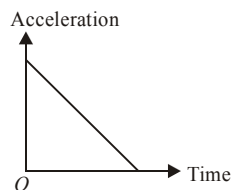

- **Equations of motion** for uniformly accelerated motion along a straight line.

$$(i) v = u + at \qquad (ii) s = ut + \frac{1}{2}at^2$$

$$(iii) v^2 = u^2 + 2as \qquad (iv) s_n = u + \frac{a}{2}(2n-1)$$

where u is initial velocity, v is final velocity, a is uniform acceleration, s is distance travelled in time t , s_n is distance covered in n^{th} second. These equations are not valid if the acceleration is non-uniform.

- **Scalars** : These are those quantities which have only magnitudes but no direction. For example mass, length, time, speed, work, temperature, etc.
- **Vectors** : These are those quantities which have magnitude as well as direction. For example displacement, velocity, acceleration, force, momentum, etc.
- **Tensor** : A physical quantity which has different values in different directions at the same point is called a tensor. Pressure, stress, moduli of elasticity, moment of inertia, radius of gyration, refractive index, wave velocity, dielectric constant, conductivity, resistivity and density are a few examples of tensor. Magnitude of tensor is not unique.
- **Representation of a vector** :
 - A vector is represented by a straight line.
 - It carries an arrow head at one extremity.
 - The arrow head represents direction of vector.
 - The length of line represents magnitude of vector.
 - Tail is the point from which the vector originates.
 - Head is a point at which the vector ends.
- **Addition of vectors - Properties** :
 - (a) Vector addition is commutative, *i.e.* $\vec{A} + \vec{B} = \vec{B} + \vec{A}$.
 - (b) Vector addition is associative. It means that

$$\vec{A} + (\vec{B} + \vec{C}) = \vec{B} + (\vec{C} + \vec{A}) = \vec{C} + (\vec{A} + \vec{B}) .$$
 - (c) Vector addition is distributive. It means that

$$m(\vec{A} + \vec{B}) = m\vec{A} + m\vec{B}$$

$$(m + n)\vec{A} = m\vec{A} + n\vec{A}$$
 - (d) The maximum value of vector addition is $(A + B)$.
 - (e) The minimum value of vector addition is $(A - B)$.
- **Rotation of a vector** :
 - (a) If the frame of reference is rotated or translated, the given vector does not change. The components of the vector may, however, change.
 - (b) If a vector is rotated through an angle θ , which is not an integral multiple of 2π , the vector changes.
- **Direction cosines of vector \vec{A}** :

$$\cos \alpha = \frac{A_x}{A}, \quad \cos \beta = \frac{A_y}{A}, \quad \cos \gamma = \frac{A_z}{A}$$

$$\cos^2 \alpha + \cos^2 \beta + \cos^2 \gamma = 1.$$

- Graphically a vector A is represented by a directed segment of a straight line, whose direction is that of the vector it represents and whose length corresponds to the magnitude $|\vec{A}|$ of \vec{A} .
- A **unit vector** of a given vector \vec{A} is a vector of unit magnitude and has the same direction as that of the given vector. A unit vector of \vec{A} is written as \hat{A} , where $\hat{A} = \vec{A} / |\vec{A}|$. A unit vector is unitless and dimensionless vector and represents direction only.
- The symbol $\hat{i}, \hat{j}, \hat{k}$ represent unit vectors along x, y and z directions of coordinate axes respectively.
- Null vector** is a vector which has zero magnitude and an arbitrary direction. It is represented by $\vec{0}$ and is also known as **zero vector**. Velocity of a stationary object, acceleration of an object moving with uniform velocity and resultant of two equal and opposite vectors are the examples of null vector.
- Equal vectors** : Two vectors are said to be equal if they have equal magnitude and same direction.
- A **negative vector** of a given vector is a vector of same magnitude but acting in a direction opposite to that of the given vector. The negative vector of \vec{A} is represented by $-\vec{A}$.
- A vector whose initial point is fixed is called a **localised vector** and whose initial point is not fixed is called **non-localised vector**.
- Multiplication of a vector by a real number** : When a vector \vec{A} is multiplied by a real number n , it becomes another vector $n\vec{A}$. Its magnitude becomes n times the magnitude of \vec{A} . Its direction is same or opposite as that of \vec{A} , according as n is positive or negative real number. The unit of $n\vec{A}$ is the same as that of \vec{A} .
- Multiplication of a vector by a scalar** : When a vector \vec{A} is multiplied by a scalar S , it becomes a vector $S\vec{A}$, whose magnitude is S times the magnitude of \vec{A} and it acts along the direction of \vec{A} . The unit of $S\vec{A}$ is different from the unit of vector \vec{A} .
- For the **addition of two vectors**, represent these two vectors by arrowed lines using the same suitable scale. Displace the second vector such that its tail coincides with the head of the first vector. Then the single vector, drawn from the tail of the first vector to the head of the second vector represents the resultant vector.
- Triangle law of vectors** : If two vectors acting simultaneously at a point are represented in magnitude and direction by two sides of a triangle taken in the same order, then their resultant is represented by the third side of the triangle taken in the opposite order.

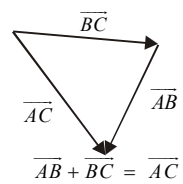

According to triangle law of vector addition.

$$\vec{P} + \vec{Q} = \vec{R} \quad \text{or} \quad \vec{AB} + \vec{BC} = \vec{AC}$$

$$\text{or} \quad \vec{AB} + \vec{BC} + \vec{CA} = \vec{AC} + \vec{CA}$$

(adding vector \vec{CA} to both sides of the equation).

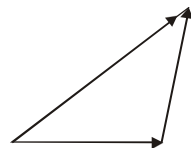

$$\text{or } \vec{AB} + \vec{BC} + \vec{CA} = \vec{AC} - \vec{AC} \quad \left[\because \vec{CA} = -\vec{AC} \right]$$

$$= 0.$$

- **Parallelogram law of vectors:** It states that if two vectors acting on a particle at the same time be represented in magnitude and direction by the two adjacent sides of a parallelogram drawn from a point, their resultant vector is represented in magnitude and direction by the diagonal of the parallelogram drawn from the same point.

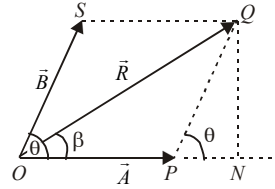

If \vec{R} is the resultant of \vec{A} and \vec{B} , then

$$R = \sqrt{A^2 + B^2 + 2AB \cos \theta} \quad \text{and} \quad \tan \beta = \frac{B \sin \theta}{A + B \cos \theta}$$

Note : The magnitude of the resultant vector is maximum if the two vectors are acting in the same direction and is minimum if the two vectors are acting in the opposite directions.

- **Polygon law of vectors :** It states that if number of vectors acting on a particle at a time are represented in magnitude and direction by the various sides of an open polygon taken in same order, their resultant vector is represented in magnitude and direction by the closing side of the polygon taken in opposite order. In fact polygon law of vectors is the outcome of triangle law of vectors.
- **Subtraction of vectors :** Subtraction of a vector \vec{B} from a vector \vec{A} is defined as the addition of vector $-\vec{B}$ (negative of vector \vec{B}) to vector \vec{A} .

$$\text{Thus, } \vec{A} - \vec{B} = \vec{A} + (-\vec{B})$$

- **Rectangular components of a vector in a plane**

When a vector is splitted into two component vectors at right angles to each other, the component vectors are called rectangular components of a vector. If \vec{A} makes an angle θ with x -axis and \vec{A}_x and \vec{A}_y are the rectangular components of \vec{A} along x -axis and y -axis respectively, then

$$\vec{A} = \vec{A}_x + \vec{A}_y = A_x \hat{i} + A_y \hat{j}$$

Here, $A_x = A \cos \theta$ and $A_y = A \sin \theta$

$$\therefore A^2 (\cos^2 \theta + \sin^2 \theta) = A_x^2 + A_y^2$$

$$\text{or, } A = (A_x^2 + A_y^2)^{1/2} \quad \text{and} \quad \tan \theta = A_y / A_x.$$

- **Dot product of two vectors :** The dot product of two vectors \vec{A} and \vec{B} is denoted by $\vec{A} \cdot \vec{B}$ and is given by $\vec{A} \cdot \vec{B} = AB \cos \theta$, where θ is the smaller angle between \vec{A} and \vec{B} . The dot product of two vectors is a scalar.
- **Geometrical interpretation of dot product of two vectors :** It is the product of the magnitude of one vector with the magnitude of the component of other vector in the direction of first vector.

- $\vec{A} \cdot \vec{A} = A^2$ or $A = (\vec{A} \cdot \vec{A})^{1/2}$
- $\hat{i} \cdot \hat{i} = \hat{j} \cdot \hat{j} = \hat{k} \cdot \hat{k} = 1$ and $\hat{i} \cdot \hat{j} = \hat{j} \cdot \hat{k} = \hat{k} \cdot \hat{i} = 0$

• **Dot product in cartesian co-ordinates**

$$\begin{aligned} \vec{A} \cdot \vec{B} &= (A_x \hat{i} + A_y \hat{j} + A_z \hat{k}) \cdot (B_x \hat{i} + B_y \hat{j} + B_z \hat{k}) \\ &= A_x B_x + A_y B_y + A_z B_z \\ \vec{A} \cdot \vec{B} &= \vec{B} \cdot \vec{A} \end{aligned}$$

- **Cross product of two vectors :** The cross product of two vectors \vec{A} and \vec{B} is denoted by $\vec{A} \times \vec{B}$. It is a vector whose magnitude is equal to the product of the magnitudes of the two vectors and sine of the smaller angle between them. If θ is smaller angle between \vec{A} and \vec{B} , then $\vec{A} \times \vec{B} = \vec{C} = AB \sin \theta \hat{n}$,

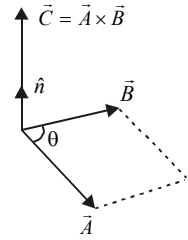

where \hat{n} is a unit vector in the direction of \vec{C} .

- **Geometrical interpretation of vector product of two vectors:** The magnitude of vector product of two vectors is equal
 - (i) to the area of the parallelogram whose two sides are represented by two vectors.
 - (ii) to twice the area of a triangle whose two sides are represented by the two vectors.

• **Properties of cross product**

- (i) Cross product of two parallel vectors is zero. So, $\vec{A} \times \vec{A} = 0$.
- (ii) $\hat{i} \times \hat{i} = 0 = \hat{j} \times \hat{j} = \hat{k} \times \hat{k}$
- (iii) $\hat{i} \times \hat{j} = \hat{k}$, $\hat{j} \times \hat{k} = \hat{i}$, $\hat{k} \times \hat{i} = \hat{j}$
- (iv) $\vec{A} \times \vec{B} = -\vec{B} \times \vec{A}$

• **Cross product in cartesian co-ordinates:**

$$\begin{aligned} \vec{A} \times \vec{B} &= (A_x \hat{i} + A_y \hat{j} + A_z \hat{k}) \times (B_x \hat{i} + B_y \hat{j} + B_z \hat{k}) \\ &= \begin{vmatrix} \hat{i} & \hat{j} & \hat{k} \\ A_x & A_y & A_z \\ B_x & B_y & B_z \end{vmatrix} \\ &= (A_y B_z - A_z B_y) \hat{i} - (A_x B_z - B_x A_z) \hat{j} + (A_x B_y - A_y B_x) \hat{k} \end{aligned}$$

• **Direction of vector cross product :**

- (a) When $\vec{C} = \vec{A} \times \vec{B}$, the direction of \vec{C} is at right angles to the plane containing the vectors \vec{A} and \vec{B} . The **direction** is determined by the right hand screw rule and the right hand thumb rule.
- (b) **Right hand screw rule :** Rotate a right handed screw from first vector (\vec{A}) towards second vector (\vec{B}). The direction in which the right handed screw moves gives the direction of vector \vec{C} .
- (c) **Right hand thumb rule :** Curl the fingers of your right hand from \vec{A} to \vec{B} . Then the direction of the erect thumb will point in the direction of $\vec{A} \times \vec{B}$.

Angular variables

- Angular displacement is the angle which the position vector sweeps out in a given interval of time. It is represented by θ . In SI, the unit of angular displacement is radian (rad). It is a dimensionless quantity.
- **Angular velocity** : The rate of change of angular displacement is called the angular velocity. It is represented as ω . In SI, the unit of angular velocity is radian per second (rad sec^{-1}), its dimensional formula is $[\text{M}^0\text{L}^0\text{T}^{-1}]$.

$$\text{Average angular velocity} = \frac{\Delta\theta}{\Delta t}.$$

$$\text{Instantaneous angular velocity} = \lim_{\Delta t \rightarrow 0} \frac{\Delta\theta}{\Delta t} = \frac{d\theta}{dt} = \omega.$$

Relation between angular and linear velocity $v = r\omega$.

- **Time period** : The time taken to complete one revolution is called the time period. It is denoted by T .
- **Angular acceleration** : The rate of change of angular velocity is called angular acceleration. It is denoted as α and its unit is radian sec^{-2} (rad sec^{-2}). Dimensions are $[\text{T}^{-2}]$.

$$\vec{\alpha} = \frac{d\vec{\omega}}{dt} = \frac{d^2\vec{\theta}}{dt^2}.$$

- Relation between linear acceleration and angular acceleration

$$a = r\alpha.$$

- **Frequency** : The frequency is defined as the number of revolutions completed per second. It is denoted by ν .

$$\nu = \frac{1}{T}. \text{ Its unit is } \text{s}^{-1}.$$

Kinematical equations in circular motion

- (i) The angular velocity of the object after time t is given by $\omega = \omega_0 + \alpha t$.
- (ii) The angular displacement of the object after time t is given by

$$\theta = \omega_0 t + \frac{1}{2} \alpha t^2.$$

- (iii) If the object attains angular velocity ω , while it covers angular displacement θ , then

$$\omega^2 - \omega_0^2 = 2\alpha\theta.$$

CIRCULAR MOTION

- In physics, circular motion is movement of an object with constant speed around in a circle in a circular path or a circular orbit.
- Circular motion involves acceleration of the moving object by a centripetal force which pulls the moving object towards the centre of the circular orbit. Without this acceleration, the object would move inertially in a straight line, according to Newton's first law of motion. Circular motion is accelerated even though the speed is constant, because the velocity of the moving object is constantly changing.

- Examples of circular motion are: an artificial satellite orbiting the earth in geosynchronous orbit, a stone which is tied to a rope and is being swung in circles (cf. hammer throw), a racecar turning through a curve in a racetrack, an electron moving perpendicular to a uniform magnetic field, a gear turning inside a mechanism.
- A special kind of circular motion is when an object rotates around itself. This can be called **spinning motion**.
- Circular motion is characterized by an orbital radius r , a speed v , the mass m of the object which moves in a circle, and the magnitude F of the centripetal force. These quantities are all related to each other through the equations for circular motion.
- The centripetal force can be tension of the string, gravitational force, electrostatic force or Lorentzian. But the centrifugal force $= m\omega^2 r$ or mv^2/r in stable rotation, is equal to the centripetal force in magnitude and acts outwards.
- A centripetal force of magnitude $\frac{mv^2}{r}$ is needed to keep the particle in uniform circular motion.
- Centrifugal force is the force acting away from the centre and is equal in magnitude to the centripetal force.
- For a safe turn the co-efficient of friction between the road and the tyre should be,

$$\mu_s \geq \frac{v^2}{rg}$$
 where v is the velocity of the vehicle
 r is the radius of the circular path
- Angle of banking, $\tan \theta = \frac{v^2}{rg}$ this θ depends on the speed, v and radius of the turn r .
- A cyclist provides himself the necessary centripetal force by leaning inward on a horizontal track.
- The maximum permissible speed for the vehicle is much greater than the optimum value of the speed on a banked road. It is because, friction between road and the tyre of the vehicle also contributes to the required centripetal force.
- Roads are usually banked for the average speed of vehicle passing over them. If μ is the coefficient of friction between the tyres and the road the safe value limit is

$$v = \sqrt{\frac{rg \tan \theta + \mu}{1 - \mu \tan \theta}}$$
- In case of vertical circle the minimum velocity v , the body should possess at the top so that the string does not slack, is \sqrt{gr} .
- The magnitude of velocity at the lowest point with which body can safely go round the vertical circle of radius r is $\sqrt{5gr}$.
- Tension in the string at lowest point $T = 6Mg$.
- The tangent at every point of the circular motion gives the direction of motion in circular motion at that point.

- A car some times overturns while taking a turn. When it overturns it is the inner wheel, which leaves the ground first.
- A car when passes a convex bridge exerts a force on it which is equal to $Mg - \frac{Mv^2}{r}$.
- The driver of a car should brake suddenly rather than taking sharp turn to avoid accident, when he suddenly sees a broad wall in front of him.

Uniform horizontal circular motion

- The instantaneous velocity and displacement act along tangent to the circle at a point.
- The centripetal acceleration and the centripetal force act along radius towards the centre of circle.
- The centripetal force and displacement are at right angles to each other. Hence the work done by the centripetal force is zero.
- Kinetic energy of a particle performing uniform circular motion, in horizontal plane, remains constant.
- The instantaneous velocity of particle and the centripetal acceleration are at right angles to each other. Hence the magnitude of velocity does not change but the direction of velocity changes continuously. It is thus a case of **uniformly accelerated motion**.
- Centripetal acceleration is also called radial acceleration as it acts along radius of circle.
- Momentum of the particle changes continuously along with the velocity.
- The centripetal force does not increase the kinetic energy and angular momentum of the particle moving in a circular path.

Non-uniform horizontal circular motion

- If the magnitude of the velocity of the particle in horizontal circular motion changes with respect to time, the motion is known as non-uniform circular motion.
- The acceleration of particle is called tangential acceleration. It acts along the tangent to the circle at a point. It changes the magnitude of linear velocity of the particle.
- Tangential acceleration \vec{f}_T and angular acceleration $\vec{\alpha}$ are related as $\vec{f}_T = \vec{r} \times \vec{\alpha}$ where \vec{r} denotes radius vector.
- Centripetal acceleration f_C and tangential acceleration f_T act at right angles to each other.

$$\therefore f^2 = f_C^2 + f_T^2 = \left(\frac{v^2}{r}\right)^2 + f_T^2.$$

$$\tan \phi = \frac{f_T}{f_C} = \frac{r\alpha}{v^2/r} = \frac{r^2\alpha}{v^2}.$$

PROJECTILE MOTION

- Anything thrown in space and then allowed to move under the effect of gravity alone is called **projectile**.

- The trajectory of the projectile is a parabola if the particle is projected at an angle θ with the horizontal. θ is between 0 and 90° i.e. $0^\circ < \theta < 90^\circ$.
- The initial velocity u of the projectile can be resolved into two components. (i) $u\cos\theta$ along horizontal direction (ii) $u\sin\theta$ along vertical direction.
- There is no acceleration in the horizontal direction, thus horizontal component of velocity remains the same throughout the motion.
- The vertical component of velocity at the highest point of the path is zero. Only the horizontal component $u\cos\theta$ remains at the highest point of path.
- Horizontal range is same whether the particle is projected at an angle θ or $(90^\circ - \theta)$, i.e. the range is same for 30° as well as 60° projection angle but the maximum height more for bigger angles.

- **Equation of path** is $y = x \tan \theta - \frac{gx^2}{2u^2 \cos^2 \theta}$

- **Time of flight** is defined as the total time for which the projectile remains in air.

$$T = \frac{2u \sin \theta}{g}$$

- **Maximum height** is defined as the maximum vertical distance covered by projectile.

$$H = \frac{u^2 \sin^2 \theta}{2g}$$

- **Horizontal range** is defined as the maximum distance covered in horizontal distance.

$$R = \frac{u^2 \sin 2\theta}{g}$$

- If the particle is projected from the top of the tower of height h in horizontal direction, then the height of tower, range and time of flight are related as

$$h = \frac{1}{2}gt^2 \Rightarrow R = ut$$

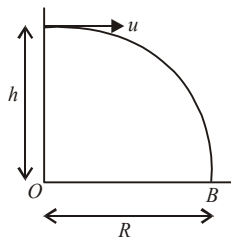

- **Projectile thrown on an inclined plane**

When a projectile is thrown with a velocity u , making an angle θ with the horizontal direction, up the inclined plane while the inclination of the plane with the horizontal direction is θ_0 , then

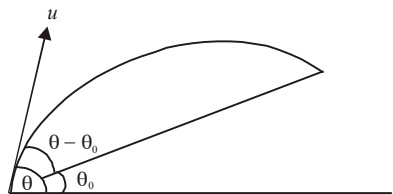

(i) Range of projectile along the inclined plane = R ,

$$R = \frac{u^2}{g \cos^2 \theta} [\sin(2\theta - \theta_0) - \sin\theta_0].$$

(ii) Time of flight on the inclined plane = T .

$$T = \frac{2u \sin(\theta - \theta_0)}{g}$$

(iii) Maximum range on inclined plane = R_{\max} ,

$$R_{\max} = \frac{u^2}{g(1 + \sin\theta_0)}$$

(iv) The angle at which the horizontal range on the inclined plane becomes maximum

$$= \theta, \quad \theta = \frac{\pi}{4} + \frac{\theta_0}{2}.$$

$$(v) \quad T_{\max} = \frac{2u}{g} \sin\left(\frac{\pi}{4} - \frac{\theta_0}{2}\right)$$

Some salient points about angular projection of projectiles

- Horizontal range of projectile is maximum ($= u^2/g$) for a given velocity u if its angle of projection is 45° .
- **Horizontal range** (R) will be same if angle of projection is (a) θ or $(90^\circ - \theta)$
(b) $(45^\circ + \theta)$ or $(45^\circ - \theta)$.
- **Velocity** of projectile is minimum at the highest point of projection ($= u \cos\theta$) and is maximum at the point of projection ($= u$) or at the point of striking the ground ($= u$).
- **Linear momentum** at highest point = $mu \cos\theta$.
- Linear momentum at lowest point = mu .
- **Kinetic energy** at highest point = $\frac{1}{2}m(u \cos\theta)^2$.
- Kinetic energy at lowest point = $\frac{1}{2}mu^2$.
- **Acceleration** of projectile is constant throughout the motion and it acts vertically downwards being equal to g .
- **Angular momentum** of projectile = $(mu \cos\theta) \times h$, where h denotes the height.
- In case of angular projection, the angle between velocity and acceleration varies from $0^\circ < \theta < 180^\circ$,
- The maximum height occurs when the projectile covers a horizontal distance equal to half of the horizontal range, *i.e.* $R/2$.
- When the maximum range of projectile is R , then its maximum height is $R/4$.
- Velocity and acceleration are at right angles to each other at the highest point of journey.

End

laws of motion

- **Newton's first law** : Every body continues in its state of rest or of uniform motion in a straight line unless compelled by some external force to change that state.
- Newton's first law is called **law of Inertia**. The principle of inertia and the foundation of the first law were laid down by **Galileo**. Inertia is that property of body owing to which the body opposes any change in its state of motion.
- **Inertia of rest** is the inability of body to change its state of rest by itself, while inertia of motion is the inability of the body to change its state of motion by itself.
- **Inertia of direction** is the inability of the body to change its direction of motion by itself.
- **Newton's first law** of motion gives the definition of force and the concept of inertia.
- Physical independence of force is a consequence of first law of motion.
- The quantity of motion possessed by a body is called **momentum**. It is measured by the product of mass and velocity.
- **Newton's second law** says that the rate of change of momentum is directly proportional to the applied force.
- An accelerated motion is the result of application of the force.
- **Acceleration** produced in the body depends only on its mass and not on the final or initial velocity.
- Newton's second law of motion gives the idea about the measurement of force.
- Force is an external effort in the form of push or pull which (i) one produces or tries to produce motion in a body at rest, or (ii) stops or tries to stop a moving body, or (iii) changes or tries to change the direction of motion of the body.
- For simplicity, all forces between objects can be placed into two broad categories - (a) **contact forces** and (b) forces resulting from **action at a distance**.
- Frictional force, tensional force, normal force, air resistance force, applied force and spring force are **contact forces**.
- Gravitational force, electrical force, weak force are **action-at-a distance forces**.
- The relative strengths of the gravitational force, the weak force, the electromagnetic force and the strong nuclear force are

$$F_g : F_w : F_e : F_s :: 1 : 10^{25} : 10^{36} : 10^{38}$$
- The **gravitational force** is the force of attraction between two masses. It can be extended upto infinity. It is a central force and conservative in nature. It is the weakest force.

- The force between two static charges is called electrostatic force.
- The force between two magnetic poles is called **magnetic force**.
- If $\vec{F}_1, \vec{F}_2, \vec{F}_3$ are the concurrent forces acting on the same point, then the point will be in equilibrium if $\vec{F}_1 + \vec{F}_2 + \vec{F}_3 + \dots = 0$.
- When many forces act on a body simultaneously at its different points but all in same plane, then they are called **coplanar forces**.
- **Impulse** is the measure of the degree to which an external force produces a change in momentum of the body. The product of a large force acting on a body for a small interval is called impulse.
- **Newton's third** law of motion says that every action has equal and opposite reaction. Action and reaction act on different bodies and they are simultaneous.
- Action and reaction never cancel each other.
- The speed of driving a car safely in darkness depends upon range of the headlight.
- Newton's first and third laws can be derived from the second law therefore second law is the most fundamental law out of the three laws.
- The **law of conservation of linear momentum** is a logical consequence of Newton's second law.
- If n bullets each of mass m and velocity v are fired from a gun then the average force acting on the gun is mnv .
- Principle of conservation of momentum follows from Newton's first law of motion.
- Newton's third law contains law of conservation of momentum.
- Swimming becomes possible because of third law of motion.
- In case of a uniform circular motion, the change in momentum with time is not zero, *i.e.* $\frac{\Delta \vec{p}}{\Delta t} \neq 0$ but $\Delta p = 0$.
- Those frames which are at rest with respect to one another or which are moving with uniform speed with respect to one another are called **inertial reference frames**.
- Newton's laws of motion are valid only in inertial frame of reference.
- A reference frame attached to the earth is an inertial frame by definition.
- When the lift is at rest or in uniform motion, then the weight recorded by the spring balance is equal to the actual weight of the body.
- When the lift is accelerated up, then the weight recorded by the spring balance is more than the actual weight of the body.
- When the lift is accelerated down, the weight recorded by the spring balance is less than the actual weight of the body.
- For a lift falling freely, acceleration of the lift is g and hence the body will feel weightlessness.
- The spring balance will record an increase in weight for a moment, when the lift starts to move up with uniform velocity and then will record the actual weight of the body.

- When the lift just begins to move down with uniform speed, the spring balance will record a decrease in weight for a moment and then will record the actual weight of the body.
- If the downward acceleration of the lift is greater than g , then W is negative. This means that the body will be accelerated upto the ceiling of the lift.
- If no external force acts on a system of two or more bodies, then the total momentum of the system remains constant. This is known as the **principle of conservation of momentum**.
- The motion of a rocket is based on principle of conservation of momentum.
- **Thrust** on the rocket at any instant is equal to the product of the exhaust speed of the burnt gases and the rate of combustion of fuel at that instant.

$$\text{i.e. } F = -u \left(\frac{dM}{dt} \right)$$

–ve sign indicates that thrust on the rocket is in a direction opposite to the direction of escaping gas.

- Velocity of rocket at any instant t , when mass of the rocket is M , is given by

$$v = v_0 + u \log_e \left(\frac{M_0}{M} \right),$$

where v_0 is the initial velocity of the rocket.

If the initial velocity of rocket is zero, then

$$v = u \log_e \left(\frac{M_0}{M} \right)$$

If effect of gravity is also taken into account, then

$$v = u \log_e \left(\frac{M_0}{M} \right) - gt.$$

Friction

- Force of friction opposes relative motion of the point of contact with respect to the surface.
- Force of friction acts parallel to the surface.
- The number of frictional forces acting on a body depends upon the number of contact surfaces. For every contact surface, there is a frictional force.
- Frictional forces are produced on account of intermolecular interactions between the two bodies or surfaces.
- Frictional force is a self adjusting force which increases with increasing applied force till the body is at rest but on the point of motion.
- For frictional force relative motion between two bodies or surfaces is not necessary. In fact, contact between two bodies or surfaces is necessary.

Types of frictional forces

- **Static friction** : It is a self-adjusting force with an upper limit called the limiting friction.
- Dynamic friction/kinetic friction

- Sliding friction
- Rolling friction
- Rolling friction < dynamic friction < sliding friction
- If μ_s = static coefficient of friction, $R = N$ = normal reaction, then static frictional force < $\mu_s R$ (body is at rest). Limiting friction = $\mu_s R$ (body is on point of motion).
- If μ_k = kinetic coefficient of friction, then kinetic frictional force = $\mu_k R$ (body is in motion).
- The limiting frictional force between two surfaces in contact with each other depends only on μ (nature of surfaces) and normal contact force R . It does not depend on their shape, size or surface area.
- Value of μ is always less than one.
- $\mu_s = \tan \lambda$ where λ denotes angle of friction.
- The value of angle of friction for perfectly smooth surface is zero.
- Angle of friction = angle of repose (which is the angle of plane such that a body lying on it is on point of sliding down the plane).

Tension

- Tension force always pulls a body.
- Tension can never push a body or rope.
- Tension across a massless pulley or frictionless pulley remains constant.
- Rope becomes slack when tension force becomes zero.
- When a rope is pulled by a force, the rope becomes tight or taut. This conveys the concept of tension.
- Tension is a reactive force. It is not an active force. A tension cannot be applied externally.

Contact force - Motion of bodies in contact

(a) Two bodies in contact

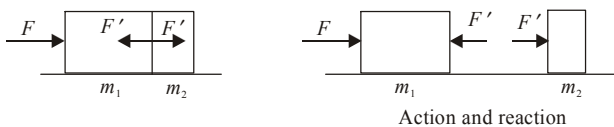

A force F is applied on mass m_1 horizontally. Masses m_1 and m_2 are in contact. Contact force between m_1 and $m_2 = F'$. Contact force is that force with which one body presses the other at the point of contact when the two bodies are placed on a frictionless surface.

$$\therefore \text{Acceleration } a = \frac{\text{Force applied to system}}{\text{mass of system}}$$

$$\therefore a = \frac{F}{(m_1 + m_2)}$$

$$\therefore \text{Contact force on } m_1 = m_1 a = \frac{m_1 F}{(m_1 + m_2)}$$

$$\text{Contact force on } m_2 = m_2 a = \frac{m_2 F}{(m_1 + m_2)}$$

or $F' = m_2 a = \frac{m_2 F}{(m_1 + m_2)}$.

(b) **Three bodies in contact**

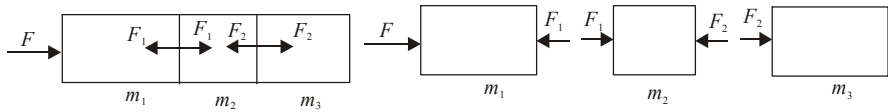

Force applied on the system = F
 Mass of the system = $m_1 + m_2 + m_3$
 Acceleration of the system = a .

\therefore Acceleration of each mass (a) = $\frac{F}{(m_1 + m_2 + m_3)}$

Contact force between m_1 and $m_2 = F_1$
 Contact force between m_2 and $m_3 = F_2$
 For first body, $F - F_1 = m_1 a$
 For second body, $F_1 - F_2 = m_2 a$
 For third body, $F_2 = m_3 a$

$\therefore F_1 = F - m_1 a = F - \frac{m_1 F}{(m_1 + m_2 + m_3)} = \frac{(m_2 + m_3) F}{(m_1 + m_2 + m_3)}$

$\therefore F_2 = m_3 a = \frac{m_3 F}{(m_1 + m_2 + m_3)}$.

(c) **Motion of bodies connected by strings**

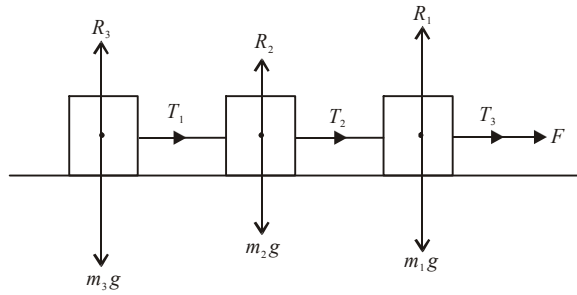

Acceleration in system = a

$\therefore a = \frac{F}{(m_1 + m_2 + m_3)}$

Tension $T_1 = m_3 a = \frac{m_3 F}{(m_1 + m_2 + m_3)}$

Tension $T_2 = (m_2 + m_3) a = \frac{(m_2 + m_3) F}{(m_1 + m_2 + m_3)}$.

Tension $T_3 = F$.

Pulley

- Consider two masses m_1 and m_2 connected at the two ends of a massless inextensible string passing over a frictionless pulley of mass M .

Let the mass of pulley = M

Radius of pulley = R

Equations of motion are :

$$m_1g - T_1 = m_1a \quad \dots \text{(i)}$$

$$T_2 - m_2g = m_2a \quad \dots \text{(ii)}$$

Consider torque on pulley

$$\tau = (T_1 - T_2)R$$

$$\therefore I\alpha = (T_1 - T_2)R$$

$$\text{or } \left(\frac{MR^2}{2}\right)\left(\frac{a}{R}\right) = (T_1 - T_2)R$$

$$\text{or } T_1 - T_2 = \frac{Ma}{2} \quad \dots \text{(iii)}$$

From (i), (ii) and (iii) we get

$$a = \frac{(m_1 - m_2)g}{m_1 + m_2 + \frac{M}{2}}; \quad T_1 = \frac{m_1\left(2m_2 + \frac{M}{2}\right)g}{m_1 + m_2 + \frac{M}{2}}; \quad T_2 = \frac{m_2\left(2m_1 + \frac{M}{2}\right)g}{m_1 + m_2 + \frac{M}{2}}$$

Reaction at pulley $R = T_1 + T_2$

$$R = \frac{\left[4m_1m_2 + \frac{M}{2}(m_1 + m_2)\right]g}{\left(m_1 + m_2 + \frac{M}{2}\right)}$$

- If the mass of the pulley is zero, put $M = 0$.

- If the two masses are equal, put $m_1 = m_2 = m$.

- Consider a body of mass m_2 which rests on a surface which is horizontal. Let a string passing over a pulley connect m_2 with mass m_1 as shown in figure.

(a) Without friction between m_2 and horizontal table,

$$\text{Acceleration, } a = \frac{m_1g}{(m_1 + m_2)}.$$

$$\text{Tension, } T = \frac{m_1m_2g}{(m_1 + m_2)}.$$

(b) With friction between body m_2 and table,

$$\text{Acceleration, } a = \frac{(m_1 - \mu m_2)g}{(m_1 + m_2)}$$

$$\text{Tension, } T = \frac{m_1m_2(1 + \mu)g}{(m_1 + m_2)}.$$

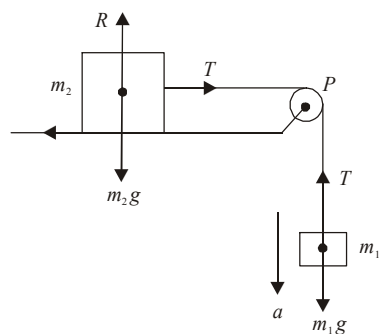
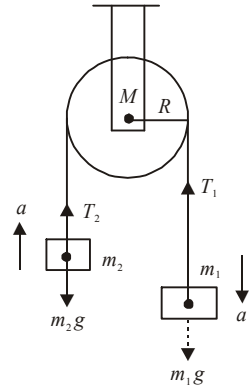

- Two masses are suspended as shown in figure.

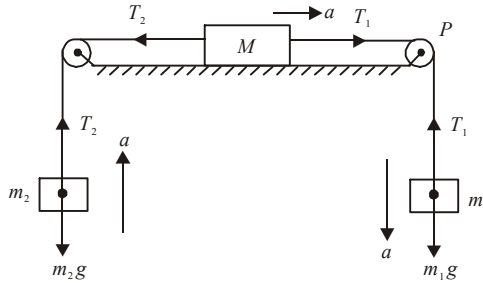

The block on horizontal table moves towards right with acceleration a .

$$\begin{aligned}
 m_1g - T_1 &= m_1a && \dots \text{(i)} \\
 T_2 - m_2g &= m_2a && \dots \text{(ii)} \\
 T_1 - T_2 &= Ma && \dots \text{(iii)}
 \end{aligned}$$

We get, acceleration, $a = \frac{(m_1 - m_2)g}{(m_1 + m_2 + M)}$.

- Two masses are suspended over a pulley on an inclined plane as shown in the figure. The mass m_1 descends with an acceleration a . Mass m_2 is on inclined plane.

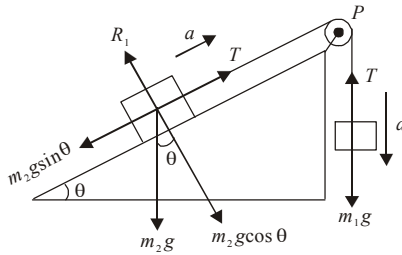

Without friction:

Acceleration, $a = \frac{(m_1 - m_2 \sin \theta)}{(m_1 + m_2)}g$; Tension, $T = \frac{m_1 m_2 (1 + \sin \theta)g}{(m_1 + m_2)}$

With friction:

Acceleration, $a = \frac{[m_1 - m_2(\sin \theta + \mu \cos \theta)]g}{(m_1 + m_2)}$; Tension, $T = \frac{m_1 m_2 (1 - \sin \theta + \mu \cos \theta)g}{(m_1 + m_2)}$

- Masses m_1 and m_2 are connected by a string passing over a pulley such that $m_1 > m_2$.

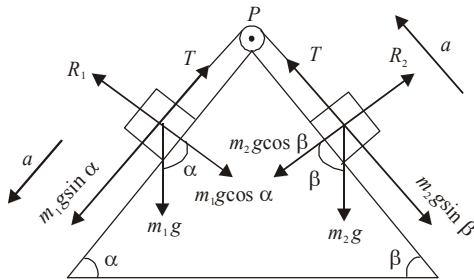

$$\text{Acceleration, } a = \frac{(m_1 \sin \alpha - m_2 \sin \beta)g}{(m_1 + m_2)}; \text{ Tension, } T = \frac{m_1 m_2 (\sin \alpha + \sin \beta)g}{(m_1 + m_2)}$$

- The mass M is connected to m_1 and m_2 via strings over two light pulleys. Let $m_1 > m_2$. Obviously m_1 moves down with acceleration a .

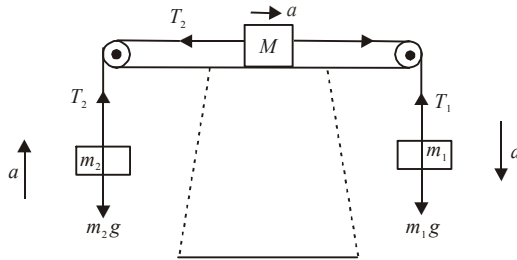

The equations are :

$$m_1 g - T_1 = m_1 a; \quad T_2 - m_2 g = m_2 a; \quad T_1 - T_2 = Ma.$$

By solving these equations, we get

$$\text{Acceleration, } a = \frac{(m_1 - m_2)g}{(m_1 + m_2 + M)}; \text{ Tension, } T_1 = \frac{m_1(2m_2 + M)g}{(m_1 + m_2 + M)}$$

$$\text{Tension, } T_2 = \frac{m_2(2m_2 + M)g}{(m_1 + m_2 + M)}$$

Corollaries

- When the two masses are equal,

$$m_1 = m_2 = m.$$

Acceleration = zero

$$\text{Reaction at pulley} = 2T = 2mg$$

- What happens if a mass m is hanging at one end of string and a student of equal mass m starts climbing up along the string from other end?

By conservation of momentum, the student and the mass will rise up with same speed.

- What happens if one student climbs from one end of string and the other of equal mass but faster speed climbs from other end?

The two will reach the pulley simultaneously.

- Motion on an inclined plane**

The inclined plane may be rough or smooth. A body may move down the plane or up the plane.

- Motion of a body down the rough plane:

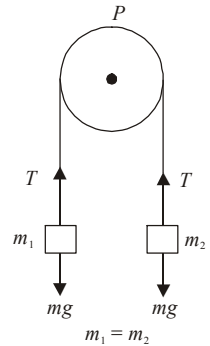
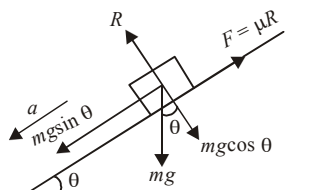

- Normal reaction $R = mg\cos\theta$
 $mg\sin\theta - \mu R = ma$
 $\therefore mg\sin\theta - \mu mg\cos\theta = ma$
 or $a = g(\sin\theta - \mu\cos\theta)$
 \therefore Acceleration down the rough plane $= g(\sin\theta - \mu\cos\theta)$.
 (ii) *Motion of a body down the smooth plane: ($\mu = 0$)*
 \therefore Acceleration of body $= g\sin\theta$.
 (iii) *Motion of a body up the rough plane:*

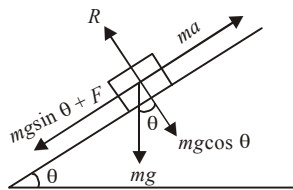

- When the body moves up the plane, the force of friction $F = \mu R$ acts down the plane to oppose the motion.
 $\therefore ma = mgsin\theta + F = mgsin\theta + \mu R$
 $= mgsin\theta + \mu mg\cos\theta = mg(\sin\theta + \mu\cos\theta)$.
 or acceleration $a = g(\sin\theta + \mu\cos\theta)$.
 (iv) *Motion of a body up the smooth plane ($\mu = 0$)*
 Acceleration of body $= g\sin\theta$.
 (v) *Plane is given horizontal acceleration, plane is smooth.*

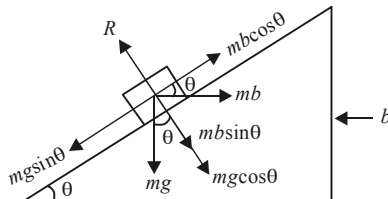

$$mg\cos\theta - mb\cos\theta = ma$$

$$\therefore a = (g\sin\theta - b\cos\theta)$$

If $a = 0$, $b = g\tan\theta$.

End

work, power and energy

WORK

- Whenever a force acting on a body is able to actually move it through some distance in the direction of force, the work is said to be done by the force.
- When a constant force \vec{F} acts on a particle while it moves through a displacement \vec{s} , the force is said to do work W on the particle given by

$$W = \vec{F} \cdot d\vec{s} = Fs \cos \theta$$
 where θ is the smaller angle between \vec{F} and \vec{s} .
- If the force and displacement are in the same direction, $\theta = 0$.
 $\therefore W = Fs$.
- If \vec{F} and \vec{s} are perpendicular to each other, then, $W = \vec{F} \cdot d\vec{s} = Fs \cos 90^\circ = 0$.
 This means that if the displacement of the body is perpendicular to the force no work is done.
- If the force and displacement are variable quantities, then

$$W = \int \vec{F} \cdot d\vec{s}$$
 = area under the force displacement graph, added with proper sign
- Work is a **scalar quantity**.
- In SI system the absolute unit of work is joule, while in CGS system, the unit of work is erg.
- Dimensions of work are
 $W = Fs = [\text{MLT}^{-2}] [\text{L}] = [\text{ML}^2\text{T}^{-2}]$.
- Workdone by a constant force in moving from one point to other depends only on the initial and final positions and not on the actual path followed between two points.
- If the workdone by a force during a round trip of a system is zero, the force is said to be **conservative**, otherwise it is called **non-conservative**. Force of friction is a non-conservative force.
- Workdone in moving an object against gravity depends only on the initial and final positions of the object but not upon the path taken. This shows that **gravitational force is conservative force**.
- All the central forces are conservative forces.

- The workdone by the force of gravity during the motion of a particle through a height h is
 $W = mgh$, where m is the mass of the particle.
- Workdone in compressing/stretching a spring, $W = -\frac{1}{2}kx^2$
where k is spring constant and x is the displacement from normal position of rest.
- When one end of a spring is attached to a fixed vertical support and a block attached to the free end moves on a horizontal table from $x = x_1$ to $x = x_2$, then
$$W = -\frac{1}{2}k(x_2^2 - x_1^2)$$
- Workdone by the couple for an angular displacement of $\Delta\vec{\theta}$, $W = \vec{\tau} \cdot \Delta\vec{\theta}$, where $\vec{\tau}$ is the **torque** of couple.

POWER

- Power is the time rate of doing work. Thus, $\text{Power} = \frac{\text{Work done}}{\text{Time required}}$
- If a constant force F acts on a body for time t and if due to this the body moves a distance s in the direction of the force, with uniform velocity v , then power P developed is given by

$$P = \frac{\vec{F} \cdot \vec{s}}{t} = \vec{F} \cdot \vec{v}. \quad \text{Thus } P = Fv \cos \theta$$

Here θ is the smaller angle between force \vec{F} and velocity \vec{v} of the body.

- Power is a scalar quantity. SI unit of power is watt where 1 watt = 1 joule/sec.
- The practical unit of power is horse power (hp), where 1 hp = 746 watt.
- Dimensions of power are $P = \frac{W}{t} = \frac{[\text{ML}^2\text{T}^{-2}]}{[\text{T}]} = [\text{ML}^2\text{T}^{-3}]$.

ENERGY

- Energy is the capacity of a body for doing work, *i.e.* it is the total amount of work stored up in the body.
- Because the energy of a body represents the total amount of workdone, hence
 - (a) it is a scalar quantity just like work.
 - (b) its dimensions are the same as those of work,
i.e. $[\text{ML}^2\text{T}^{-2}]$.
 - (c) it is measured in the same units as the work, *i.e.* joule and erg.
- Energy can exist in different forms such as mechanical energy, heat energy, sound energy, electrical energy, light energy, etc.
- The mechanical energy is of two types - kinetic energy and potential energy.
- Kinetic energy of a body is the energy acquired by the body by virtue of its motion.

- Kinetic energy is measured by the workdone by the moving body against external impressed force, before coming to rest. If a body of mass m moves with velocity v , its kinetic energy is given by

$$K = \frac{1}{2}mv^2 = \frac{m^2v^2}{2m} = \frac{p^2}{2m}$$

where $p = mv =$ momentum of the body.

- Potential energy of a body is the energy possessed by the body by virtue of its position or configuration. The potential energy is due to the interaction between bodies.
- If a body of mass m be raised through a vertical height h against gravity, then its gravitational potential energy is given as

$$\text{potential energy} = mgh.$$

- Potential energy can be defined only for conservative forces. It does not exist for non-conservative forces. A moving body may or may not have potential energy. Further, potential energy does depends upon the frame of reference.
- Workdone by a force acting on a body is equal to change in kinetic energy of the body. This is called as work energy of the body. This is called as work-energy theorem. Mathematically, work-energy theorem can be written as

$$W = \int_{s_1}^{s_2} \vec{F} \cdot d\vec{s} = \frac{1}{2}mv_1^2 - \frac{1}{2}mv_2^2$$

- For conservative forces the sum of kinetic and potential energies at any point remains constant throughout the motion. It does not depend upon time. This is known as law of conservation of mechanical energy.

Collisions

- **Collision** between two particles is defined as the mutual interaction of the particle for a small interval of time due to which both the energy and momentum of the interacting particles change.
- In physics a collision will take place if either of the two bodies come in physical contact with each other or even when path of one body is affected by the force exerted due to the other.
- **Collisions are of two types:**
 - (a) The collisions, in which both the momentum and kinetic energy of the system remain conserved, are called **elastic collisions**.
 - (b) The collisions in which only the momentum of the system is conserved but kinetic energy is not conserved are called **inelastic collisions**.
- Linear momentum is conserved in both elastic as well as inelastic collision.
- If the initial and final velocities of colliding masses lie along the same line, then it is known as **head-on collision** or one dimensional collision.
- If the velocities of the colliding masses are not collinear, then it is known as **oblique collision** or two dimensional collision.

- In one dimensional elastic collision, the relative velocity of approach ($u_1 - u_2$) before collision is equal to the relative velocity of separation ($v_2 - v_1$) after collision.
- Velocity of the two bodies after collision;

$$v_1 = \frac{(m_1 - m_2)u_1 + 2m_2u_2}{(m_1 + m_2)} \quad \text{and} \quad v_2 = \frac{(m_2 - m_1)u_2 + 2m_1u_1}{(m_1 + m_2)}$$
- If two bodies of equal masses undergo elastic collision in one dimension, then after the collision, the bodies will exchange their velocities.
- Maximum transfer of energy occurs when
 - (a) target body is at rest initially
 - (b) masses of two bodies are equal.

- The loss of kinetic energy in perfectly inelastic collision $\Delta E = \frac{m_1m_2(u_1 - u_2)^2}{2(m_1 + m_2)}$.

- For a perfectly elastic collision,
velocity of separation = velocity of approach
For a perfectly inelastic collision,
velocity of separation = 0.

- In general, the bodies are neither perfectly elastic nor perfectly inelastic. In that case we write:
velocity of separation = e (velocity of approach)
where $0 < e < 1$.

- The constant e depends upon the material of the colliding bodies. This constant is known as coefficient of restitution. If $e = 1$, the collision is perfectly elastic and if $e = 0$, the collision is perfectly inelastic.

- General expression for velocities after direct impact are

$$v_1 = \frac{(m_1 - em_2)u_1 + (1 + e)m_2u_2}{m_1 + m_2}, \quad v_2 = \frac{(1 + e)m_1u_1 + (m_2 - em_1)u_2}{m_1 + m_2}$$

- The loss in kinetic energy of two bodies after an inelastic collision,

$$\Delta E = \frac{m_1m_2}{2(m_1 + m_2)}(u_1 - u_2)^2(1 - e^2)$$

- Suppose, a body is dropped from a height h_0 and it strikes the ground with velocity v_0 . After the inelastic collision let it rise to a height h_1 . If v_1 be the velocity with which the body rebounds, then

$$e = \frac{v_1}{v_0} = \left(\frac{2gh_1}{2gh_0} \right)^{1/2} = \left(\frac{h_1}{h_0} \right)^{1/2}$$

- If after n collisions with the ground, the velocity is v_n and the height to which it rises be h_n , then

$$e^n = \frac{v_n}{v_0} = \left(\frac{h_n}{h_0} \right)^{1/2}$$

- During one dimensional collision, when a particle of mass m_1 moving with velocity u_1 collides with another particle of mass m_2 at rest, three cases of interest arise:
 - (i) If $m_1 = m_2$, then $v_1 = 0$ and $v_2 = u_1$. Under this condition the first particle comes to rest and the second particle moves with the velocity of the first particle before collision. In this case, there occurs **maximum transfer of energy**.
 - (ii) If $m_1 \gg m_2$, then $v_1 = u_1$ and $v_2 = 2u_1$. Under this condition, the velocity of the first particle remains unchanged and the velocity of second particle becomes double that of the first.
 - (iii) If $m_1 \ll m_2$, then $v_1 = -u_1$ and $v_2 = \frac{2m_1}{m_2}u_1$. v_2 is thus approximately zero. Under

this condition, the second particle remains at rest while the first particle moves with the same velocity in the opposite direction.

- When $m_1 = m_2 = m$ but $u_2 \neq 0$, then $v_1 = u_2$ and $v_2 = u_1$. The particles mutually exchange their velocities. Exchange of energy is maximum.
- **Atomic reactor : Slowing down of neutrons**
Hydrogen nuclei and neutrons have almost equal mass. Hence exchange of energy is maximum when they collide. This fact is utilized in atomic reactor for slowing down the fast neutrons.
- **Two dimensional elastic collision or oblique collision**
 - (i) The collision between two particles in which the particles do not move along the same straight line before and after the collision is defined as the two dimensional or oblique collision.
Let $\alpha_1, \alpha_2 =$ angles before collision.
Let $\beta_1, \beta_2 =$ angles after collision

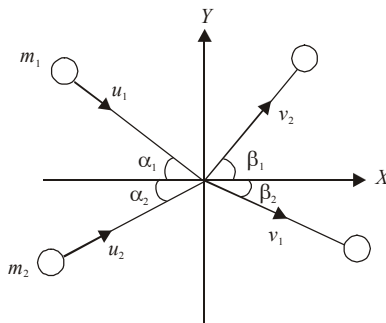

- (ii) If $m_1 = m_2$ and $\alpha_1 + \alpha_2 = 90^\circ$
then $\beta_1 + \beta_2 = 90^\circ$
It means that if two particles of equal mass collide elastically while moving at right angles to each other, then after collision also they move at right angles to each other.
- (iii) If a particle A collides elastically with another particle B of equal mass at rest, at a glancing angle, then after the collision the two particles move at right angles to each other *i.e.* $\alpha + \beta = \pi/2$.

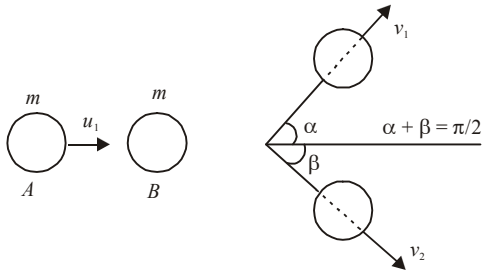

- **In elastic collision,**
 - Linear momentum is conserved
 - Mechanical energy is conserved.
 - For this collision, $e = 1$.
 - The particles do not stick after collision.
 - The particles have different velocities after collision.
- **In perfectly inelastic collision**
 - Linear momentum is conserved
 - Mechanical energy is not conserved. Infact, the maximum energy loss occurs.
 - For this collision, $e = 0$.
 - The particles stick together after collision.
 - The particles, after sticking, move with the same velocity after collision.

End

rotational motion

- For rigid bodies centre of mass is independent of the state of the body *i.e.* whether it is in rest or in accelerated motion centre of mass will remain same.
- Let there be n particles of masses m_1, m_2, \dots, m_n having position vectors $\vec{r}_1, \vec{r}_2, \dots, \vec{r}_n$ respectively.

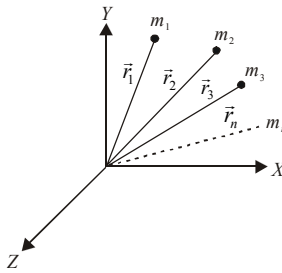

Then the **centre of mass** is given by

$$\vec{r}_{cm} = \frac{m_1\vec{r}_1 + m_2\vec{r}_2 + \dots + m_n\vec{r}_n}{m_1 + m_2 + \dots + m_n} = \frac{\sum_{i=1}^n m_i r_i}{\sum m_i}, \quad X_{cm} = \frac{m_1x_1 + m_2x_2 + \dots + m_nx_n}{m_1 + m_2 + \dots + m_n} = \frac{\sum_{i=1}^n m_i x_i}{\sum m_i}$$

Similarly we can write the expression for Y_{cm} and Z_{cm} .

- **Centre of mass of two particle system :**

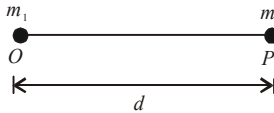

Choosing O as origin of the coordinate axis.

$$\text{Then position of centre of mass from } m_1 = \frac{m_2 d}{m_1 + m_2}.$$

$$\text{Position of centre of mass from } m_2 = \frac{m_1 d}{m_1 + m_2}$$

- **Motion of the centre of mass :** Let m_1 and m_2 be moving with velocities v_1 and v_2 respectively. Then

$$\vec{v}_{cm} = \frac{m_1\vec{v}_1 + m_2\vec{v}_2}{m_1 + m_2}.$$

Similarly,
$$\vec{a}_{cm} = \frac{m_1\vec{a}_1 + m_2\vec{a}_2}{m_1 + m_2}$$

If no external force is acting, whatever may be the internal changes in the system, (a) the centre of mass remains at rest if it had been at rest before internal changes took place, (b) it continues to move with a constant velocity in a straight line if it had uniform motion before internal changes and (c) if an external force is acting on the body before internal changes took place, it will continue and move in the same trajectory and with the same variation in velocity after the change takes place also.

- The position of centre of mass of a body depends on the shape, size and distribution of mass of a body. The centre of mass does not lie necessarily at the centre of the body. Many objects have a point, a line or a plane of symmetry. The centre of mass of such an object then lies at that point, on that line or in that plane.
- The centre of mass of an object need not lie within the object. For a horse shoe or an iron ring, for example, there is no iron at the centre of mass.
- In symmetrical bodies in which the distribution of mass is homogeneous, the centre of mass coincides with the centre of symmetry or geometrical centre.
- The centre of mass changes its position in the translatory motion but remains unchanged in rotatory motion.
- A **rigid body** is any system of particles in which the particles remain fixed in position with respect to one another.
- No real body is perfectly rigid. However, in solid bodies the relative displacement by the external force is so small that it can be neglected.
- The property of a body by virtue of which it opposes any change in its state of rotation about an axis is known as **moment of inertia**.
- The moment of inertia of a rigid body about a given axis is the sum of the products of the masses of its constituent particles and the square of their respective distances from the axis of rotation.

$$I = \sum_{i=1}^n m_i r_i^2$$

- Unit of moment of inertia is kgm^2 . Its dimensional formula is $[\text{ML}^2\text{T}^0]$.
- Moment of inertia of a body about an axis not only depends upon the mass of the body but also upon the distribution of its mass about the axis of rotation.

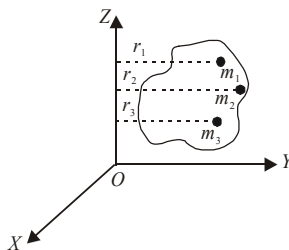

- Greater is the part of the mass of the body away from the axis of rotation, greater is the moment of inertia of the body about that axis.

- The **radius of gyration** of a body about an axis of rotation may also be defined as the root mean square distance of the particles from the axis of rotation and its square when multiplied with the mass of the body gives moment of inertia of the body about the axis.

$$K = \sqrt{\frac{r_1^2 + r_2^2 + \dots + r_n^2}{n}}$$

= root mean square distance of a particles from axis OZ .

- Moments of inertia of homogeneous rigid bodies with different geometries.

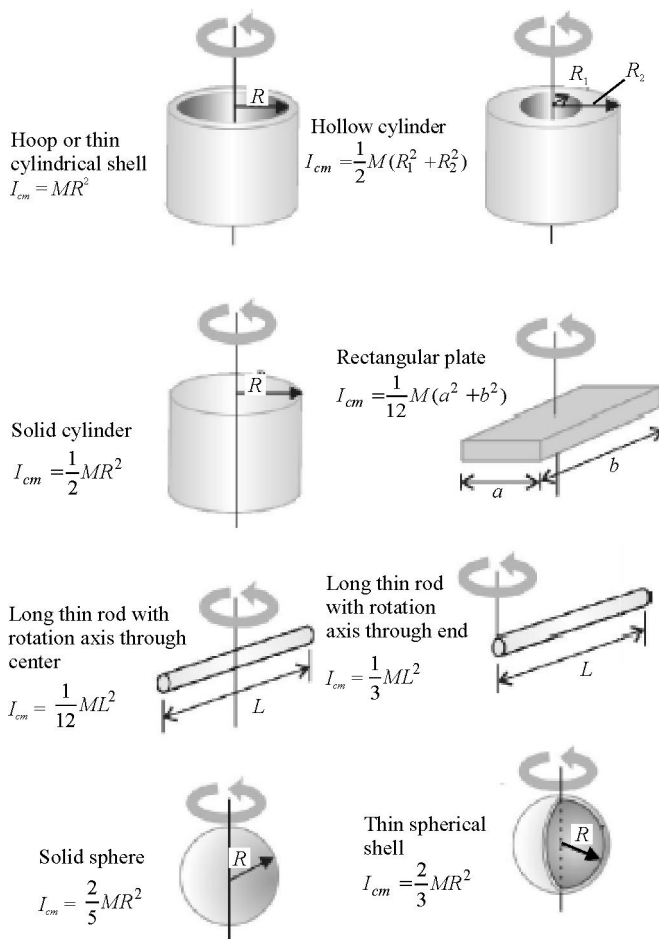

- **Parallel-axis theorem :** The moment of inertia of any body about an arbitrary axis equals the moment of inertia about a parallel axis through the centre of mass plus the total mass times the squared distance between the two axes.
- Mathematically, $I = I_{cm} + Mh^2$.

where I is the moment of inertia about the arbitrary axis, I_{cm} is the moment of inertia about the parallel axis through the centre of mass, M is the total mass of the object and h is the perpendicular distance between the axes. The two axes must be parallel.

- **Perpendicular axes theorem :** The moment of inertia of a plane lamina about an axis perpendicular to the plane of the lamina is equal to the sum of moments of inertia of the lamina about any two mutually perpendicular axes in its own plane and intersecting each other at points where the perpendicular axis passes through it.
- Mathematically, $I = I_x + I_y$
where I_x and I_y are the moments of inertia of plane lamina about the perpendicular axes x and y respectively which lie in the plane of lamina and intersect each other.
- **Torque of a force about the axis of rotation :** Let a force \vec{F} is acting at a distance r from O , the torque $\vec{\tau}$ is given by $\vec{\tau} = \vec{r} \times \vec{F}$.

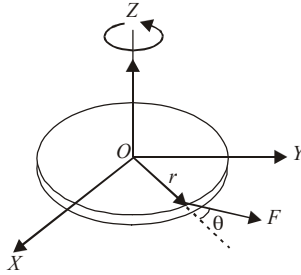

- $\vec{\tau} = I\vec{\alpha}$ has same physical role and importance in rotational motion as $\vec{F} = m\vec{a}$ has in translational motion.
 $\vec{\tau}_{ext} = \frac{d\vec{L}}{dt} = I\vec{\alpha}$,
 \vec{L} = total angular momentum = $I\vec{\omega}$.
- Torque should not be confused with force. Torque depends on force, but it also depends on where the force is applied.
- The torque due to a force is maximum when r is maximum or $\theta = 90^\circ$.
- Unit of torque is Newton-metre (the same as that of work) and the dimensional formula is $[ML^2T^{-2}]$.
- **Conservation of angular momentum :** If $\vec{\tau}_{ext} = 0$, then $d\vec{L}/dt = 0$, therefore \vec{L} is constant.
i.e. in absence of external torque angular momentum remains conserved.
i.e. $I_1\omega_1 = I_2\omega_2$.
- Let a particle of mass m is moving with velocity v . The angular momentum of it about O is $\vec{L} = \vec{r} \times m\vec{v}$.

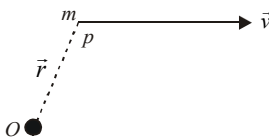

\Rightarrow magnitude of angular momentum = magnitude of linear momentum \times perpendicular distance of momentum vector from the point about which angular momentum is to be calculated.

- **Angular impulse :** The angular impulse of a torque in a given time interval is defined as

$$\vec{J} = \int_{t_1}^{t_2} \vec{\tau} dt$$

\vec{J} is also equal to change in angular momentum.

$$\vec{J} = I_1 \vec{\omega}_1 - I_2 \vec{\omega}_2$$

- **Motion of a body rolling down, without slipping, along an inclined plane**

Let length of slope = S

Height of slope = h

Inclination of slope = θ

Radius of gyration = K

Radius of rolling body = R

Velocity on reaching $A = v$

Acceleration on reaching $A = a$

Time on reaching $A = t$

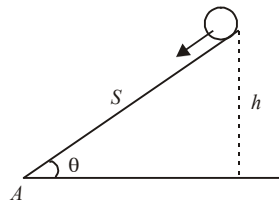

$$\therefore v = \sqrt{\frac{2gh}{1 + \frac{K^2}{R^2}}} = \sqrt{\frac{2gS \sin \theta}{1 + \frac{K^2}{R^2}}}, \quad a = \frac{g \sin \theta}{1 + \frac{K^2}{R^2}}, \quad t = \sqrt{\frac{2S \left(1 + \frac{K^2}{R^2}\right)}{g \sin \theta}}$$

- For circular ring, $I = MR^2$

- For circular disc or solid cylinder, $I = \frac{MR^2}{2}$

- For solid sphere, $I = \frac{2}{5}MR^2$

- For spherical shell, $I = \frac{2}{3}MR^2$

- For cylindrical shell, $I = MR^2$.

Thus if a solid sphere, a circular disc, a solid cylinder, a circular ring and a cylindrical shell are released simultaneously along an inclined slope, the sphere will reach the bottom first, the ring along with the cylindrical shell will reach the bottom last.

- **Total kinetic energy of a rolling body**

Total kinetic energy = kinetic energy of translation + kinetic energy of rotation

$$\text{K.E.} = \frac{1}{2}mv^2 + \frac{1}{2}I\omega^2.$$

- **Power delivered and workdone by torque**

Power = $P = \tau \cdot \omega$

$$\text{Workdone} = W = \int_{\theta_1}^{\theta_2} \tau d\theta$$

- It τ is constant, then $W = \tau (\theta_2 - \theta_1)$ or $W = \tau \times \text{angle moved by the particle.}$
- Sliding motion has only translational motion. Its kinetic energy is $K.E. = \frac{1}{2}mv^2$.
- In case of a rolling body, all points of a rigid body have same angular speed but different linear speeds.

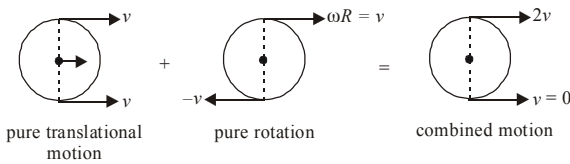

Translatory motion	Rotatory motion
1. All the constituent particles of the rigid body parallel to one another in straight lines.	1. The particles move parallel to one another in circles of different radii about the given axis of rotation.
2. All the particles have same linear velocity.	2. All the particles have same angular velocity. As $v = r\omega$, the particles at different r have different linear velocities.
3. All the particles undergo same linear displacement.	3. All the particles undergo same angular displacement.
4. All the particles have same linear acceleration.	4. All the particles have same angular acceleration.
5. The position of the centre of mass changes with time.	5. The distance of centre of mass from the axis of rotation remains constant with respect to time.
6. Mass is analogous to moment of inertia. Mass depends on the quantity of matter in the body.	6. Moment of inertia (I) is analogous to mass. Moment of inertia (I) depends on distribution of mass about axis of rotation.
7. Kinetic energy of translation = $\frac{1}{2}mv^2$	7. Kinetic energy of rotation = $\frac{1}{2}I\omega^2$
8. Force produces the translatory motion.	8. Torque produces the rotational motion.
9. Work done = W $W = \text{force} \times \text{displacement}$	9. $W = \text{torque} \times \theta$
10. Force = mass \times acceleration	10. Torque = $I \times$ angular acceleration
11. Linear momentum = p $p = \text{mass} \times \text{linear velocity}$	11. Angular momentum = $I\omega$ where $\omega =$ angular velocity
12. Impulse = force \times time	12. Angular impulse = torque \times time
13. Power = force \times velocity	13. Power = torque $\times \omega$

gravitation

- Gravitational force is attractive force between two masses M_1 and M_2 separated by a distance r . It is given by $F = -G (M_1 M_2 / r^2)$, where G is universal gravitational constant, $G = 6.67 \times 10^{-11} \text{ Nm}^2 \text{ kg}^{-2}$. The negative sign shows that force is attractive.
- Dimensional formula of G is $[\text{M}^{-1} \text{L}^3 \text{T}^{-2}]$.
- The gravitation is the central force. It acts along the line joining the particles. It is a conservative force. The work- done by it is independent of the path followed. This force is attractive in nature.
- It is the weakest force in nature. It is 10^{38} times smaller than nuclear force and 10^{36} times smaller than electric force.
- Gravitation is independent of the presence of other bodies around it.
- The gravitational pull of the earth is called gravity.
- The gravitation forces between two bodies are action-reaction pairs. The law of gravitation is called universal as it is applicable to all bodies, irrespective of their size, shape or position. This force does not depend upon the state of the bodies nature of the intervening medium, temperature and other physical condition of the bodies.
- In motion of the planets and satellites, force of gravitation provides the necessary centripetal force due to which earth revolves around the sun and moon around the earth.
- The value of acceleration due to gravity increases as we go from equator to the pole.
- The value of the acceleration due to gravity on the moon is about one sixth of that on the earth and on the sun is about 27 times that on the earth.
- Among the planets, the g is minimum on the mercury.
- Acceleration due to gravity on the surface of the earth is given by, $g = GM/R^2$, where M is the mass of the earth and R is the radius of the earth.
- Acceleration due to gravity at a height h above the surface of the earth is given by

$$g_h = GM/(R + h)^2 \cong g (1 - 2h/R).$$

The approximation is true when $h \ll R$.

- Value of g at depth d from earth's surface

$$(a) \quad g' = g \left[1 - \frac{d}{R} \right]$$

$$(b) \quad g' = \frac{GM}{R^3} (R - d)$$

- The value of g at a height h from the surface and $h \ll R$ is $g' = g \left(1 - \frac{2h}{R}\right)$.
- The value of g at latitude λ is
 - (a) $g' = g - \omega^2 R_e \cos^2 \lambda$
 - (b) At the equator $\lambda = 0$. $\therefore g' = g - \omega^2 R_e$
 - (c) At the poles $\lambda = \pi/2$. $\therefore g' = g$.
- The decrease in g with latitude is caused by the rotation of the earth about its own axis. A part of g is used to provide the centripetal acceleration for rotation about the axis.
- The rotation of the earth about the sun has no effect on the value of g .
- Decrease in g in going from poles to the equator is about 0.35% .
- The weight of the body varies in the same manner as the g does. ($W = mg$).
- The gravitational force of attraction acting on a body of unit mass at any point in the gravitational field is defined as the intensity of gravitational field (E_g) at that point.

$$E_g = \frac{F}{m} = \frac{GM}{r^2}.$$

- The gravitational potential energy of a mass m at a point above the surface of the earth at a height h is given by $\frac{-GMm}{R+h}$. The negative sign implies that as R increases, the gravitational potential energy decreases and becomes zero at infinity.
- The body is moved from the surface of earth to a point at a height h above the surface of earth then change in potential energy will be mgh .
- Gravitational potential at a point above the surface of the earth at a height h is $-GM/(R+h)$. Its unit is joule/kilogram.
- Gravitational mass, M_g is defined by Newton's law of gravitation.

$$M_g = \frac{F_g}{g} = \frac{W}{g} = \frac{\text{Weight of body}}{\text{Acceleration due to gravity}}$$

$$\frac{(M_1)_g}{(M_2)_g} = \frac{F_{g1} g_2}{g_1 F_{g2}}$$

- Let $\omega_0 =$ angular speed of the satellite, $v_0 =$ orbital speed of the satellite, then $v_0 = (R+h)\omega_0$, where $R =$ radius of the earth and $h =$ height of the satellite above the surface of the earth. Let $g =$ acceleration due to gravity on the surface of the earth, $T =$ time period of the satellite, $M =$ mass of the earth. Then different quantities connected with satellite at height h are as follows:

$$(a) \quad \omega_0 = \left[\frac{GM}{(R+h)^3} \right]^{1/2} = R \left[\frac{g}{(R+h)^3} \right]^{1/2}.$$

(b) $T = \frac{2\pi}{\omega_0}$ and frequency of revolution, $\nu = \frac{\omega_0}{2\pi}$.

(c) $v_0 = \left[\frac{GM}{R+h} \right]^{1/2} = R \left[\frac{g}{R+h} \right]^{1/2}$

Very near the surface of the earth, we get the values by putting $h = 0$. That is:

(i) $\omega_0 = \left[\frac{GM}{R^3} \right]^{1/2} = \left[\frac{g}{R} \right]^{1/2}$

(ii) $v_0 = \left[\frac{GM}{R} \right]^{1/2} = [gR]^{1/2}$

(iii) $T \cong 2\pi \left[\frac{R}{g} \right]^{1/2} = 5078 \text{ sec} = 1 \text{ hour } 24.6 \text{ minute.}$

- Altitude or height of satellite above the earth's surface, $h = \left(\frac{T^2 R^2 g}{4\pi^2} \right)^{1/3} - R$.
- Angular momentum, $L = mv(R+h) = [m^2 GM(R+h)]^{1/2}$.
- Above the surface of the earth, the acceleration due to gravity varies inversely as the square of the distance from the centre of the earth.

$$g' = \frac{gR^2}{(R+h)^2}.$$

- The gravitational potential energy of a satellite of mass m is $U = \frac{-GMm}{r}$, where r is the radius of the orbit. It is negative.
- Kinetic energy of the satellite is $K = \frac{1}{2}mv_0^2 = \frac{GMm}{2r}$.
- Total energy of the satellite $E = U + K = -\frac{GMm}{2r}$
-ve sign indicates that it is the binding energy of the satellite.
- Total energy of a satellite at a height equal to the radius of the earth is given by

$$-\frac{GMm}{2(R+R)} = -\frac{GMm}{4R} = \frac{1}{4}mgR.$$

where $g = GM/R^2$ is the acceleration due to gravity on the surface of the earth.

When the total energy of the satellite becomes zero or greater than zero, the satellite escapes from the gravitational pull of the earth.

- If the radius of planet decreases by $n\%$, keeping the mass unchanged, the acceleration due to gravity on its surface increases by $2n\%$ i.e. $\frac{\Delta g}{g} = -\frac{2\Delta R}{R}$

- If the mass of the planet increases by $m\%$ keeping the radius constant, the acceleration due to gravity on its surface increases by $m\%$ $\left[\frac{\Delta g}{g} = \frac{\Delta M}{M} \right]$ where $R = \text{constant}$.
- If the density of planet decreases by $p\%$ keeping the radius constant, the acceleration due to gravity decreases by $p\%$.
- If the radius of the planet decreases by $q\%$ keeping the density constant, the acceleration due to gravity decreases by $q\%$.
- For the planets orbiting around the sun, the angular speed, the linear speed and kinetic energy change with time but the angular momentum remains constant.
- The minimum velocity with which a body must be projected in the atmosphere so as to enable it to just overcome the gravitational attraction of the earth is called escape velocity. *i.e.* $v_e = \sqrt{2gR}$, where $R = \text{radius of earth}$.
- The relation between orbital velocity of satellite and escape velocity is $v_e = \sqrt{2} v_o$. *i.e.* if the orbital velocity of a satellite revolving close to the earth happens to increase to $\sqrt{2}$ times, the satellite would escape.
- There is no atmosphere on the moon because the escape velocity on the moon is low.
- If the orbital radius of the earth around the sun be one fourth of the present value, then the duration of the year will be one eighth of the present value.
- Weightlessness is a situation in which the effective weight of the body becomes zero. Circumstances when this condition arises.
 - (i) When the body is taken at the centre of the earth.
 - (ii) When a body is lying in a freely falling lift, ($a = g$).
 - (iii) When the body is inside a space craft or satellite which is orbiting around the earth.
- **Kepler's first law (law of orbit)** - Every planet revolves around the sun in an elliptical orbit. The sun is situated at one focus of the ellipse.
- **Kepler's second law (law of area)** - The radius vector drawn from the sun to a planet sweeps out equal areas in equal intervals of time. *i.e.* the areal velocity of planet around the sun is constant.
- **Kepler's third law (law of period)** - The square of the time period of revolution of a planet around the sun is directly proportional to the cube of semi-major axis of its elliptical orbit, *i.e.* $T^2 \propto a^3$,
where $a = \text{semi-major axis of the elliptical orbit of the planet around the sun}$.
- **Shape of orbit of a satellite** - The shape of orbit of a satellite depends upon its velocity of projection v from earth.
 - (a) If $v < v_o$, the satellite falls back to earth following a spiral path.
 - (b) If $v = v_o$, the satellite revolves in circular path/orbit around earth.
 - (c) If $v > v_o$, but less than escape velocity v_e , *i.e.* $v_o < v < v_e$, the satellite shall revolve around earth in elliptical orbit.

- (d) If $v = v_e$, the satellite will escape away following a parabolic path.
- (e) If $v > v_e$, the satellite will escape away following a hyperbolic path.
- **Geo-stationary satellite/Parking orbit**
 - (a) Time period = 24 hour
It is isochronous with earth.
 - (b) The angular velocity of satellite must be in the same direction as that of the earth. It thus revolves around earth from west to east. Its relative angular velocity with respect to earth is zero.
 - (c) The orbit of satellite should be circular.
 - (d) The orbit should be in equatorial plane of earth. It contains centre of earth as well as equator.
 - (e) It should be at 36000 km from the surface of earth. It is thus (36000 + 6400) km or 42400 km from the centre of earth.
Radius of parking orbit = 42400 km.
 - (f) A satellite revolving in stable orbit does not require any energy from an external source. The work done by the satellite in completing its orbit is zero.
 - (g) Acceleration due to gravity is used up in providing centripetal acceleration to the satellite. Hence effective g inside the satellite is zero.
 - (h) Its orbital velocity = 3.1 km/sec
Its angular velocity = $\frac{2\pi}{24}$ radian/hour.
 - **For a satellite orbiting near earth's surface**
 - (a) Time period = 84 minute approximately
 - (b) Orbital velocity = 8 km/sec
 - (c) Angular speed $\omega = \frac{2\pi}{84} \frac{\text{radian}}{\text{min}} = 0.00125 \frac{\text{radian}}{\text{sec}}$.
 - **Inertial mass and gravitational mass**
 - (a) Inertial mass = $\frac{\text{force}}{\text{acceleration}}$
 - (b) Gravitational mass = $\frac{\text{weight of body}}{\text{acceleration due to gravity}}$
 - (c) They are equal to each other in magnitude.
 - (d) Gravitational mass of a body is affected by the presence of other bodies near it. Inertial mass of a body remains unaffected by the presence of other bodies near it.



End

properties of matter

Intermolecular forces

- The force between two molecules is known as intermolecular forces.
- These forces are of electrical origin.
- They are also known as van der Waal forces. These forces are very weak forces.
- The potential energy is minimum and the kinetic energy is maximum when the two molecules are separated by $r = r_0$. This distance is known as normal distance. The molecules are in the state of equilibrium. No net force acts between the molecules.

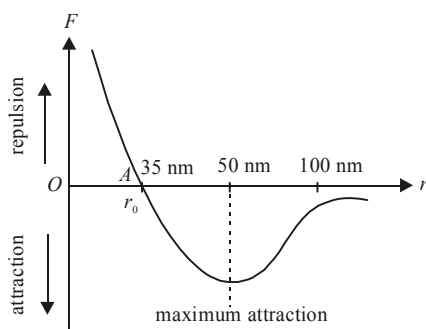

- When $r > r_0$, the force is of attraction and potential energy is negative.
 - When $r < r_0$, the force is of repulsion and potential energy is positive.
 - At point A, the potential energy becomes minimum and the molecules cannot come closer. The distance OA denotes the minimum possible distance between molecules.
 - Force of cohesion and adhesion are intermolecular forces.
 - The potential energy is present in the molecules on account of intermolecular forces.
- $$F = -\frac{dU}{dr}, \text{ where } U = \text{potential energy.}$$
- $F(r) = \frac{A}{r^{13}} - \frac{A}{r^7}$.
 - **Positive and negative potential energy**
 - (i) The value of potential energy U can be zero or positive or negative.
 - (ii) The potential energy due to forces of attraction is negative.
 - (iii) The potential energy due to forces of repulsion is positive.

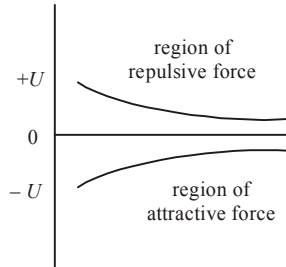

- **States of equilibrium**

(i) For a stable equilibrium, potential energy U is minimum. $\frac{d^2U}{dx^2}$ is positive.

(ii) For unstable equilibrium, potential energy U is maximum. $\frac{d^2U}{dx^2}$ is negative.

(iii) For neutral equilibrium, potential energy U is constant. $\frac{d^2U}{dx^2} = 0$.

- **Four states of matter**

(i) **Solid state** : The intermolecular forces are strongest, the kinetic energy of molecules is less than their potential energy and intermolecular distance remains constant.

(ii) **Liquid state** : The intermolecular forces are less strong than solids and more strong than gases, kinetic energy is more than potential energy and the intermolecular distance does not remain constant.

(iii) **Gas state** : The intermolecular forces are weakest, the kinetic energy of molecules is much larger than their potential energy and intermolecular distance does not remain constant.

(iv) **Plasma state** : It is a state of matter in which the medium is in the form of positive and negative ions.

- **Types of bonding** : There are mainly five types of bonding among the atoms or molecules.

(i) **Ionic bonding** - Cohesive energy is high and electrical conductivity is very low.

e.g. NaCl, LiF. It is strongest bonding.

(ii) **Covalent bonding** - Cohesive energy is high. Semiconductors like Ge, Si, diamond have covalent bondings.

(iii) **Hydrogen bonding** - Cohesive energy is low. Insulators have this bonding.

(iv) **Hydrogen bonding** as DNA and H_2O .

(v) **Metallic bonding** as in metals.

ELASTICITY

- **For elastic constants : Inter relations**

Y = Young's modulus, η = Rigidity modulus

K = Bulk modulus, σ = Poisson's ratio

- (a) $Y = 2\eta(1 + \sigma)$
- (b) $Y = 3K(1 - 2\sigma)$
- (c) $\frac{9}{Y} = \frac{3}{\eta} + \frac{1}{K}$ or $Y = \frac{9K\eta}{\eta + 3K}$.
- (d) $\sigma = \frac{3K - 2\eta}{6K + 2\eta}$

• **Range of σ**

- (a) $\sigma = -1$ to 0.5
- (b) When $\sigma = 0.5$, $K = \infty =$ matter is incompressible. This is not possible in practice.
- (c) When $\sigma = -1$, $\eta = \infty =$ not possible. σ in practice cannot be negative.
- (d) σ has no unit, no dimensions.

• **Adiabatic and isothermal elasticities**

$E_\phi =$ adiabatic elasticity $= \gamma P$ where $\gamma = C_p/C_v$ for gas.

$E_\theta =$ isothermal elasticity $= P$ where P denotes pressure.

$$\frac{E_\phi}{E_\theta} = \frac{\gamma P}{P} = \gamma = \frac{C_p}{C_v}.$$

• **Elastic potential energy**

- (a) Workdone per unit volume $= \frac{1}{2} \times \text{stress} \times \text{strain}$

or Energy density $= \frac{1}{2} \times \text{stress} \times \text{strain}$

- (b) Workdone $= \frac{1}{2} \times \text{stress} \times \text{strain} \times \text{volume}$

- (c) Energy density $= \frac{1}{2} \times \text{stress} \times \text{strain} = \frac{1}{2} \times \frac{\text{stress}}{\text{strain}} \times (\text{strain})^2 = \frac{1}{2} \times Y \times (\text{strain})^2$.

- (d) Workdone per unit volume $= \frac{1}{2} \times \text{stress} \times \frac{\text{stress}}{Y} = \frac{(\text{stress})^2}{2Y}$.

• **Force required to prevent a rod from increasing in length when the rod is heated**

- (a) Force $= YA\alpha(\theta)$ where α denotes coefficient of linear expansion, $\theta =$ change of temperature.

- (b) Thermal stress $= F/A = Y\alpha\theta$.

• **Interatomic force constant (k)**

$$k = \frac{\text{Interatomic force}}{\text{Change in interatomic distance}}$$

$$k = \text{Young's modulus} \times \text{interatomic distance}$$

Cantilever and beam

- A beam, clamped at one end and loaded at free end is known as cantilever.
- Depression at the free end of cantilever $= \delta$.

$$\delta = \frac{Wl^3}{3YI_G}$$

where l denotes length of cantilever, $I_G =$ geometrical moment of inertia of the cross-section of the beam.

- $I_G = \frac{bd^3}{12}$.
For a beam with rectangular cross-section, b = breadth, d = thickness.
- $I_G = \frac{\pi r^4}{4}$.
For a beam with circular cross-section having radius r .
- Depression produced at the centre of beam supported at two ends and loaded at the middle.

$$\delta = \frac{Wl^3}{48YI_G}, \text{ where } l \text{ denotes length of beam.}$$

$$(i) \delta = \frac{Wl^3}{4Ybd^3} \text{ for rectangular cross-section}$$

$$(ii) \delta = \frac{Wl^3}{12\pi r^4 Y} \text{ for circular cross-section}$$

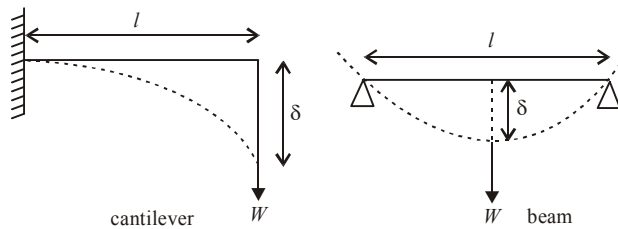

Torsion of a cylinder and workdone in twisting

- Couple per unit twist is $C = \frac{\pi\eta r^4}{2l}$

where l = length of cylinder, r = radius of cylinder
 η = modulus of rigidity of the material of cylinder.

- Workdone in twisting the cylinder through an angle θ

$$= \int_0^\theta C \cdot \theta \cdot d\theta = \frac{1}{2} C\theta^2.$$

- Relation between angle of twist θ and angle of shear ϕ . Arc $BB' = r\theta = l\phi$

$$\therefore \phi = \frac{r}{l} \cdot \theta.$$

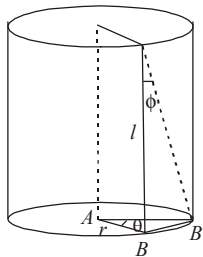

Variation in elasticity

- **Effect of temperature**
 - (i) In general elasticity decreases as the temperature increases.
 - (ii) INVAR is an exception. There is no effect of temperature on elasticity of invar. Invar is infact a short form of invariable.
- **Effect of impurities**
 - (i) If the impurity is more elastic, the elasticity of the material increases.
 - (ii) If the impurity is more plastic (less elastic) the elasticity of material decreases.
- On hammering or rolling elasticity increases.
- On annealing *i.e.* on alternate heating and cooling elasticity decreases.

Some salient points about elasticity

- Units and dimensions of coefficient of elasticity (Y , η and K) stress and pressure are same.

$$\text{Unit} = \frac{\text{newton}}{(\text{metre})^2} = \frac{\text{N}}{\text{m}^2} = \text{Nm}^{-2}.$$

$$\text{Dimensions} = [\text{ML}^{-1}\text{T}^{-2}]$$

- Coefficient of elasticity depends upon the material, its temperature and purity but not on stress or strain.
- For the same material, the three coefficients of elasticity *i.e.* Y , η and K have different magnitudes.
- **Compressibility** : The reciprocal of bulk modulus of elasticity is defined as compressibility.
- Young's modulus Y and rigidity modulus η are possessed by solid materials only.
- Every force produces extension along its own direction and simultaneous compression along perpendicular direction.
- Factor of safety = $\frac{\text{breaking stress}}{\text{normal working stress}} = \frac{\text{breaking stress} \times \text{area}}{\text{force}}$
- **Elastic relaxation time**
 - (i) The time delay in restoring the original form after removal of deforming force is called elastic relaxation time.
 - (ii) For phosphor bronze, silver and gold, the time is negligibly small.
 - (iii) For Quartz, it is minimum.
 - (iv) For glass, it is high.
- For liquids, modulus of rigidity η is zero.

- If real original length of wire = L , then $L = \frac{F_2 L_1 - F_1 L_2}{F_2 - F_1}$

where F_1 and F_2 are the stretching forces and L_1 and L_2 are the respective final lengths of a wire.

$$Y = \frac{F_1 L}{A(L_1 - L)} = \frac{F_2 L}{A(L_2 - L)}$$

$$F_1(L_2 - L) = F_2(L_1 - L)$$

$$\therefore L = \frac{F_2 L_1 - F_1 L_2}{F_2 - F_1}$$

- **Poisson's ratio (σ)**

- (i) If $\sigma = 0.5$, there shall be no change in volume of wire on loading. This is not possible.
- (ii) If σ is -ve, it means that if the length of a wire increases, its radius also increases. This is not possible.
- (iii) $\sigma = 0.46$ for rubber, $\sigma = 0.25$ for steel, $\sigma = 0.20$ for glass.

- **Breaking stress** is fixed for a material. It depends upon the material.

- **Tensile strength** is the breaking stress for a wire of unit cross-section.

- **Quartz** is the best example of a perfectly elastic body and **putty** is the best example of a perfectly plastic body.

- (i) For a perfectly rigid body, strain produced by the applied force is zero.

$$Y = \frac{\text{stress}}{\text{strain}} = \frac{\text{stress}}{0} = \infty.$$

$$Y = \infty = \text{infinity.}$$

- (ii) For a perfectly rigid body, strain produced is zero.

$$K = \frac{\text{stress}}{\text{strain}} = \frac{\text{pressure}}{\text{zero}} = \infty = \text{infinity}$$

- (iii) Shear modulus of elasticity of a liquid is zero because a liquid does not oppose change in its shape.

- Potential energy of a stretched spring $U = \frac{1}{2}kx^2$ where k is spring constant and x denotes the amount of stretch.

$$F = kx$$

$$dW = kx \, dx$$

$$W = \int_0^x kx \, dx = \frac{1}{2}kx^2$$

$$W = \frac{k}{2}(l_2^2 - l_1^2) \text{ when stretched from } l_1 \text{ to } l_2.$$

- **Ductile materials** : The materials which exhibit large plastic range beyond the elastic limit such that they can be drawn into wire springs and sheets are known as ductile materials.

e.g. silver, steel, copper, aluminium.

- **Brittle materials** are those material which show a very small plastic range beyond the elastic limit. The breaking point lies very close to elastic limit e.g. rubber, glass.

HYDROSTATICS

- In fluid mechanics the following properties of fluid would be considered:

- (i) when the fluid is at rest - **hydrostatics**
- (ii) when the fluid is in motion - **hydrodynamics**.

Pressure due to a liquid

- The thrust exerted by a liquid at rest per unit area of the substance in contact with the liquid is called **pressure**. If F is the thrust exerted by a liquid on a surface of small area ΔA , then pressure is given by

$$P = \lim_{\Delta A \rightarrow 0} (F / \Delta A)$$

- The unit of pressure is dyne/cm² in CGS system and N/m² in SI. A pressure of one N/m² is also called pascal.
- Pascal's law** : Pressure applied to enclosed liquid is transmitted equally in all directions, to every position of liquid and wall of container.
- Hydrostatic pressure of liquid column**: Pressure = σgh
where σ = density of liquid, h = height of liquid column.
- Brahma's hydraulic press** is based upon Pascal's law of liquid pressure.
- Unit of pressure** is pascal. Its symbol is Pa.
Bar = 10⁵ Pa, torr = 1 mm of Hg column.

Density and relative density

- Density = mass/volume.
For water, density = 10³ kg/m³.
- One litre = 1000 cc = 1000 cm³ = 1000 × (10⁻² m)³ = 10⁻³ m³.
- Relative density = $\frac{\text{Density of substance}}{\text{Density of water at 4}^\circ\text{C}} = \frac{\text{Weight of substance in air}}{\text{Loss of weight in water}}$
- Density of mixture = $\frac{m_1 + m_2}{V_1 + V_2} = \frac{(m_1 + m_2)\rho_1\rho_2}{(m_1\rho_2 + m_2\rho_1)}$
where m denotes mass and ρ denotes density of liquid.
 - If $m_1 = m_2 = m$, $\rho = \frac{2\rho_1\rho_2}{\rho_1 + \rho_2}$ or $\frac{2}{\rho} = \frac{1}{\rho_1} + \frac{1}{\rho_2}$
∴ Density of mixture of two liquids is harmonic mean of the two densities.
 - If $V_1 = V_2 = V$,
 $\rho = \frac{m_1 + m_2}{V_1 + V_2} = \frac{\rho_1 V + \rho_2 V}{V + V} = \frac{\rho_1 + \rho_2}{2}$
∴ Density of mixture of two liquids is arithmetic mean of two densities.
- Density of liquid varies with pressure.
 $\rho = \rho_0 \left[1 + \frac{\Delta P}{K} \right]$, where ΔP = change in pressure,
 K = bulk modulus of elasticity of liquid.
- Relative density, also known as specific gravity, has no unit, no dimension.

Archimede's principle

- When a solid body is immersed, partly or wholly, in a liquid at rest, it loses a weight which is equal to weight of the liquid displaced by the immersed portion of solid body.

- Observed weight = true weight – weight of liquid displaced
or $T = Mg - mg = \rho gh - \sigma gh = ahg(\rho - \sigma)$
or $T = ahg\rho\left(1 - \frac{\sigma}{\rho}\right) = W\left(1 - \frac{\sigma}{\rho}\right)$.
where ρ = density of solid, σ = density of liquid
 W = true weight of body
- Weight of liquid displaced = upthrust = loss in weight of body.

Laws of floatation

- Weight of floating body = weight of liquid displaced.
- Volume of body immersed = volume of liquid displaced.
- If density of solid body is greater than density of liquid, the body will sink in the liquid.
Here $d_S > d_L$ or $\rho > \sigma$.
Weight of body > weight of liquid displaced.
- If $d_S < d_L$, the solid body floats on the liquid surface. ($\rho < \sigma$).
Here weight of body < weight of liquid displaced.
- If $d_S = d_L$ or $\rho = \sigma$, the body will stay at rest anywhere in the liquid.
- The floating body will be in stable equilibrium when the metacentre lies above centre of gravity of body.
- The floating body will be in unstable equilibrium when the metacentre lies below centre of gravity of body.
- The floating body will be in neutral equilibrium when the meta cente coincides with centre of gravity of body.
- The upward force or upthrust acting on the body immersed in a liquid is known as **Buoyant force** of buoyancy.
- The centre of gravity of displaced liquid is known as **centre of buoyancy**.
- If a person floats on his back on the surface of water, the apparent weight of the person is zero.

Surface tension

- **Surface tension** : The free surface of every liquid has always a tendency to contract to a minimum possible surface area and thus behaves like a stretched membrane having a tension in all directions parallel to the surface. Thus,
Surface tension is the property of liquid by virtue of which its free surface behaves like a stretched membrane. The force which acts along the surface of a liquid, tending to contract its area to a minimum, is called the **surface tension** of the liquid.
The dimension of surface tension is $[MT^{-2}]$.
- Surface tension = $\frac{\text{force}}{\text{length}} = \frac{\text{workdone}}{\text{change in area}}$
- Unit of surface tension = newton/metre = joule/(metre)².
- Dimensions of surface tension = $\frac{MLT^{-2}}{L} = [MT^{-2}]$

- **Cohesive force** is the force of attraction between molecules of same substance.
- **Adhesive force** is the force of attraction between molecules of different substances.
- **Molecular range** $\approx 10^{-9}$ m. It depends upon material. It is equal to the maximum distance upto which the molecules attract each other. Also it is equal to the radius of sphere of influence.
- Cohesive force (F_c) or adhesive force (F_a) is inversely proportional to eighth power of the distance between the molecules.
- $F_c \propto \frac{1}{r^8}$. Also $F_a \propto \frac{1}{r^8}$.
- Due to property of surface tension, a liquid tends to minimize its free surface area.
- **Surface tension** is the molecular phenomenon.
- **Surface energy** : To increase the surface area of liquid work has to be done against the force of surface tension. This additional potential energy stored per unit area of the surface is called surface energy. It can be shown that the surface energy per unit area is numerically equal to the surface tension of liquid.
- **Angle of contact** : A liquid is to be kept in a vessel and thus, liquid is in contact with some solid surface. For a pair of solid and liquid, the angle of contact θ , is defined as the angle between tangent to the liquid surface drawn at the point of contact and the solid surface inside the liquid.
 If $\theta < 90^\circ$, the liquid will have a meniscus concave upwards.
 If $\theta > 90^\circ$, the liquid surface will have a meniscus convex upwards.
 If $\theta = 90^\circ$, the surface of liquid at the point of contact is plane.
- **Angle of contact, meniscus, shape of liquid surface**

Property	Angle of contact $< 90^\circ$	Angle of contact $= 90^\circ$	Angle of contact $> 90^\circ$
Substances	water and glass	water and silver	mercury and glass
Angle of contact	almost zero. acute angle	right angle = 90°	obtuse angle = 135°
Meniscus shape	concave	plane	convex
Capillary action	liquid rises	no effect	liquid falls
Sticking to solid	sticks/wets	does not wet	does not wet
Relation between F_a and F_c	$F_a > \frac{F_c}{\sqrt{2}}$ $F_a > F_c$	$F_a = \frac{F_c}{\sqrt{2}}$	$F_a < \frac{F_c}{\sqrt{2}}$ $F_c > F_a$
Shape of liquid surface	almost round	spreads on surface	flat

- **Capillarity** : A tube of very small radius is called a capillary. When such a clean tube of glass open at both ends is dipped vertically in water, the water rises in the tube upto

a certain height above the water level outside the tube. On the other hand, if the tube is dipped in mercury, the mercury level falls below the outside level. The phenomenon of rise or fall of the liquids in a capillary tube is called **capillarity**.

- **Zurin's law** : $Rh = \text{constant} \Rightarrow R_1h_1 = R_2h_2$
 $R =$ radius of capillary tube, $h =$ height of liquid in capillary tube.
- Liquid rises (water in glass capillary) or falls (mercury in glass capillary) due to property of surface tension.

$$T = \frac{R\rho gh}{2\cos\theta} \quad \text{where}$$

$R =$ radius of capillary tube, $h =$ height of liquid,

$\rho =$ density of liquid, $\theta =$ angle of contact,

$T =$ surface tension of liquid, $g =$ acceleration due to gravity.

- **Tube of insufficient length**

Liquid may rise to a height h but if the length of tube is less than this height, overflow of liquid does not occur. The liquid rises upto upper end and acquires a meniscus r' such that $r'h' = rh$.

- Tube kept in inclined position. The vertical height to which liquid rises remains the same.

$$\frac{h}{\cos\alpha} = l = \text{inclined length}$$

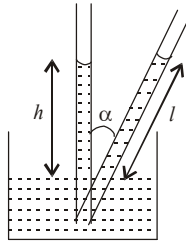

- **Excess pressure due to surface tension:**

(a) The pressure on concave side of a curved liquid surface is greater than the pressure on convex side.

(b) Excess pressure inside a liquid drop $P = 2T/R$, where R is the radius of drop. A drop has only one surface of contact of liquid and air.

(c) *Excess pressure inside a soap bubble* : A bubble has two surfaces of contact of soap and air.

Excess pressure $P = 4T/R$.

(d) Excess pressure in air bubble inside a liquid $P = 2T/R$.

- **Combination/spraying of drops-work done**

(a) When a number of smaller drops are combined into a bigger drop, volume remains constant but area decreases. Energy is released and temperature of bigger drop increases.

(i) Equate volume, $\frac{4}{3}\pi R^3 = n \times \frac{4}{3}\pi r^3$

$$n = \left(\frac{R}{r}\right)^3.$$

(ii) Decrease in surface area = $n \cdot 4\pi r^2 - 4\pi R^2 = 4\pi(nr^2 - R^2)$.

(iii) Work done = change in area \times surface tension

(iv) Work done is converted into heat, $W = JH$.

Thereby temperature of bigger drop increases.

Specific heat of water = $1 \text{ cal g}^{-1} \text{ }^\circ\text{C}^{-1}$.

Density of water = 1 gcm^{-3} .

$$J\left(\frac{4}{3}\pi R^3\right)(1)(1) \times \Delta\theta = W$$

$$\therefore \Delta\theta = \frac{3T}{J}\left(\frac{1}{r} - \frac{1}{R}\right)$$

(b) When a bigger drop of radius R is sprayed into a number of similar smaller drops, each of radius r , volume remains constant but surface area of drops increases. Energy is absorbed. Temperature of the system decreases.

(i) Equate volumes, $n \times \frac{4}{3}\pi r^3 = \frac{4}{3}\pi R^3$

$$n = \left(\frac{R}{r}\right)^3.$$

(ii) Increase in surface area = $n \cdot 4\pi r^2 - 4\pi R^2 = 4\pi(nr^2 - R^2)$

$$= 4\pi\left(\frac{R^3}{r^3} \cdot r^2 - R^2\right) = 4\pi R^3\left(\frac{1}{r} - \frac{1}{R}\right)$$

(iii) Work done = $T \times$ change in area $W = \text{energy} = 4\pi TR^3\left(\frac{1}{r} - \frac{1}{R}\right)$

(iv) Energy is absorbed. $W = JH$.

Thereby temperature of smaller drops falls.

$$J \times \left(\frac{4}{3}\pi R^3\right)(1)(1) \times \Delta\theta = W$$

$$\therefore \Delta\theta = \frac{3T}{J}\left(\frac{1}{r} - \frac{1}{R}\right).$$

(c) Workdone in blowing a liquid drop

$W = T \times$ change in surface area

or $W = T \times 4\pi(r_2^2 - r_1^2)$

If $r_2 = R, r_1 = 0$ or $W = 4\pi TR^2$.

(d) Workdone in blowing a soap bubble.

Soap bubble has two surfaces of contact.

$W = 2 \times T \times$ change in surface area

or $W = 2T \times 4\pi(r_2^2 - r_1^2)$ or $W = 8\pi T(r_2^2 - r_1^2)$

If $r_2 = R, r_1 = 0$.

$W = 8\pi TR^2$.

• **Radius of new bubble when two bubbles coalesce**

Let r_1 and r_2 be the radii of two bubbles. Let them coalesce into a bubble of radius r , under isothermal conditions. Let T denote the surface tension,

$$P_1 = \frac{4T}{r_1}, P_2 = \frac{4T}{r_2}, P = \frac{4T}{r}$$

By Boyle's law, $P_1V_1 + P_2V_2 = PV$

$$\left(\frac{4T}{r_1}\right)\left(\frac{4}{3}\pi r_1^3\right) + \left(\frac{4T}{r_2}\right)\left(\frac{4}{3}\pi r_2^3\right) = \frac{4T}{r}\left(\frac{4}{3}\pi r^3\right)$$

$$r_1^2 + r_2^2 = r^2.$$

- **Radius of interface**

Consider two soap bubbles of radii r_1 and r_2 in contact with each other. Let r denote the radius of the common boundary/interface.

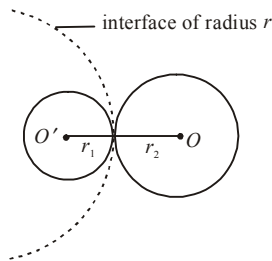

Let P_1 and P_2 denote the excess pressure on the two sides of the interface and let P denote the resultant excess pressure.

$$P = P_1 - P_2 \Rightarrow \frac{4T}{r} = \frac{4T}{r_1} - \frac{4T}{r_2} \Rightarrow \frac{1}{r} = \frac{1}{r_1} - \frac{1}{r_2}.$$

$$\text{Hence } r = \frac{r_1 r_2}{r_2 - r_1}.$$

- **Effect of temperature on surface tension**

- Surface tension of a liquid decreases with rise of temperature.
- An exception - Surface tension of molten cadmium or copper increases with increase in temperature.
- At critical temperature, surface tension of a liquid becomes zero.
- At boiling point, surface tension of a liquid becomes zero.
- At freezing point, surface tension becomes maximum.

- **Effect of impurity on surface tension**

- Soluble impurities cause increase in surface tension.
- Partially soluble impurities cause decrease in surface tension. Soaps, detergents, phenol reduce surface tension of water.

Some salient points about surface tension

- The angle of contact depends upon
 - The nature of solid and liquid in contact.
 - The given pair of the solid and the liquid
 - The impurities and the temperature
- The angle of contact lies between 0° and 180° .

- The angle of contact does not depend upon the inclination of the solid in the liquid.
- The rise in temperature increases angle of contact.
- Addition of soluble impurities increases angle of contact.
- The water proofing material increases the angle of contact. Acute angle is converted into obtuse angle.
- Addition of detergent, soap etc. to water decreases angle of contact as well as surface tension.
- The surface tension of the liquid decreases due to electrification. Soap bubble expands when given a charge. Due to charge, a normal force acts in the outward direction on liquid surface.
- Due to contamination, surface tension decreases. Dust particles and lubricating materials reduce surface tension.
- Under weightlessness (as in a satellite) liquid does not rise in a capillary tube and splits into minute droplets. If liquid state is maintained, the liquid rises to the top of capillary tube and the radius of liquid meniscus adjusts itself for equilibrium.

$$Rdgh = 2T\cos \theta \text{ when } Rh = \text{constant.}$$

- The force required to separate two glass plates, between which a liquid film is held is $\frac{2AT}{t}$ where t denotes thickness of the film. Obviously greater force is needed for thinner films.
- Force due to surface tension on a hemispherical soap bubble.
Force = $2T \times \text{circumference} = 2T \times 2\pi R = 4\pi RT$.
- For a liquid drop,

$$P = \frac{2T}{R}, \quad \text{Volume of drop} = V = \frac{4}{3}\pi R^3.$$

$$\therefore PV = \frac{2T}{R} \times \frac{4}{3}\pi R^3 = \left(\frac{8\pi T}{3}\right)R^2$$

$$\frac{PV}{R^2} = \frac{8\pi T}{3} = \text{constant}$$

$$\text{For two drops, } \frac{P_1V_1}{R_1^2} = \frac{P_2V_2}{R_2^2}.$$

- Force on annular disc, having radii R and r , floating on a liquid sphere of surface tension is equal to T .

$$T = \frac{\text{force}}{\text{length}} = \frac{F}{2\pi(R+r)}$$

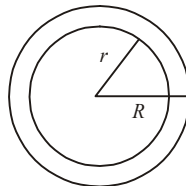

$$F = 2\pi T(R+r).$$

- When two soap bubbles of equal radii coalesce, then the shape of resultant surface shall be plane.

$$r = \frac{r_1 r_2}{r_2 - r_1} = \frac{r^2}{\text{zero}} = \text{infinity} = \text{plane surface}$$

- When wax is coated on a glass capillary tube, it becomes water- proof. The angle of contact increases and becomes obtuse. Water does not rise in it. Rather it falls in the tube by virtue of obtuse angle of contact.

HYDRODYNAMICS

Viscosity

- When a layer of a liquid slips or tends to slip on another layer in contact, the two layers exert tangential force on each other. The directions are such that the relative motion between the layers is opposed. This property of a liquid to oppose relative motion between the layers is called viscosity.

Coefficient of viscosity

- Tangential force/viscous drag $F = -\eta \cdot A \cdot \frac{dv}{dx}$
where dv/dx denotes velocity gradient between two layers of liquid each of area A .
 η = coefficient of viscosity of liquid.
- S.I. unit of η is decapoise = Nsm^{-2} or pascal-second.
c.g.s. unit of η is poise = dyne sec cm^{-2} .
- Dimensions of η = $[\text{ML}^{-1}\text{T}^{-1}]$.
- Viscosity is due to transport of momentum.
- The value of viscosity (and compressibility) for ideal liquid is zero.

Poiseuille's formula and liquid resistance

- Volume of liquid flowing per second V through a horizontal capillary tube of length l , radius r , across a pressure difference P , under streamline motion, is given by

$$V = \frac{\pi P r^4}{8 \eta l} = \frac{P}{R}$$

- Liquid resistance $R = \frac{8 \eta l}{\pi r^4}$.
- (i) Two capillary tubes are joined in series. $P = P_1 + P_2$ and V is same through the two tubes.
- (ii) Equivalent liquid resistance, $R_s = R_1 + R_2$.
- (i) Two capillary tubes are joined in parallel.

$$\text{Equivalent liquid resistance, } R_p = \frac{R_1 R_2}{R_1 + R_2}$$

$$\text{or, } \frac{1}{R_p} = \frac{1}{R_1} + \frac{1}{R_2}$$

- (ii) In parallel, $V = V_1 + V_2$ but pressure difference P is same across both tubes.

Stoke's law and terminal velocity

- Stoke's law relates the backward dragging force F acting on a small sphere of radius r moving through a viscous medium of viscosity η with the velocity v .

$$F = 6\pi\eta rv.$$

- Terminal velocity is the maximum constant velocity of sphere of density ρ which falls freely in a viscous medium of density ρ_0 .

$$v = \frac{2}{9} \cdot \frac{r^2(\rho - \rho_0)g}{\eta}.$$

- If $\rho > \rho_0$, the body falls downwards.
- If $\rho < \rho_0$, the body moves upwards with the constant velocity.

- If $\rho_0 \ll \rho$, $v = \frac{2r^2\rho g}{9\eta}$.

Factors affecting viscosity

- Effect of temperature**

- If temperature increases, viscosity of liquid decreases. Viscosity of water, for example, at 80°C falls to one-third of its value at 10°C .
- The rate of diffusion of gases and also viscosity of all gases increases with increase in temperature *i.e.* $\eta \propto \sqrt{T}$.

- Effect of pressure**

- If pressure increases, viscosity of liquid increases but viscosity of water decreases at few hundred atmosphere.
- Viscosity of gases remains constant at high pressure but in low pressure region the viscosity of gases is directly proportional to pressure.

Streamlined and turbulent flow

- When a liquid flows in such a way that each liquid particle when passed through the same point follows exactly the same path as followed by the proceeding particles when passed through the same point then the flow is said to be streamlined and the path is called **streamline**.
- The fluid flows in streamline only when its velocity is less than certain value called **critical velocity**. While the motion of the particles of the fluid are disorderly, if velocity is more than critical value, the disorder motion of fluid is called **turbulent flow**.

- Critical velocity**, $v_c = \frac{K \cdot \eta}{r \cdot \rho}$

where K = Reynold's number

η = coefficient of viscosity of liquid

r = radius of capillary tube

ρ = density of liquid.

- When $v \leq v_c$, the flow of liquid is streamlined. v_c denotes the maximum velocity of a liquid under streamline flow. Viscosity dominates the flow.

- When $v > v_c$, the flow of liquid is turbulent. Such a flow is dominated by density of the fluid while viscosity has little effect on it. Lava, for example, is highly thick fluid emerging from a volcano with high speed.
- **Reynold's number** = $K = \frac{v_c \cdot \rho \cdot r}{\eta}$
 - (i) $K = \frac{\text{Inertial force}}{\text{Viscous force}}$
 - (ii) For $K < 3000$, the flow of liquid is streamlined.
 - (iii) For $K > 5000$, the flow becomes turbulent.
 - (iv) K has no unit, no dimension. It is a pure number.
 - (v) For narrow tubes and water, $K \approx 1000$.
- **Equation of continuity** : Equation of continuity is a special case of general law of conservation of matter stated as “for a steady state flow of an ideal fluid (incompressible and non-viscous) in a pipe, the rate of mass flow across any cross section is constant. If two sections A_1 and A_2 at right angles to a tube of flow be considered at two different positions, then velocities of flow v_1 and v_2 respectively at these positions are related to the sections as $A_1 v_1 = A_2 v_2$. Thus, when fluid flows through a smaller cross-section its velocity increases. This is known as equation of continuity.
- A fluid in steady or streamline flow may possess any or all of the three types of energy :
 - (i) **Kinetic energy** : Kinetic energy per unit volume = $\frac{1}{2} \rho v^2$
 - (ii) **Potential energy** : Potential energy per unit volume = $\rho g h$
 - (iii) **Pressure energy** : Pressure energy of an incompressible fluid is because of its hydrostatic pressure P and pressure energy per unit volume = P .

Bernouilli's theorem

- It is the principle of conservation of energy for a flowing liquid. Under streamlined motion of a liquid, the sum total of pressure energy, kinetic energy and potential energy per unit volume at every point along its path remains constant.

$$\text{Mathematically, } P + \frac{1}{2} \rho v^2 + \rho g h = \text{constant} .$$

- At greater depth, P is large and so v is small. Liquids flow slow at greater depths. Deeper waters run slow accordingly.
- The theorem is applicable to ideal liquid *i.e.* a liquid which is non-viscous, incompressible and irrotational.

- It is expressed as follows also: $\frac{P}{\rho g} + h + \frac{1}{2} \frac{v^2}{g} = \text{a constant where}$

$$\frac{P}{\rho g} = \text{pressure head, } \frac{1}{2} \frac{v^2}{g} = \text{velocity head,}$$

$$h = \text{potential head.}$$

Torricelli's theorem and horizontal range

- $v = \sqrt{2gh}$ where $v =$ velocity of efflux.
- Velocity of efflux is the velocity acquired by a freely falling body in falling through a vertical distance h which is equal to depth of a hole, below free surface of liquid, from which liquid flows out.
- Horizontal range when water issues out of a hole at depth h below surface of water in a tank filled with water upto a height H . Water issues out from A .

It covers a vertical distance $= (H - h)$ before striking the ground. Time for this vertical

journey $= \sqrt{\frac{2(H - h)}{g}}$.

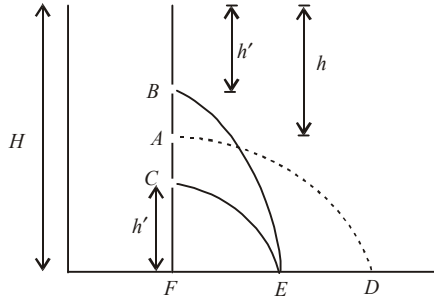

Horizontal velocity of water is velocity of efflux $= \sqrt{2gh}$.

Horizontal range $FD = \sqrt{2gh} \times \sqrt{\frac{2(H - h)}{g}}$

Range $R = FD = 2\sqrt{h(H - h)}$

• **Special case**

(i) For B , range $= 2\sqrt{h'(H - h')} = FE$

For C , range $= 2\sqrt{(H - h')h'} = FE$

Range is same whether the point is at distance h' below top or h' above bottom.

(ii) Maximum range

Range $R = 2\sqrt{h(H - h)}$

For maximum horizontal range, $\frac{dR}{dH} = 0$.

$R^2 = 4h(H - h)$

$2R \cdot \frac{dR}{dH} = 4(H - h) + 4h(-1)$

$$= 4H - 4h - 4h = 4H - 8h$$

$$0 = 4H - 8h \Rightarrow h = H/2.$$

Range is maximum when liquid issues from a point at mid-height of tank.

$$R_{\max} = 2\sqrt{\frac{H}{2}\left(H - \frac{H}{2}\right)} = H$$

same as height of tank itself.

Some salient points about viscosity

- The cause of viscosity in liquids is the cohesive forces among molecules.
- The cause of viscosity in gases is diffusion.
- The viscosity of water is much higher than that of air. Hence it is more difficult to run through water than in air.
- In heavy machines lubricating oils of high viscosity are used.
- In light machines low viscosity oils are used for lubrication.
- 1 poise = 0.1 pascal second.
- Coefficient of viscosity is zero for ideal fluids. Incidentally, their compressibility is also zero.
- For water, $\eta = 10^{-3}$ pascal second = 10^{-2} poise.
For glycerine, $\eta = 0.82$ pascal second = 8.2 poise.
- **Velocity gradient:** It is the relative velocity between two consecutive parallel liquid layers, unit distance apart, at right angles to the direction of flow of liquid. Its unit is (second)⁻¹. Its dimension is [T⁻¹].
- The path of liquid-stream issuing from a hole in a tall jar is parabolic.
- Two ping-pong balls freely suspended come closer when high speed air current is blown between them.
Pressure between the balls falls due to high air velocity.
- After terminal velocity is acquired, the acceleration of a body falling through viscous fluid is zero. Gravitational force and viscous force balance each other.

End

oscillations

- A motion which repeats itself in definite interval of time is known as **periodic motion** *e.g.*, motion of sun around earth, motion of simple pendulum, motion of arms of a clock etc.
- When a body moves to and fro on either side of a point in definite time interval, then this motion is said to be oscillatory or vibratory motion. Time taken by the body to complete one oscillation is known as **time-period** *e.g.*, motion of a mass suspended from a spring, motion of simple pendulum etc.
- Each vibratory motion is periodic but each periodic motion is not vibratory.
- The time after which the body retraces its path is called the **time-period** and the number of vibrations made in one second is called **frequency**.
frequency = $1/\text{Time period}$
- The physical quantity which varies uniformly with time in an oscillatory motion is called **displacement**. The maximum value of displacement is known as **amplitude**.
- A motion in which the acceleration of the body is proportional to its displacement from the mean position and is always directed towards the mean position is known as the **simple harmonic motion**.
- It has following characteristics :
 - (i) Motion is on both sides of mean position. The maximum displacement on one side of mean position is known as **amplitude**.
 - (ii) The body repeats its motion in a definite interval of time.
 - (iii) Acceleration is always proportional to the displacement and is directed opposite to it.
Acceleration $\propto (-) y$
 - (iv) The motion of foot of perpendicular dropped from the particle moving in a circle on the horizontal and vertical diameters is called S.H.M.
- The graphical representation of simple harmonic's motion

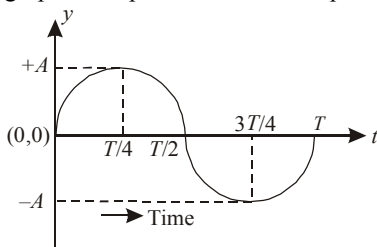

- Equation representing simple harmonic motion is

$$y = A\sin(\omega t + \phi)$$

where A = amplitude, ω = angular frequency, $(\omega t + \phi)$ is called the phase of the particle at any instant t and ϕ is the initial phase or epoch of the particle.

- If two particles executing S.H.M. cross their mean positions in same direction, then they are in same phase of vibration. If they cross the mean position in opposite directions then they are in opposite phase.
- The phase difference between two particles in same phase is 2π radian while the phase difference between the two particles in opposite phase is π radian.
- Velocity** of the particle

$$\frac{dy}{dt} = A\omega \cos \omega t \quad \text{or} \quad v = \omega \sqrt{(A^2 - y^2)}$$

- At $y = 0$ (i.e., at mean position) velocity is maximum and $v_{\max} = A\omega$.
- At $y = A$ (i.e., at extreme position) velocity is minimum and $v_{\min} = 0$.
- Kinetic energy, $K = \left(\frac{1}{2}\right)mv^2 = \left(\frac{1}{2}\right)m\omega^2(A^2 - y^2)$

The kinetic energy is maximum at $y = 0$, i.e., at mean position and

$K_{\max} = \left(\frac{1}{2}\right)m\omega^2A^2$, similarly the kinetic energy is minimum at $y = A$, i.e., at extreme position and $K_{\min} = 0$.

- Acceleration = $\frac{d^2y}{dt^2} = -\omega^2A\sin \omega t$

$$\therefore \text{Acceleration} = -\omega^2y$$

The negative sign indicates that the acceleration is directed towards the mean position.

- Acceleration is maximum at extreme position (i.e., at $y = A$) and maximum acceleration = ω^2A .
- Acceleration is minimum at $y = 0$, i.e., at mean position and the minimum acceleration is zero.
- The graphical representation of displacement, velocity and acceleration.

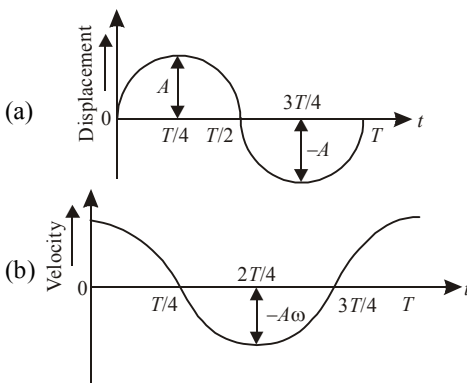

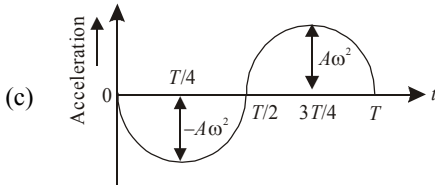

- It is important to note that the acceleration is maximum at a place where the velocity is minimum and vice-versa.
- Potential energy , $U = \frac{m\omega^2 y^2}{2}$
- Maximum potential energy is at $y = \pm A$ and is given by $U_{\max} = \left(\frac{1}{2}\right) m\omega^2 A^2$
- Minimum potential energy is at $y = 0$ and is given by $U_{\min} = 0$.
- $E = \text{K.E.} + \text{P.E.}$

$$E = \left(\frac{1}{2}\right) m\omega^2(A^2 - y^2) + \left(\frac{1}{2}\right) m\omega^2 y^2 \quad \text{or} \quad E = \left(\frac{1}{2}\right) m\omega^2 A^2$$

$$E = 2\pi^2 mA^2 n^2$$

where n is the frequency of vibrations. It is clear that the total energy of a particle executing S.H.M. remains constant during the motion, it changes from potential to kinetic and vice-versa.

- The curves representing K.E., P.E. and total energy are shown in figure.

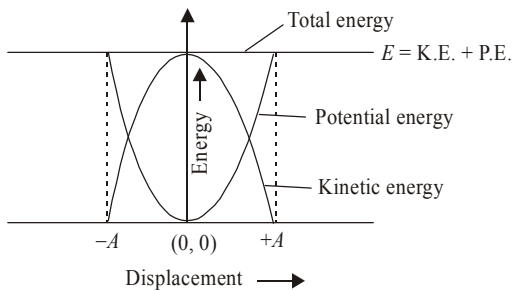

- For executing simple harmonic motion, a system must possess inertia and elasticity.
- For executing simple harmonic motion, a particle may start swinging from mean position. Its equation is $y = A\sin(\omega t + \phi) = A\sin\omega t$ when ϕ is zero.
- For a particle executing simple harmonic motion, the phase difference between
 - (a) displacement and instantaneous velocity = $(\pi/2)$ radian
 - (b) instantaneous velocity and acceleration = $(\pi/2)$ radian
 - (c) acceleration and displacement = π radian.
- For a particle executing simple harmonic motion, the nature of graph of velocity as a function of displacement is elliptical.
- During simple harmonic motion, a particle traverses a distance equal to half its amplitude from its equilibrium position in $(T/12)$ sec where T denotes the periodic time.

- During simple harmonic motion, a particle traverses a distance equal to half its amplitude from its extreme position in $(T/6)$ sec where T denotes the periodic time.
- During simple harmonic motion, a particle may start swinging from an extreme position. Its equation is $y = A\cos(\omega t + \phi)$.
 $y = A\cos\omega t$ when $\phi = 0$.
- At position of equilibrium under simple harmonic motion, the magnitude of velocity is maximum ($= \omega A$) while magnitudes of displacement and acceleration are zero.
- At extreme position under simple harmonic motion, the velocity of the particle is zero while magnitudes of acceleration ($= \omega^2 A$) and displacement ($= A$) are maximum.
- A heavy point mass suspended from a rigid support by means of an elastic inextensible string constitutes an ideal **simple pendulum**.
- Ideal simple pendulum is not a practical possibility therefore a heavy metal sphere is suspended by a light thread from a rigid support.
- The metal sphere is known as bob and the point from which the pendulum is suspended is called centre of suspension. The distance between the centre of suspension and centre of gravity of the bob is known as the effective length of the pendulum.
- The time period of the simple pendulum is $T = 2\pi\sqrt{\left(\frac{l}{g}\right)}$.

- **Simple pendulum of large length**

- (a) When length of simple pendulum is not negligible in comparison to radius of earth R ,

$$T = 2\pi\sqrt{\frac{Rl}{g(l+R)}}$$

- (b) For simple pendulum of infinite length,

$$T = 2\pi\sqrt{\frac{R}{g}} = 84 \text{ minute approximately.}$$

- **Simple pendulum in horizontally accelerated vehicle**

Let a represent the horizontal acceleration of a vehicle.

$$\therefore g' = \sqrt{a^2 + g^2}$$

$$\therefore T = 2\pi\sqrt{\frac{l}{\sqrt{a^2 + g^2}}}$$

- **Pendulum in a vehicle sliding down a plane**

Let $\theta =$ inclination of plane $T = 2\pi\sqrt{\frac{l}{g\cos\theta}}$.

- **Isochronous vibrations of pendulum**

The time period of a pendulum does not depend on its amplitude when amplitude is short, in a permitted range. The vibrations are said to be isochronous as same time is taken in completing an amplitude, whether large or small (within range).

- If the acceleration due to gravity is constant at a place then the time-period of the simple pendulum is directly proportional to the square-root of length of the pendulum $T \propto \sqrt{l}$

- The time-period of the simple pendulum is independent of the mass and material of the bob.
- **Seconds pendulum** is the simple pendulum, having a time-period of 2 second. Its effective length is 99.992 cm or approximately one metre on earth.
- A bob suspended by a metal wire fixed at one end and rotating a horizontal circle at the other end constitutes conical pendulum.

It is shown in figure.

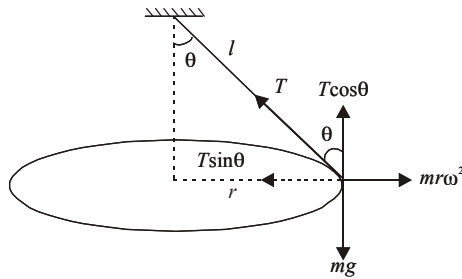

The tension ‘ T ’ in the wire can be resolved into two components

- $T \cos \theta$ is vertical component.
- $T \sin \theta$ is horizontal component.

$$\therefore T \cos \theta = mg$$

and $T \sin \theta = mr\omega^2$ in equilibrium position.

- **Compound pendulum** is a rigid body capable of rotating in a vertical plane about a horizontal axis passing through any point in the body. Its time-period is given by

$$T = 2\pi \sqrt{\left(\frac{I}{mgd}\right)}$$

where I is the moment of inertia of the body about an axis passing through the centre of suspension, m is the mass of body and d is the distance of centre of gravity from the centre of suspension.

- Time period of **torsional pendulum** $T = \frac{2\pi}{\omega} = 2\pi \sqrt{\frac{I}{C}}$
where C is restoring couple per unit twist and I is the moment of inertia of moving system about the axis of rotation.
- Springs have a property that when they are stretched or compressed then a restoring force is immediately developed in them which tries to bring them back to their initial states. If the extension produced in the spring is x , then $F = -kx$
where k is a constant known as spring constant or force constant or stiffness constant.

$$k \text{ is numerically equal to } = \frac{F}{x} = \frac{mg}{x}$$

- Its units are newton/metre. The time period of a spring loaded by mass m is

$$T = 2\pi \sqrt{\left(\frac{m}{k}\right)} = 2\pi \sqrt{\left(\frac{x}{g}\right)}$$

- If two springs are in series and they are made to oscillate then their time-period is given by

$$T = 2\pi \sqrt{\left[\frac{m(k_1 + k_2)}{k_1 k_2} \right]}$$

- If two springs are joined in parallel then the time-period is given by

$$T = 2\pi \sqrt{\left[\frac{m}{(k_1 + k_2)} \right]}$$

- In realistic systems, resistive forces such as friction, are present and they retard the motion of the system. The mechanical energy of the system diminishes in time and the motion is said to be damped.

- The angular frequency of vibration of a damped system in the form $\omega = \sqrt{\omega_0^2 - \left(\frac{b}{2m}\right)^2}$

where $\omega_0 = \sqrt{\frac{k}{m}}$ represents the angular frequency of oscillation in the absence of a resistive force (the undamped oscillation).

- When $b = 0$, the resistive force is zero and the system oscillates with angular frequency ω_0 called the natural frequency.
- When $b/2m = \omega_0$, the system does not oscillate and is said to be critically damped.
- When $b/2m > \omega_0$, the medium is highly viscous and the parameters meet the condition $b/2m > \omega_0$. The system is overdamped.
- It is possible to compensate for the transformation of energy by driving the system with an external periodic force. The oscillator in this case is undergoing forced oscillation.

- **Liquid in U-tube**

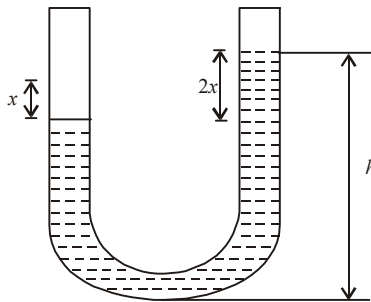

$$T = 2\pi \sqrt{\frac{h}{g}}$$

or
$$T = 2\pi \sqrt{\frac{l}{2g}}$$

where $l =$ total length of liquid column $= 2h$
 $h =$ height of liquid column in any one limb.

- Rectangular block floating in a liquid

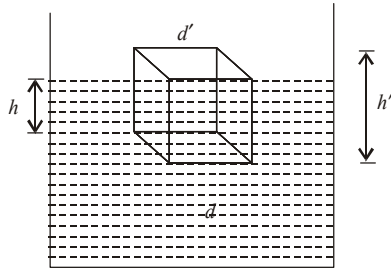

$$T = 2\pi \sqrt{\frac{h'd'}{gd}}$$

where d = density of liquid

d' = density of the block

h' = height of the block

End

waves

- A **sound wave** is a longitudinal wave through an elastic medium, where the oscillations of the particles in the medium are along the path of progress of the wave.
- Sound waves can travel through any material medium (that is, solids, liquids and gases) with speed that depends on the properties of the medium.
- As sound waves travel through a medium the particles in the medium vibrate to produce density and pressure changes along the direction of motion of the wave.
- The displacement that occurs as a result of sound waves involve the longitudinal displacement of individual molecules from their equilibrium position. This results in a series of high and low pressure regions called **compressions** and **rarefactions**, respectively.
- In a compression, distance between any two consecutive particles of medium is less than their normal distance. Therefore density is more than the normal density.
- In a rarefaction, distance between any two consecutive particles of medium is more than the normal distance, density is less than the normal density.
- Distance between two consecutive compressions or rarefactions is equal to the **wavelength** of the wave.
- Sound waves show both the phenomenon of **reflection** and **refraction**.
- When sound waves travelling in a medium strikes the surface separating the two media, a part of incident wave is reflected back into initial medium obeying ordinary laws of reflection while the rest is partly absorbed and partly refracted or transmitted into second medium.
- When a sound wave gets reflected from a rigid boundary, the reflected wave interferes with the incoming wave to produce zero displacement at the rigid boundary. This implies that the phase of wave is reversed but the nature of sound wave does not change. *i.e.* on reflection, the compression is reflected back as compression and rarefaction as rarefaction.
- A sound wave is also reflected if it encounters a rarer medium or free boundary. In this case, there is no change in the phase of wave but the nature of sound wave is changed *i.e.* on reflection the compression is reflected as rarefaction and vice versa.
- When sound wave passes from one homogeneous medium to another homogeneous medium, it deviates from its path. This is called as **phenomenon of refraction**. If i and r are the angle of incidence and angle of refraction, then according to **Snell's law**,

$$\frac{\sin i}{\sin r} = \frac{v_1}{v_2} = \text{constant} ,$$

where v_1 and v_2 are the velocities of sound in first and second medium respectively.

Sound waves

- **Sound waves** are mechanical longitudinal waves.
- **Light waves** are electromagnetic transverse waves.
- Sound needs a medium for propagation. The medium should have inertia (or density), elasticity and continuity. Velocity of sound in vacuum is zero.
- (i) **Sub-sonic/infrasonic** - frequency less than 20 hertz.
(ii) **Sonic/sound** - frequency from 20 Hz to 2000 Hz.
(iii) **Ultrasonic** - frequency above 20,000 hertz.
(iv) **Hypersonic** - frequency above 10^8 hertz.
- If v_s = velocity of sound in solids,
 v_l = velocity of sound in liquids,
 v_g = velocity of sound in gases,
then $v_s > v_l > v_g$.
Sound travels fastest in solids.
- Sound waves do not undergo polarisation.
Transverse waves only get polarised.
- (i) Velocity of sound in air ≈ 332 m/s.
(ii) Velocity of sound in water ≈ 1400 m/s
(iii) Velocity of sound in steel ≈ 5000 m/s.
- Sound exhibits reflection, refraction, interference and diffraction but not polarisation.

Velocity of sound

- **Newton's formula** : $v = \sqrt{\frac{E}{D}}$, where E denotes modulus of elasticity and D denotes density of medium.
- **Laplace's correction**
For gases, $E =$ coefficient of adiabatic elasticity. $E = \gamma P$.

$$v = \sqrt{\frac{\gamma P}{D}}, \quad \gamma \text{ denotes adiabatic constant} = \frac{C_P}{C_V}.$$

- **Effect of temperature on velocity**
When temperature increases, volume increases and density decreases.

$$\frac{v_2}{v_1} = \sqrt{\frac{D_1}{D_2}}.$$

$$D_0 = D_t(1 + \beta t) \quad \text{or} \quad D_t = D_0(1 - \beta t).$$

where β denotes coefficient of cubical expansion. Velocity increases if temperature rises.

$$\frac{v_2}{v_1} = \sqrt{\frac{T_2}{T_1}}.$$

- **Effect of pressure**

P/D remains constant. Pressure has no effect on the velocity of sound.

- **Effect of humidity**

When humidity in air increases, its density decreases and so velocity of sound increases.

- For solids, $v = \sqrt{\frac{Y}{D}}$. For liquids, $v = \sqrt{\frac{E}{D}} = \sqrt{\frac{K}{D}}$.

Wave motion

- Particles execute simple harmonic motion about their mean positions but they are not bodily carried away.
- Energy or momentum is transferred to the neighbouring particles of the medium as wave proceeds.
- There is a continuous phase difference among successive particles of the medium.
- Alternate compressions and rarefactions comprise **longitudinal waves**. They involve changes in pressure and volume. The medium of propagation must possess elasticity of volume. They are set up in solids, liquids and gases.
- **Transverse waves** travel in the form of crests and troughs set up alternatively. The medium must possess the elasticity of shape. There is no change in density of medium. These waves can be set up in solids, on surface of liquids but never in gases. Transverse waves undergo polarisation as against longitudinal waves which do not get polarised.
- **Wave number** : Number of waves in unit length. It is measured in $(\text{metre})^{-1}$.
- **Particle velocity** = dy/dt .
It is the velocity of the particle executing simple harmonic motion. y denotes displacement at any instant.
- **Wave velocity** = $v = n\lambda = \lambda/T$
It is the velocity with which the disturbance travels in the medium. It is constant for a wave motion.
- Particle velocity changes with time but the wave velocity is constant.
- Acceleration of wave is zero but acceleration of particle is not zero.

- **Differential equation of wave motion** $\frac{d^2y}{dx^2} = \frac{1}{v^2} \cdot \frac{d^2y}{dt^2}$.

Relation between phase difference, path difference and time difference

- Phase difference of 2π radian is equivalent to a path difference of λ and a time difference of period T .

$$2\pi \Rightarrow \lambda \Rightarrow T$$

- Phase difference (ϕ) = $\frac{2\pi}{\lambda} \times \text{path difference } (x) \Rightarrow \phi = \frac{2\pi x}{\lambda} \Rightarrow x = \frac{\phi\lambda}{2\pi}$.
- Phase difference (ϕ) = $\frac{2\pi}{T} \times \text{time difference } (t) \Rightarrow \phi = \frac{2\pi t}{T} \Rightarrow t = \frac{T\phi}{2\pi}$.

- Time difference (t) = $\frac{T}{\lambda} \times$ path difference (x) $\Rightarrow t = \frac{Tx}{\lambda} \Rightarrow x = \frac{\lambda t}{T}$.
- (i) For a wave, velocity (v) = frequency (n) \times wavelength (λ)
 $v = n\lambda$
- (ii) Angular speed, $\omega = 2\pi n = \frac{2\pi}{T} = \frac{2\pi v}{\lambda}$.

Progressive wave

- The equation of a plane progressive simple harmonic wave travelling along positive direction of X -axis is

$$y = a \sin(\omega t - kx) \Rightarrow y = a \sin \frac{2\pi}{\lambda} (vt - x) \Rightarrow y = a \sin 2\pi \left(\frac{t}{T} - \frac{x}{\lambda} \right)$$

where y = displacement of particle at time t

$a = y_{\max}$ = amplitude of vibration of particle

v = velocity of wave = $n\lambda$

λ = wavelength of wave

T = time period of wave

k = propagation constant of wave

x = distance of particle from origin of wave

- Put $x = -x$, if the wave travels in the negative direction of x -axis.
- Propagation constant of wave motion = k .
- $k = \frac{2\pi}{\lambda}$ = phase difference between two vibrating particles unit distance apart.

- Maximum value of $y = a$ = amplitude.

(i) dy/dt = velocity of particle.

This may not be confused with velocity of wave. Infact velocity of wave is v and this remains constant with respect to time. The particle velocity dy/dt changes with time.

$$\frac{dy}{dt} = \left(\frac{2\pi v}{\lambda} \right) a \cos \frac{2\pi}{\lambda} (vt - x)$$

(ii) $\left(\frac{dy}{dt} \right)_{\max} = \frac{2\pi v a}{\lambda} = 2\pi n a = \omega a$

- Acceleration of particle = $\frac{d^2 y}{dt^2}$, $\frac{d^2 y}{dt^2} = -\omega^2 a \sin \frac{2\pi}{\lambda} (vt - x)$
- (i) Maximum value of $\frac{d^2 y}{dt^2} = -\omega^2 a$.

Echo

- Sound persists on ear for 0.1 sec.
Velocity of sound in air = 330 m/s.
Distance covered by the sound = $330 \times 0.1 = 33$ m.
Distance between source of sound and reflector = 16.5 m

- Let the first echo be heard after t_1 sec.
Let the second echo be heard after t_2 sec.
Then the third echo will be heard after $(t_1 + t_2)$.
- **Articulate sound :** The sound produced by human beings is called articulate sound. A person can emit 5 syllables in one second. Each syllable is produced in 0.2 second.
Distance travelled by sound = $0.2 \times 330 = 66$ m.
Reflector should be at a distance = 33 m from person.

Stationary waves

- Stationary waves/standing waves are produced by superposition of two identical waves along an axis in opposite directions.

$$y_1 = a \sin(\omega t - kx)$$

$$y_2 = a \sin(\omega t + kx)$$
 Equation of stationary waves, $y = y_1 + y_2$

$$y = a \sin(\omega t - kx) + a \sin(\omega t + kx)$$

$$y = (2a \cos kx) \sin \omega t = A \sin \omega t$$
 Here $A = 2a \cos kx$ denotes amplitude of stationary wave. It depends on x , the position of particle.
- Energy is not transferred across a plane in stationary waves. Energy is transferred onwards in progressive waves.

Nodes and antinodes

- Nodes and antinodes are alternatively placed in stationary waves.
- Between two nodes, there is an antinode. Between two antinodes, there is a node.
- Distance between two consecutive nodes = $\lambda/2$.
- Distance between two consecutive antinodes = $\lambda/2$.
- Distance between a node and adjoining antinode = $\lambda/4$.
- At nodes, amplitude is zero, strain is maximum, pressure and density variations are maximum.
- At antinodes, amplitude is maximum, strain is minimum, the variations in pressure and density are minimum.
- All particles between two consecutive nodes vibrate in the same phase. However, particles on two sides of a node vibrate in mutually opposite phases.
- Two consecutive nodes are separated by $\lambda/2$.
Three consecutive nodes are separated by $2\lambda/2$.

$$n \text{ consecutive nodes are separated by } \frac{(n-1)\lambda}{2}.$$

Tuning fork

- Frequency of a tuning fork $n = \frac{kt}{l^2} \sqrt{\frac{Y}{\rho}}$, where
 t = thickness of prong

l = length of prong

Y = Young's modulus of material

ρ = density of material

k = a constant

Accordingly tuning forks of higher frequencies are small and thick.

- Stationary waves are set up in a vibrating tuning fork. Two antinodes are at free ends of prong and third antinode is at junction point of stem and U-shaped body. Two nodes are situated on the two sides of central antinode (at junction point).
- The prongs execute transverse vibrations whereas the stem executes longitudinal vibrations.
- Tuning forks produce pure notes of sound.
- A vibrating tuning fork sets up longitudinal waves in air. Interference occurs between waves set up by the two prongs. In one rotation, four points of loud sound and four points of silence are produced. Loud sound is due to constructive interference while silence is due to destructive interference.
- Frequency of a tuning fork increases when the prong is filed. The decrease in length of prong results in increase in frequency of tuning fork.

$$n = \frac{kt}{l^2} \sqrt{\frac{Y}{\rho}} \Rightarrow n \propto \frac{1}{l^2}.$$

- Frequency of a tuning fork decreases when the prong is loaded with wax.
- The antinodes at the free ends communicate waves into resonance tube.
- The antinodes at the central point communicate waves to the box/string of sonometer.
- The frequencies of the forks are chosen from notes of musical scale. The frequencies are 256, 288, ..., 512 Hz.

Interference

- **Interference of sound waves :** When two sound waves of same frequency travel simultaneously in a medium in the same direction, then at some points both the waves produce compressions or rarefactions *i.e.* they meet in the same phase. At these points the amplitude is equal to the sum of the amplitudes of the two waves and intensity of sound is maximum.
- At some other points one wave produces compressions and at the same time the other wave produces rarefactions *i.e.* the waves meet in opposite phase. The amplitude at these points is equal to the difference of the amplitudes of the two waves and the intensity of sound is minimum.
- In order to observe the phenomenon of interference between two sound waves, the following conditions must be fulfilled:
 - (a) The phase difference between the waves must remain constant.
 - (b) The amplitudes of the two waves must be nearly equal.
 - (c) The displacement produced by the two waves should be along the same straight line in the same direction.

- **Constructive interference:**

(i) Phase difference between two waves = $0, 2\pi, 4\pi$.

(ii) Maximum amplitude = sum of component amplitudes

$$= (a + b) = 2a \text{ if } a = b.$$

(iii) Intensity \propto (amplitude)² \propto $(a + b)^2 \propto 4a^2$.

A loud sound is produced.

(iv) In general, amplitude = $\sqrt{a^2 + b^2 + 2ab \cos \phi}$.

- **Destructive interference:**

(i) Phase difference between two waves = $\pi, 3\pi, 5\pi$.

(ii) Minimum amplitude = difference of component amplitudes

$$= (a - b) = \text{zero if } a = b.$$

(iii) Intensity \propto (amplitude)² \propto $(a - b)^2$

Intensity becomes zero if $a = b$. Complete silence is produced as a result.

A low sound is produced if $a \neq b$.

- Quincke's tube demonstrates interference.
- A vibrating tuning fork, when rotated near ear, produces loud sound and silence due to constructive and destructive interference.
- The frequencies of two interfering waves should be exactly equal.
- The two amplitudes may or may not be equal.
- Phase difference = 0 or (even π) for constructive interference
= (odd π) for destructive interference.

Beats

- The phenomenon of alternate waxing and waning of sound produced by superposition of two similar waves, having slightly different frequencies, along same axis in same direction is called **beats**.
- The two waves should have slightly different frequencies. Let n_1 and n_2 represent frequencies.
- The difference of frequencies should not be more than 10. Sound persists on human ear drums for 0.1 second. Hence beats will not be heard if the frequency difference exceeds 10.
- Number of beats heard per second = $n_1 - n_2$
= difference of frequencies of two waves
- **Beat frequency** = number of beats heard per second.
- **Beat period** = reciprocal of beat frequency
= time interval between two consecutive beats.
- Maximum amplitude = $(a_1 + a_2)$
= sum of amplitudes of two waves
= $2a$ if $a_1 = a_2$.
- Maximum intensity = (maximum amplitude)² = $(a_1 + a_2)^2$.

- For loudness, time intervals are $\frac{1}{n_1 - n_2}$, $\frac{2}{n_1 - n_2}$

In general, $t = \frac{r}{(n_1 - n_2)}$ where $r = 1, 2, 3, \dots$

- For faint sound, $t = \frac{2r+1}{2(n_1 - n_2)}$, $r = 0, 1, 2, 3, \dots$
- Minimum amplitude = $(a_1 \sim a_2) = \text{zero}$ if $a_1 = a_2$.
- Minimum intensity = $(\text{minimum amplitude})^2 = (a_1 - a_2)^2$.

Lissajous figure

- **Lissajous figures** are obtained when two simple harmonic waves are superposed at right angles to each other.
- The shape of Lissajous figure depends upon amplitudes, frequencies and phase difference between the two waves.
- **Straight line** : If phase difference = $0, \pi, 2\pi, 3\pi, \dots$ radian, Lissajous figure is a straight line.
- **Straight ellipse** : If phase difference = $\pi/2, 3\pi/2, 5\pi/2 \dots$ radian. Lissajous figure is an ellipse which is straight.
- **Circle** : If phase difference = $\pi/2, 3\pi/2, 5\pi/2 \dots$ radian and amplitudes of two waves are equal, Lissajous figure is a circle.
- **Tilted/oblique ellipse** : If phase difference = $\pi/4, 3\pi/4, 5\pi/4, \dots$ Lissajous figure is an oblique ellipse.
- **Parabola and figure of 8** : If frequency ratio is $1 : 2$, Lissajous figure may be a parabola or a figure of 8 depending upon the phase difference between two waves.
- Frequencies of two waves should be equal for straight line, ellipse and circle to appear as Lissajous figure.
- For circle the two waves should have equal amplitudes. Frequencies = equal, amplitudes = equal, phase difference = $\pi/2$.

Open and closed pipes - resonance tube

- Longitudinal stationary waves are set up in open and closed pipes.
- At each open end, an antinode is formed. At closed end, a node is formed.
- **Fundamental note** - It is the sound of lowest frequency produced in fundamental mode of vibration of a system.
- **Overtone** - Tones having frequencies greater than the fundamental note are called overtones.
- **Harmonics** - When the frequencies of overtones are integral multiples of the fundamental, then they are known as harmonics. Thus the note of lowest frequency (n) is called fundamental note or first harmonic. The note of frequency $2n$ is called second harmonic or first overtone.

• **Open organ pipe**

(i) n_1 = frequency of fundamental = frequency of first harmonic

$$\therefore n_1 = \frac{v}{\lambda_1} = \frac{v}{2l}$$

(ii) n_2 = frequency of second harmonic
= frequency of first overtone

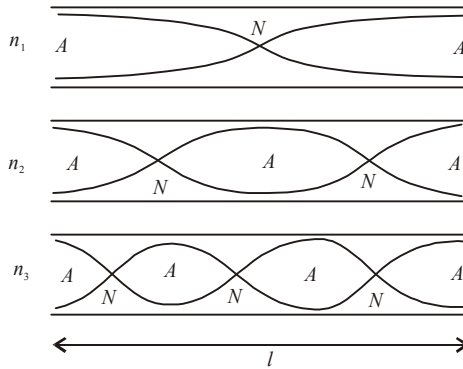

$$\therefore n_2 = \frac{v}{\lambda_2} = \frac{2v}{2l} = 2n_1$$

(iii) Frequency of r^{th} harmonic = frequency of $(r - 1)^{\text{th}}$ overtone $n_r = r \left(\frac{v}{2l} \right) = rn_1$

(iv) Thus all the harmonics *i.e.* frequencies $n_1, 2n_1, 3n_1, 4n_1$ are present in open organ pipe.

(v) In an open organ pipe, in the p^{th} harmonics, number of nodes = p , number of antinode = $(p + 1)$, number of loops = $(p - 1)$. A loop is formed between two adjoining nodes.

• **Closed organ pipe**

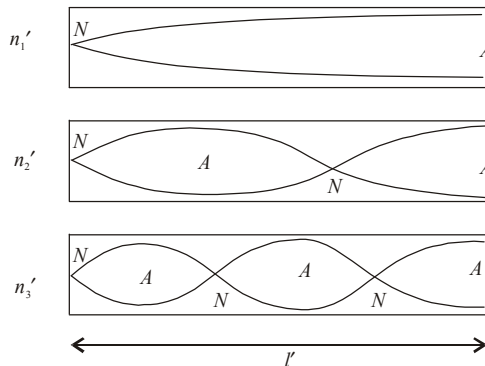

(i) n_1' = frequency of fundamental = frequency of first harmonic

$$\therefore n_1' = \frac{v}{\lambda_1'} = \frac{v}{4l'}$$

(ii) n_2' = frequency of first overtone $n_2' = \frac{v}{\lambda_2'} = \frac{3v}{4l'} = 3n_1'$
= frequency of third harmonic.

(iii) Frequency of second overtone $n'_3 = \frac{v}{\lambda'_3} = \frac{5v}{4l'} = 5n'_1$

This is frequency of fifth harmonic.

(iv) Frequency of r^{th} overtone = frequency of $(2r - 1)^{\text{th}}$ harmonic

$$n'_r = (2r - 1) \frac{v}{4l'} = (2r - 1)n'_1.$$

(v) Thus only odd harmonics *i.e.* frequencies $n'_1, 3n'_1, 5n'_1 \dots$ are present in closed pipes.

(vi) In r^{th} harmonic, number of nodes and antinodes are equal.

(vii) Suppose length of open pipe = l_o ,

fundamental frequency = n_o , length of closed pipe = l_c , fundamental frequency = n_c

$$\text{If } n_o = n_c, \frac{v}{2l_o} = \frac{v}{4l_c} \Rightarrow l_o = 2l_c.$$

$$\text{or if } l_o = l_c, \frac{n_o}{n_c} = \frac{v}{2l_o} \times \frac{4l_c}{v} = 2 \cdot \frac{l_c}{l_o} = 2, \quad n_o = 2n_c$$

- **End-correction**

(i) Antinode is not formed exactly at open end. It is slightly displaced away from open end. This distance is called end-correction. Let it be represented by x .

(ii) End-correction = $2x$ for open pipe. There are two open ends.

(iii) End-correction = x for closed pipe. There is one open end.

(iv) End-correction depends upon internal radius R of organ pipe. Thus $x = 0.6R$.

- Factors on which frequency of pipe depends

(i) length of air column, $n \propto \frac{1}{l}$

(ii) radius of air column, $n \propto \frac{1}{r}$

(iii) velocity of sound in air column, $n \propto v$

(iv) temperature of air column, $n \propto \sqrt{T}$

(v) pressure of air inside air column, $n \propto \sqrt{P}$

(vi) density of air, $n \propto \frac{1}{\sqrt{\rho}}$

Generally speaking, $n \propto \frac{v\sqrt{TP}}{lr\sqrt{\rho}} \propto \frac{v}{lr} \sqrt{\frac{TP}{\rho}}$.

- **Resonance tube**

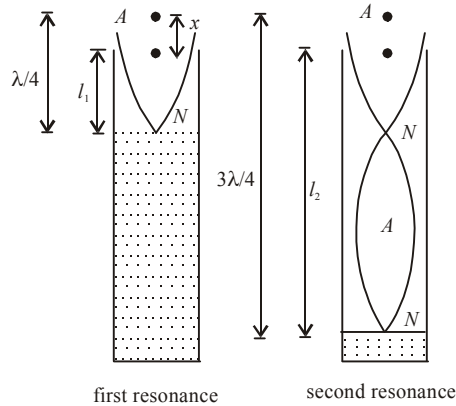

(i) It is an example of a closed organ pipe. Water level acts as reflector and provides closed end.

(ii) For first resonance, $\frac{\lambda}{4} = l_1 + x$... (i)

For second resonance, $\frac{3\lambda}{4} = l_2 + x$... (ii)

$$\therefore \lambda = 2(l_2 - l_1).$$

Velocity of sound = $n\lambda$

$$v = 2n(l_2 - l_1).$$

(iii) End-correction

Eliminate λ from (i) and (ii)

$$x = \frac{l_2 - 3l_1}{2}.$$

(iv) At resonance, frequency of tuning fork and the frequency of air column become equal. Amplitude of vibration of air column becomes large and a loud sound is produced at resonance.

Transverse vibration of strings - Sonometer

- Velocity of a transverse wave in stretched string = v

$$v = \sqrt{\frac{T}{\mu}} \text{ where } T \text{ denotes tension and } \mu \text{ denotes mass per unit length of string.}$$

- $\mu = \frac{\text{mass of string}}{\text{length of string}} = \frac{\text{volume} \times \text{density}}{l}$

$$\mu = \frac{(\pi R^2 l) \rho}{l} = \pi R^2 \rho.$$

$$v = \sqrt{\frac{T}{\pi R^2 \rho}} = \frac{1}{R} \cdot \sqrt{\frac{T}{\pi \rho}}$$

- Frequency of fundamental note = frequency of first harmonic

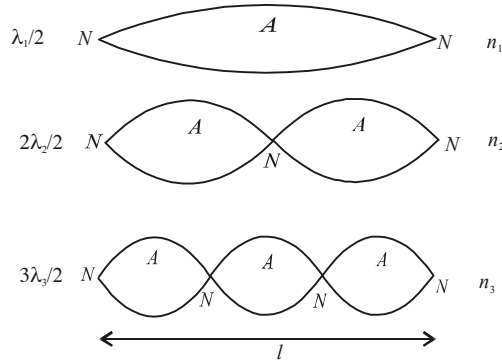

$$n_1 = \frac{v}{\lambda_1} = \frac{v}{2l} = \frac{1}{2l} \sqrt{\frac{T}{\mu}}$$

n_2 = frequency of second harmonic = frequency of 1st overtone

$$n_2 = \frac{v}{\lambda_2} = 2 \cdot \frac{v}{2l} = 2n_1$$

Similarly, frequency of 3rd harmonic or 2nd overtone = $n_3 = \frac{v}{\lambda_3} = 3n_1$

- **Laws of vibration of strings**

(i) Law of length, $n = \frac{1}{2l} \sqrt{\frac{T}{\mu}} \therefore n \propto \frac{1}{l}$

(ii) Law of tension, $n \propto \sqrt{T}$

(iii) Law of mass per unit length of string, $n \propto \frac{1}{\sqrt{\mu}}$

(iv) Since $\mu = \pi R^2 \rho$, $n = \frac{1}{2Rl} \sqrt{\frac{T}{\pi \rho}}$.

Law of radius of string, $n \propto \frac{1}{R}$.

$$\frac{n_1}{n_2} = \frac{R_2}{R_1}$$

(v) Law of density of material of wire, $n \propto \frac{1}{\sqrt{\rho}}$

$$\frac{n_1}{n_2} = \sqrt{\frac{\rho_2}{\rho_1}}$$

(iv) Law of loops (p) for a given length and given frequency.

$$p\sqrt{T} = \text{constant} \Rightarrow \frac{p_1^2}{p_2^2} = \frac{T_2}{T_1}$$

This is Melde's law.

Melde's experiment

- In longitudinal mode, vibrations of the prongs of tuning fork are along the length of the string. Frequency of vibration of string = $\frac{\text{frequency of tuning fork}}{2}$.

$$n_L = \frac{p}{l} \sqrt{\frac{T}{\mu}}$$

- In transverse mode, vibrations of tuning fork are at 90° (right angles) to the length of string.

$$\text{Frequency of vibration of string} = \text{frequency of tuning fork } n_T = \frac{p}{2l} \sqrt{\frac{T}{\mu}} = \frac{n_L}{2}$$

- In both the modes, Melde's law ($p^2T = \text{constant}$) is obeyed.

Characteristics of musical sound

- Musical sound has three characteristics. They are intensity or loudness, pitch or frequency and quality or timbre.
- (i) Intensity is objective term. It means power per unit area. It is expressed as watt/m². Phon also represents the unit of intensity of sound.
- (ii) Loudness is the subjective term. Intensity of sound as perceived by human ears is loudness. Loudness is measured in decibel (dB).
- (iii) Intensity (I) and loudness (L) are related by Weber's law as follows.
 $L = K \log I = \log(I/I_0)$ where I_0 denotes the threshold intensity *i.e.* the minimum intensity that can just be heard.
- (iv) Response of ear to loudness is logarithmic.
- (v) Intensity can be physically measured but loudness can only be felt by human ear. Loudness cannot be measured physically.
- (i) **Frequency** is defined as number of waves produced per second. Its unit is hertz or vib/sec.
- (ii) **Pitch:** It is the effect of frequency upon human ear. Pitch is thus subjective while frequency is objective. It cannot be measured physically. A shrill and sharp sound has higher pitch. A grave and dull sound has lower pitch.
- (iii) Pitch is directly dependent on frequency.
- (iv) Pitch is inversely dependent on intensity of sound. Lower the intensity, higher will be the pitch as in case of a humming mosquito.
 Higher the intensity, lower will be the pitch as in case of roar of a lion.
- **Quality or timbre**
 - (i) It is the characteristic of sound that differentiates between two sounds of same intensity and same frequency. Thus musical sounds of sitar and piano are determined by the quality of the sound of source.
 - (ii) Quality depends on harmonics/overtones produced and their relative order and intensity. Greater the number of harmonics present in a given sound sweeter will be the sound. Sound of flute is sweeter than sound of whistle.

Doppler's effect

- When a source of sound, or a listener, or both are in motion relative to one another, there is an apparent change in the frequency of sound, as heard by the listener. This phenomenon is called **Doppler effect**.
- It is observed that the frequency of the sound appears to be increased, when the source of the sound and the observer are approaching each other, but sound appears to be decreased when the two move away from each other.
- If n' = apparent frequency of sound as heard by the observer/listener
 n = actual frequency of sound emitted by source
 w = velocity of wind along (SO)
 v_s = velocity of source along (SO)
 v_o = velocity of observer along (SO)
 v = velocity of sound in air

then $n' = n \frac{(v + w) - v_o}{(v + w) - v_s}$

Note that any velocity along (SO) is positive and velocity along (OS) is negative.

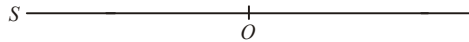

- When observer is at rest and source is in motion, $n' = \frac{nv}{v - v_s}$ assuming wind velocity to be zero.
Here source is approaching stationary observer.
- When source recedes away from stationary observer, $n' = \frac{nv}{v + v_s}$
- When observer approaches stationary source, $n' = \frac{n \cdot (v + v_o)}{v}$
- When observer recedes away from stationary source, $n' = \frac{n \cdot (v - v_o)}{v}$
- When a source revolves around a stationary observer, $n_{\max} = n \cdot \frac{v}{v - v_s}$; $n_{\min} = \frac{nv}{v + v_s}$

Beat frequency = $n_{\max} - n_{\min}$

- When an observer revolves around a stationary source,

$n_{\max} = \frac{n(v + v_o)}{v}$; $n_{\min} = \frac{n(v - v_o)}{v}$

Beat frequency = $n_{\max} - n_{\min}$.

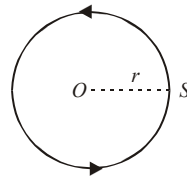

- Source moves towards stationary observer such that the pitch appears doubled.

$n' = n \left(\frac{v}{v - v_s} \right)$. Given $n' = 2n$

$2n = n \left(\frac{v}{v - v_s} \right) \Rightarrow 2(v - v_s) = v \Rightarrow v_s = \frac{v}{2}$.

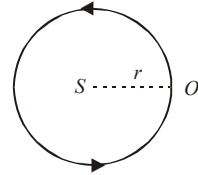

- Source recedes away from stationary observer such that the apparent frequency becomes half.

$$n' = n \left(\frac{v}{v + v_s} \right). \text{ Given } n' = \frac{n}{2}$$

$$\frac{n}{2} = n \left(\frac{v}{v + v_s} \right) \Rightarrow 2v = v + v_s \Rightarrow v_s = v.$$

- Observer approaches stationary source such that pitch is doubled.

$$n' = \frac{n(v + v_o)}{v}, \text{ Given } n' = 2n$$

$$2n = n \left(\frac{v + v_o}{v} \right) \Rightarrow 2v = v + v_o \Rightarrow v_o = v.$$

- Observer approaches stationary source such that the pitch is halved.

$$n' = \frac{n(v - v_o)}{v}, \text{ given } n' = \frac{n}{2}$$

$$\frac{n}{2} = n \left(\frac{v - v_o}{v} \right) \Rightarrow v = 2v - 2v_o \Rightarrow v_o = \frac{v}{2}.$$

- **Limitation/failure of Doppler's effect**

- (i) For supersonic speeds of source or observer, v_s and v_o should be less than v . $v_s < v$, $v_o < v$.
- (ii) There should be a relative motion between source and observer for Doppler's effect to apply.
- (iii) This effect fails when source and observer move at right angles to each other.

Some salient features about waves and sound

- The weakest audible sound has an intensity = 10^{-12} Wm^{-2} whose loudness is equal to 1 decibel.
- On moon, there is no atmosphere. Therefore sound cannot travel and so cannot be heard.
- Propagation constant of wave motion = $k = \frac{\omega}{v} = \frac{2\pi}{\lambda}$.
- Group velocity (v_g) = $d\omega/dk$.
- Order of loudness for whisper = 15 dB and for common conversation = 80-140 dB.
- Supersonic speed means speed is greater than the speed of sound in air *i.e.* greater than 332 m/s.
- Velocity of sound in solids is greatest and in gases the least.
- Intensity of waves $I = 2\pi^2 n^2 a^2 \rho v$ where n is frequency of wave, v is velocity of wave, a is amplitude of particle executing simple harmonic motion and ρ is density of medium. Loudness is effect of intensity on ear.
- If P is power of a sound source then intensity follows inverse square law of distance (d).

$$I = \frac{P}{4\pi d^2}.$$

- If source of sound is linear, then at a distance d from the line source, $I = \frac{P}{2\pi ld}$.
- In a homogeneous medium, velocity of wave in all directions and at all times is same.
- Wave velocity is constant and wave acceleration is zero.
- Particle velocity changes with time and particle acceleration is not zero.
- Doppler's effect fails for supersonic speeds of source or observer.
- Doppler' effect holds good for optical waves also.
- Open pipes contain all harmonics.
- Closed pipes contain only odd harmonics.

A decorative flourish above the word "End" written in a cursive script.

heat and thermodynamics

- Temperature and pressure are macroscopic properties of gases. These properties are related to molecular motion, which is a microscopic phenomenon. The theory which correlates between macroscopic properties and microscopic phenomena is called **kinetic theory of gases**. Kinetic means motion, and in this case motion of gas molecules.
- The individual molecules possess the standard physical properties of mass, momentum and energy. The density of a gas is simply the sum of the mass of the molecules divided by the volume which the gas occupies.
- As the gas molecules collide with the walls of a container, the molecules impact momentum to the walls, producing a force that can be measured. The force divided by the area is defined to be the **pressure**.
- The **temperature** of a gas is a measure of the mean kinetic energy of the gas. The molecules are in constant random motion and there is an energy associated with that motion. The higher the temperature, the greater will be the motion.
- In a solid, the location of the molecules relative to each other remains almost constant. But in a gas, the molecules can move around and interact with each other and with their surroundings in different ways, *i.e.* the molecules of gases are in constant random motion and frequently collide with each other and with the walls of the container in which it is placed.
- When the space for expansion of a gas is very large the molecules are far apart and thus, their mutual attraction is almost negligible and rarely collide with each other. Such a state of gas is called **perfect or ideal gas**.
- On the other hand, if the space available for expansion of a gas is comparatively small, the molecules are closer and are under the influence of their mutual interaction, they collide with each other freely. Such a state of gas is called the **real gas**.
- The properties of the gases have been studied experimentally and these experiments yielded three important gas laws. These gas laws are the study of the relationship between any two of the physical quantities (pressure, temperature and volume) specifying the state of gas, when the third is kept constant.
- **Boyle's law** : In 1662, the Irish scientist Robert Boyle discovered a basic law of gases that at a constant temperature, the volume and the pressure of a given mass of a gas are inversely proportional.

$$P = \frac{K}{V} \quad \text{or} \quad PV = K. \quad (\text{a constant})$$

This relationship is known as Boyle's law. K is a constant of proportionality.

- **Charles' law** : This law was discovered by A.C. Charles in 1787. According to this law, at constant pressure, the volume of a given mass of a gas is directly proportional to its absolute temperature.

$$V \propto T \text{ or } \frac{V}{T} = K \text{ (a constant)}$$

- **N.B.** - This constant K should not be confused with Kelvin temperature or thermal conductivity. It is a constant of proportionality.
- **Law of pressure** : At constant volume, the pressure of a given mass of a gas is directly proportional to its absolute temperature. This is called law of pressure.
- According to **Avogadro's law** under the same condition of pressure and temperature equal volume of different gases contain the same number of molecules.
- **Perfect gas equation** : Experimental study of gases show that there exists a relation between the pressure, volume and temperature of a given mass of a gas. This relation is called gas equation.

$$PV = nRT$$

where, P is pressure, V is volume, T is temperature, n the number of moles of gas and R the ideal gas constant.

- In SI, units of pressure, volume and temperature are Nm^{-2} , m^3 and K respectively.

Therefore units of gas constant R will be $R = \frac{PV}{nT} = \frac{\text{Nm}^{-2} \times \text{m}^3}{\text{no. of moles} \times \text{K}} = \frac{\text{JK}^{-1}}{\text{no. of moles}}$
i.e. unit of R = joule/mole-K.

- $R = 8.315 \text{ J/mol K}$ is called universal gas constant.
- $k_B = R/N_A = 1.38 \times 10^{-28} \text{ J/K}$ is called Boltzmann constant.
- The properties of gases can be explained on the basis of the kinetic model of gases. According to this model, a gas is a collection of a large number of molecules which are identical and are in a state of continuous rapid motion.
- **Claussius** and **Maxwell** developed the kinetic theory of gases in order to explain gas laws in terms of the motion of the gas molecules. The theory is based on the following assumptions.
 - (a) The number of molecules in the gas is large and the average separation between them is large compared with their dimensions.
 - (b) The molecules obey Newton's law of motion, but as a whole they move randomly.
 - (c) The molecules interact only by short range forces during elastic collisions.
 - (d) All the collisions between molecules among themselves or between molecules and the walls are elastic.
 - (e) The gas under consideration is a pure substance, that is, all molecules are identical.
 - (f) The duration of a collision is negligible compared to the time spent by the molecules between collisions.
 - (f) The molecules exert no force on each other or on the walls of the container except during collision.

- On the basis of **kinetic theory of gases**, the pressure exerted by an ideal gas on the walls of a container is given by

$$P = \frac{1}{3} \rho \bar{v}^2 \quad \dots \text{(i)}$$

where ρ is the density of the gas and \bar{v}^2 is mean square velocity of the molecules of the gas.

- The **root mean square velocity** of the molecules of the gas,

$$v_{\text{rms}} = \sqrt{\frac{3P}{\rho}} \quad \dots \text{(ii)}$$

If there be N number of molecules, each having mass m , in a V volume of gas, then from (i)

$$P = \frac{1}{3} \frac{mN}{V} \bar{v}^2$$

$$\text{or, } PV = \frac{1}{3} mN \bar{v}^2 = \frac{2}{3} \times \frac{1}{2} mN \bar{v}^2, \quad PV = \frac{2}{3} \times \text{kinetic energy.}$$

$$\text{where kinetic energy} = \frac{1}{2} mN \bar{v}^2$$

- Temperature of a gas, $T = \frac{2}{3k_B} \left(\frac{1}{2} m \bar{v}^2 \right)$.
- Temperature of gas is a direct measure of average translational molecular kinetic energy.
- The square root of \bar{v}^2 is called the root-mean square speed (rms) of the molecules.

$$v_{\text{rms}} = \sqrt{3RT/M} = \sqrt{\frac{3k_B T}{m}}$$

where M is the molar mass in kilogram per mole.

- The average speed of molecules $\bar{v} = \sqrt{\frac{8k_B T}{\pi m}} = \sqrt{\frac{8RT}{\pi M}}$
- The most probable speed, $v_{\text{mp}} = \sqrt{\frac{2k_B T}{m}} = \sqrt{\frac{2RT}{M}}$.
- $v_{\text{rms}} > \bar{v} > v_{\text{mp}}$.
- Maxwell, on purely statistical considerations, showed that the distribution of molecular speeds in a gas takes place according to a definite law. This is known as Maxwell's law of distribution of molecular speeds.
- Maxwell's law of speed distribution in a gas at temperature T is

$$n(v)dv = 4\pi n a^3 e^{-bv^2} v^2 dv$$

$$a = \sqrt{\frac{m}{2\pi k_B T}}, \quad b = \frac{m}{2k_B T}$$

where N is the total number of molecules and $n(v)$ stands for the number of molecules between speed v and $v + dv$. The $n(v)$ versus v plot is the Maxwell's speed distribution.

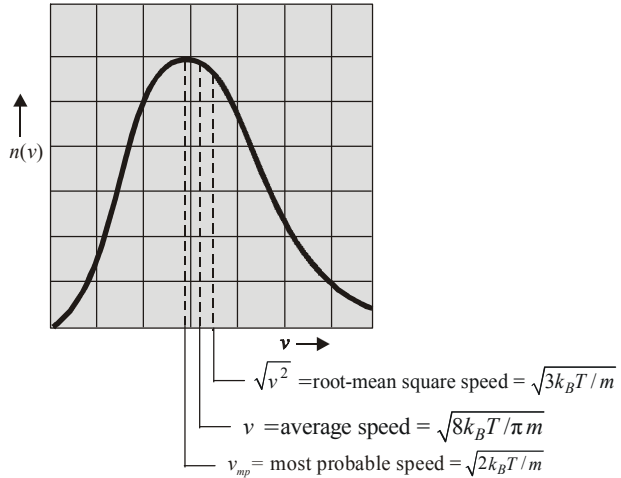

- **Degree of freedom** : The degree of freedom of a dynamic system implies the total number of independent coordinates required to specify the dynamic position of a particle or number of independent motions possible in it. A body having translational motion only has three degrees of freedom. A body which has rotational motion in addition to its translational motion will have six degrees of freedom - three for translational and three for rotational motion.
- According to theorem of **equipartition of energy**, the energy of a system in thermal equilibrium is equally divided among all degrees of freedom.
- Each degree of freedom contributes the same amount of average energy to the total, $\frac{1}{2}k_B T$ per molecule.
- Total translational kinetic energy of N molecules of gas,

$$E_{\text{total}} = N\left(\frac{1}{2}m\bar{v}^2\right) = \frac{3}{2}Nk_B T = \frac{3}{2}nRT$$
 where n is number of mole of a gas.
- Internal energy of a monoatomic gas is $U = \frac{3}{2}nRT$.
- Internal energy of a diatomic gas is $U = \frac{5}{2}nRT$.
- **Real gases**: Deviate at least slightly from ideal gas law because of two factors.
 1. Gas molecules attract one another.
 2. Gas molecules occupy a finite volume.

Both of these factors are neglected in the ideal gas law. Both increase in importance when molecules are close together (high P , low T).

- The real gases obey the **van der Waal's equation** instead of ideal gas equation.

$$\left(P + \frac{n^2 a}{V^2}\right)(V - nb) = nRT$$

where $\frac{n^2 a}{V^2}$ corrects for the attraction between molecules.

nb corrects for the volume of gas molecules.

a and b are called van der Waal's constants.

- When a gas is in the state of inequilibrium then the mass, energy and linear momentum of the particle of the gas are transferred from one place to another. This transfer is known as transport phenomenon.
- Diffusion phenomenon take place in the gases due to transport of mass.
- Viscosity is due to the transport of linear momentum between different layers of the gas.
- Heat conduction take place due to the transport of energy in the gases.
- The **mean free path** is the average distance travelled by a molecule between two successive collisions.
- If n is the number of molecules per unit volume of the gas and d is molecular diameter, then the mean free path is given by

$$\lambda = \frac{1}{\sqrt{2}\pi d^2 n}$$

- For air molecules at sea level, $\lambda \approx 10^{-7}$ m or 0.1 μ m. At an altitude of 100 km, the density of air has dropped to such an extent that $\lambda \approx 16$ cm.
- In 1827, Robert Brown discovered that fine pollen grains suspended in water were in a state of constant movement, describing small irregular paths but never stopping. This effect is called **Brownian motion**.
- Brownian motion is observed with many kind of small particles suspended in both liquids and gases.
- Brownian motion is due to the unequal bombardment of the suspended particles by the molecules of the surrounding medium.
- **The Celsius (or centigrade) temperature scale**
To define the Celsius temperature scale two "reliable" temperatures are used. These are, the melting point of pure ice, which gives us the lower fixed point of the scale and the boiling point of pure water (at atmospheric pressure) which gives us the upper fixed point. The difference between these two points is divided into 100 equal intervals called degrees.
- This chosen scale is a purely arbitrary scale.
- The Kelvin or absolute scale of temperature is a more fundamental scale.
- The size of the degree on the Kelvin scale is the same as on the Celsius scale but the zero corresponds to a very different temperature. To convert temperatures on the Celsius scale to temperatures on the Kelvin scale simply add 273 to the Celsius reading.
- **Absolute zero** is that temperature at which the volume of the gas becomes zero if pressure is a constant. The value of absolute zero is -273.15°C .

- **Thermal expansion**

Let coefficient of linear expansion = α

\therefore Coefficient of superficial expansion = $\beta = 2\alpha$

Coefficient of cubical expansion = $\gamma = 3\alpha$

- **Principle of calorimetry** : Whenever two bodies at different temperatures are mixed, heat lost by the body at higher temperature is gained by the body at lower temperature.
- Heat lost = heat gained
- If temperature of body changes but state of the body does not change, specific heat of the material of body is relevant whether heat is lost or gained.
Amount of heat lost or gained = $ms\theta$
where θ denotes change of temperature and m denotes mass of the body of specific heat s .
- If state of body changes (from solid to liquid or liquid to solid or liquid to gas or gas to liquid) but temperature of body does not change, amount of heat exchanged = mL where L = latent heat of the material which undergoes change of state.
- If change of temperature as well as change of state both occurs in a system, amount of heat exchanged = $ms\theta + mL$.
Conversion of ice at 0 K into steam at 100 K is an example of such a change.
- **The heat capacity of a body**
The larger pan of water needs a greater quantity of energy to cause its temperature to change by a given amount. We say that the larger pan has a greater heat capacity than the smaller one.
- The heat capacity of a body is the quantity of energy needed to cause its temperature to change by 1°C.
- The units of heat capacity are $\text{J}^\circ\text{C}^{-1}$ or JK^{-1}
- The heat capacity of a body depends on
 - what substance(s) it is made of and
 - the masses of the different substances in the body.
- The **specific heat capacity** of a substance is the quantity of energy needed to change the temperature of 1 kg of the substance by 1°C.
- The units of specific heat capacity are $\text{Jkg}^{-1}\text{C}^{-1}$ or $\text{Jkg}^{-1}\text{K}^{-1}$.
- To calculate the quantity of energy, Q , needed to change the temperature of m kg of a substance of specific heat capacity, s , by $\Delta T^\circ\text{C}$ we use the equation $Q = ms\Delta T$.
- To change the temperature of a body means to change the average kinetic energy of its particles.
- The particles of different substances have different masses. The number of particles in 1 kg of a substance depends on the mass of those particles. This explains why different substances have different specific heat capacities.
- The specific heat capacity of water is high compared with most other substances:
 $s_{\text{water}} = 4200 \text{ Jkg}^{-1}\text{C}^{-1}$ (approximately).
- Gases are said to have two principal specific (or molar) heat capacities:
 - the specific (or molar) heat capacity at constant volume, C_V
 - the specific (or molar) heat capacity at constant pressure, C_P
- It should be clear that $C_P > C_V$ and that the difference between them is given by
 $C_P - C_V = R$,
where R is the gas constant.

- The workdone by force is $W = Fs = PA_s$
But A_s is the change in the volume occupied by the gas, ΔV . Therefore $W = P\Delta V$.
- When the volume of a gas increases, work is done by the gas.
- When the volume of a gas decreases, work is done on the gas by an external force.
- However, if the temperature is increased and the gas is allowed to expand, work will be done. In this case, extra energy will have to be supplied to do this work.
- A "***P-V diagram***" is a graph showing changes in the pressure and volume of a sample of gas. It is useful to be able to recognise various types of change of the state of a gas from a *P-V* diagram.

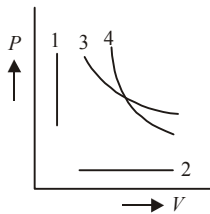

Four examples are given below.

1. Change of P (and T) at constant volume; an isovolumetric or isochoric change.
 2. Change of V (and T) at constant pressure; an isobaric change.
 3. Change in P and V at constant temperature; an isothermal change.
 4. Change in P and V in an insulated container (no heating of the gas); an adiabatic change.
- In practice, changes of state do not quite follow any of these ideal paths. However, approximate isothermal, adiabatic etc changes can occur.
 - For an isovolumetric change, heat the gas in a fixed volume container (one made of a material having a low thermal expansivity)
 - For an isobaric change, trap a small quantity of the gas in a tube using a thread of mercury (or other liquid, as in experiment 6TP) and heat it slowly
 - For an isothermal change, compress (or expand) the gas slowly in a container of high thermal conductivity.
 - For an adiabatic change, compress (or expand) the gas rapidly in a container of low thermal conductivity.
 - In case of isothermal relation between P and V for perfect gas is $PV = \text{constant}$.
 - In case of adiabatic relation between P and V for perfect gas is $PV^\gamma = \text{constant}$, where $\gamma = C_p/C_v$.
 - Slopes of isothermal and adiabatic curves are

$$\Rightarrow \frac{dP}{dV} = -\frac{P}{V} \quad (\text{for isothermal})$$

$$\Rightarrow \frac{dP}{dV} = -\frac{\gamma P}{V} \quad (\text{for adiabatic})$$

As $\gamma > 1$, therefore adiabatic curve at any point is steeper than the isothermal curve at that point.

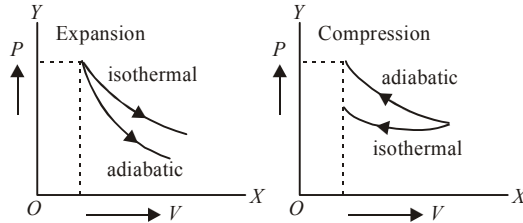

- Workdone in an isothermal expansion is

$$W = RT \ln \frac{V_2}{V_1} \quad \text{or} \quad W = RT \ln \frac{P_1}{P_2}.$$

- Workdone in an adiabatic expansion is

$$W = \frac{1}{(1-\gamma)} [P_2 V_2 - P_1 V_1] \quad \text{or,} \quad W = \frac{R(T_2 - T_1)}{(1-\gamma)}.$$

- Internal energy (U) of a system is the energy possessed by the system due to molecular motion and molecular configuration.
- According to **first law of thermodynamics**, heat given to a system (ΔQ) is equal to the sum of increase in its internal energy (ΔU) and the workdone (ΔW) by the system against the surroundings is

$$\Delta Q = \Delta U + \Delta W$$

- In cyclic process, $U_f = U_i$, $\Delta U = 0$.
 $\Rightarrow \Delta Q = 0 + \Delta W$, *i.e.* heat supplied is equal to workdone.
- In isothermal process, the temperature remains constant and if the system is an ideal gas, the internal energy $U (\propto T)$ will also remain constant. *i.e.* $\Delta U = 0$.
 $\therefore \Delta Q = \Delta W$.
i.e. heat supplied in an isothermal change is used to do work against external surroundings.
- In adiabatic process, no heat enters or leaves the system. *i.e.* $\Delta Q = 0$.
 $\Rightarrow 0 = \Delta U + \Delta W$ or, $\Delta U = -\Delta W$.
i.e. if gas expands (ΔW is +ve), internal energy and hence temperature will decrease and so the gas will get cooled.
- A "heat engine" is a machine which converts internal energy (from a high temperature body) into some other form of energy.
- The conversion of energy from some other form of energy to internal energy of a substance can be done with 100% efficiency of conversion. For example, 100 J of electrical energy will be converted to 100 J of internal energy by a resistor. Conversion of energy from internal energy to some other form cannot be done with the same efficiency.
- One statement of second law of thermodynamics "no heat engine, operating in a continuous cycle, can do work without transferring some internal energy from a hot body to a cold body."
- The hot body is called the heat source and the cold body (often the surroundings) is called the heat sink.

- Heat engines are often represented by diagrams like the figure given.

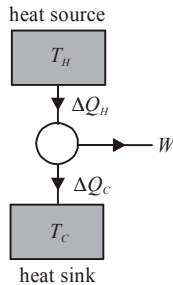

During each cycle:

W is the net work done by the engine.

ΔQ_H is the energy taken from the (hot) source.

ΔQ_C is the energy given to the (cold) sink.

- The thermodynamic efficiency (or just efficiency), η , of the engine is defined to be

$$\eta = \frac{\text{net work done}}{\text{energy taken from source}}$$

This fraction is usually multiplied by 100 to give a % so, if the net work done is only equal to half of the energy taken from the source, the engine has an efficiency of $\eta = 50\%$.

- $W = \Delta Q_H - \Delta Q_C$ so, $\eta = \frac{\Delta Q_H - \Delta Q_C}{\Delta Q_H} = 1 - \frac{\Delta Q_C}{\Delta Q_H}$.
- Experiments show that η increases as the difference between T_H and T_C increases. It has been shown that the theoretical maximum efficiency of a heat engine is given by

$$\eta_{\max} = 1 - \frac{T_C}{T_H}$$

- For an engine operating at maximum efficiency

$$\frac{\Delta Q_C}{\Delta Q_H} = \frac{T_C}{T_H} \quad \text{or,} \quad \frac{\Delta Q_C}{T_C} = \frac{\Delta Q_H}{T_H}$$

In other words, for an engine operating at the theoretical maximum efficiency, the quantity $\Delta Q/T$ for the source will be equal in magnitude to the same quantity for the sink.

- Entropy is defined as $\Delta S = \Delta Q/T$, where ΔQ represents the quantity of energy entering or leaving the body and T represents the absolute (or Kelvin or thermodynamic) temperature at which the energy transfer takes place.
- At 0 K (absolute zero) the atoms of a substance are stationary. They form a well ordered arrangement. When energy flows into a body its atoms vibrate, they become a less well ordered arrangement.
- Energy entering a body increases disorder
- Energy leaving a body decreases disorder
- Boltzmann showed that changes in entropy of a body can be considered as a direct measure of changes in the disorder of the arrangement of the particles.

- When a hot body is brought into thermal contact with a cold body for a short time -
 - (i) Each body will experience a change in the entropy of its particles.
 - (ii) The hot body experiences a decrease in entropy (a negative change) of magnitude $\Delta S_1 = \Delta Q/T_1$.
 - (iii) The cold body experiences an increase in entropy (a positive change) of magnitude $\Delta S_2 = \Delta Q/T_2$.
 - (iv) The net change in entropy $\Delta S = \Delta S_1 + \Delta S_2$.
- An alternative statement for the second law of thermodynamics - The effect of naturally occurring processes is always to increase the total entropy (or disorder) of the universe.
- **Carnot's theorem** : The maximum efficiency of a heat engine depends only on the temperatures of source and sink and for given source and sink temperatures no heat engine can be more efficient than a reversible engine.
- **P-V diagram for the Carnot cycle** : The Carnot cycle can be represented on a graph of pressure against volume (a P-V diagram) as shown here.

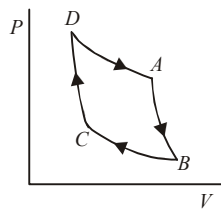

- D to A isothermal expansion at T_1 ; work done by the gas
- A to B adiabatic expansion ; work done by the gas
- B to C isothermal compression at T_2 ; work done on the gas
- C to D adiabatic compression ; work done on the gas
- The product of pressure and volume represents a quantity of work. This is represented by the area below a P-V curve.
- The area enclosed by the four curves represents the net work done by the engine during one cycle.
- **Coefficient of thermal conductivity**

$$(i) \quad \frac{dQ}{dt} = -K \cdot A \left(\frac{dT}{dx} \right)$$

where K = coefficient of thermal conductivity

A = area of the hotter face

$$\frac{dT}{dx} = \text{temperature gradient} = \frac{\theta \text{ (kelvin)}}{\text{metre}}$$

$$(ii) \quad \text{Units of } K \text{ are } \frac{\text{watt}}{\text{m} \times \theta} = \frac{\text{joule}}{\text{m} \times \text{s} \times \theta}$$

(iii) Dimensions of K are $[MLT^{-3}\theta^{-1}]$.

(iv) K denotes thermal conductivity, θ denotes dimensions of kelvin temperature.

• **Conducting slabs in series**

$$(i) \quad Q = \frac{A(T_1 - T_2)t}{\frac{x_1}{K_1} + \frac{x_2}{K_2} + \frac{x_3}{K_3}}$$

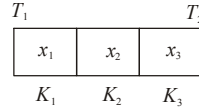

(ii) Consider two slabs when $x_1 = x_2 = x$

$$Q = \frac{A(T_1 - T_2)t}{\frac{x}{K_1} + \frac{x}{K_2}} = \frac{A(T_1 - T_2)t}{x(K_1 + K_2)}, \quad Q = \left(\frac{K_1 K_2}{K_1 + K_2} \right) \cdot \frac{A(T_1 - T_2)t}{x}$$

$$\text{Equivalent thermal capacity} = K = \frac{2K_1 K_2}{K_1 + K_2}$$

$$\frac{2}{K} = \frac{K_1 + K_2}{K_1 K_2} = \frac{1}{K_1} + \frac{1}{K_2}$$

K is harmonic mean between K_1 and K_2 .

(iii) For two slabs, in general, $K = \frac{K_1 K_2 (L_1 + L_2)}{L_1 K_2 + L_2 K_1}$.

• **Conducting slabs in parallel**

$$(i) \quad Q = K_1 A_1 \frac{(T_1 - T_2)t}{x} + K_2 A_2 \frac{(T_1 - T_2)t}{x} + \dots$$

$$Q = (K_1 A_1 + K_2 A_2 + \dots) \frac{(T_1 - T_2)t}{x}$$

(ii) Equivalent thermal capacity = K .

Let $A_1 = A_2 = A$

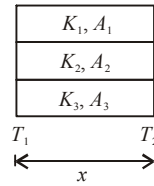

$$K = \frac{K_1 + K_2}{2} \text{ for two slabs. } K \text{ is arithmetic mean between } K_1 \text{ and } K_2.$$

(iii) Generally, for two slabs, $K = \frac{K_1 A_1 + K_2 A_2}{A_1 + A_2}$.

• **Thermal resistance**

$$(i) \quad R = \frac{\text{Temperature difference}}{\text{Rate of flow of heat}} = \frac{T_1 - T_2}{dQ/dt} = \frac{x}{KA}$$

Greater the K , smaller will be the thermal resistance.

$$(ii) \quad \text{Unit of } R = \frac{\text{kelvin}}{\text{watt}} = \frac{\text{kelvin} \times \text{sec}}{\text{joule}}$$

(iii) Dimensions of $R = [\text{ML}^2\text{T}^{-3}\theta^{-1}]^{-1}$

where θ = dimensions of kelvin temperature.

$$= [\text{M}^{-1}\text{L}^{-2}\text{T}^3\theta].$$

N.B. - K denotes thermal conductivity of material, θ denotes dimensions of kelvin temperature. θ is chosen to avoid confusion between conductivity-coefficient and kelvin temperature.

• **Thermal diffusivity/thermometric conductivity**

(i) This quantity is represented by h .

$$h = \frac{\text{thermal conductivity}}{\text{thermal capacity per unit volume.}}$$

$$h = \frac{K}{ms/V} = \frac{K}{\rho s} \text{ where}$$

ρ = density of material, s = specific heat of material

K = coefficient of thermal conductivity

(ii) Unit of $h = \frac{\text{watt} \times \text{kg} \times \theta}{\text{m} \times \theta \times \text{kgm}^{-3} \times \text{joule}} = \text{m}^2\text{s}^{-1}$.

(iii) Dimensions of $h = \frac{\text{dimensions of thermal conductivity}}{\text{dimensions of (density} \times \text{specific heat)}}$

$$[h] = \frac{\text{MLT}^{-3}\theta^{-1}}{\text{ML}^{-3} \times \text{L}^2\text{T}^{-2}\theta^{-1}} = [\text{L}^2\text{T}^{-1}]$$

$$[h] = [\text{L}^2\text{T}^{-1}].$$

• **Ingen Hausz experiment/apparatus**

Several rods are coated with wax.

K = thermal conductivity of material of rod.

l = length of rod upto which wax melts.

l^2/K = constant.

$$\frac{l_1^2}{K_1} = \frac{l_2^2}{K_2} = \frac{l_3^2}{K_3} = \frac{l_4^2}{K_4} \dots$$

• **Accretion/formation of ice on lakes**

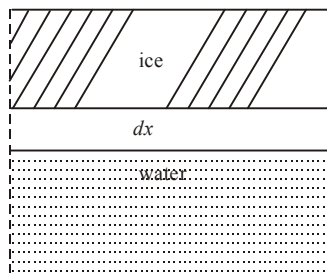

(i) t = time taken, x = thickness of ice formed

ρ = density of ice, L = latent heat of ice

K = coefficient of thermal conductivity

θ = temperature above lake

$$t = \frac{\rho L}{2K\theta} \cdot x^2$$

$$(ii) \quad t = \frac{\rho L}{2K\theta} (x_2^2 - x_1^2)$$

= time taken in increasing thickness of ice from x_1 to x_2 .

- **Process of heat conduction**

- (a) Molecules from higher temperature zone collide with molecules of lower temperature zone.
- (b) In metals, presence of free electrons contribute to conduction.
- (c) Silver is the best conductor while copper is the second best conductor of heat (also electricity).
- (d) Mercury is the only liquid which is a good conductor of heat.

- **Convection of heat**

- (a) During convection, medium moves to transfer heat on account of difference of densities between hotter and colder parts.
- (b) During convection, the temperature gradient exists in vertical direction and not in horizontal direction.
- (c) Liquids and gases are heated by convection.
- (d) Convection is of two types.:
 - (i) Forced or induced convection.
Newton's law of cooling is applicable.
 - (ii) For natural convection
Rate of cooling $\propto (\theta - \theta_0)^{5/2}$.
- (e) Gravity has a role to play in convection.
- (f) Speed of convection is greater than that of conduction but much less than that of radiation.
- (g) Most of the heat transfer on earth is by convection.
The contribution due to conduction and radiation is very small.

- **Radiation of heat**

It is the process in which transmission of heat occurs in the form of electromagnetic waves of wavelength from about 8000 \AA ($8 \times 10^{-7} \text{ m}$) to about 4 mm . Intervening medium is not required for radiation. Heat radiations are actually covered under infrared waves. In vacuum, the speed of radiation is $3 \times 10^8 \text{ m/s}$. This is equal to velocity of light or velocity of electromagnetic radiations.

Black body

- A black body absorbs all the radiations incident upon it. All wavelengths/frequencies are in fact, absorbed.
- A black body is a good absorber, good emitter, a bad reflector and a bad transmitter. Its absorptive coefficient is unity if the black body is ideal. In case of perfectly black body, coefficients of reflection and transmission are zero.
- When heated to a high temperature, an ideal black body emits radiations of all wavelengths/frequencies.
- An ideal black body need not be black in colour.

- The black body radiations are also known as white radiations because it emits all radiations when heated to a high temperature.
- The radiations from a black body depend upon its temperature only. These heat radiations do not depend on density, mass, size or the nature of the body.
- The emission spectrum of an ideal black body is a continuous spectrum. Hence all bodies in nature emitting continuous spectrum are black bodies. Sun or a lamp of high power are thus black bodies giving continuous spectrum.
- Lamp black is 96% black and platinum black is about 98% black.
- Wien's black body and Ferry's black body are considered to be almost black.
- A fine hole in a double walled spherical cavity, evacuated and painted black, represents Ferry's black body.

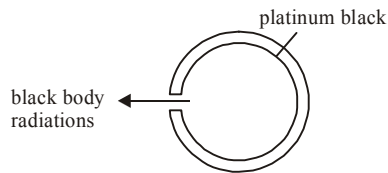

Stefan's law and Stefan-Boltzmann law

- Let Q = heat energy emitted by a body
 e = emissivity of material of body
 $e = 1$ for perfectly black body
 A = area which radiates energy
 t = time for which energy is radiated
 $Q = eAt \cdot (\sigma T^4)$ where T denotes absolute temperature.
- For perfectly black body, $e = 1$
 $Q = At(\sigma T^4)$.
- $\frac{Q}{At} = \sigma T^4$. Put $E = Q/At$
 $\therefore E = \sigma T^4$. This is Stefan's law.
 - (i) A black body at temperature T_2 is enclosed in a black body at temperature T_1 ($T_2 > T_1$), then
 Net $E = E_2 - E_1$
 Net $E = \sigma(T_2^4 - T_1^4) = \text{Stefan-Boltzmann law.}$
 - (ii) Total energy lost $Q = A \cdot t \cdot \sigma(T_2^4 - T_1^4)$
 - (iii) When the body and its enclosure are not perfectly black,
 Net $E = e\sigma(T_2^4 - T_1^4)$
 Net $Q = eAt\sigma(T_2^4 - T_1^4)$.

Thermal radiations

- For thermal radiations/infrared region of electromagnetic spectrum, λ is confined from 8000 \AA ($8 \times 10^{-7} \text{ m}$) to about 4 mm. Roughly speaking λ is between 10^{-6} to 10^{-2} m .
- Thermal radiations can be detected by Crook's radiation micrometer, Boy's radiomicrometer, Bolometer, Pyrometer, differential air thermometer and thermopile.
- Thermal radiations are emitted by every body whose temperature is greater than zero kelvin.

- Higher the temperature of body, greater will be the amount of radiations emitted and vice versa.
- When a body absorbs heat radiations, its temperature rises. The temperature falls when a body emits heat radiations.
- Thermal radiations exhibit all properties of electromagnetic radiations emitted by their wavelengths.
- Spectrum of infrared region is studied with the prism of Quartz or rock salt. Glass absorbs heat radiations and so prisms of glass are not used.
- **Energy flux**
 - (i) It is the energy flowing per second per unit area normal to any surface.
 - (ii) Its units are $\frac{\text{joule}}{\text{sec} \times \text{metre}^2} = \frac{\text{watt}}{\text{metre}^2}$
- **Energy density**
 - (i) It is the total energy per unit volume.
 - (ii) Its unit are joule/m³.
- Due to a point source of radiation,
 - (i) Intensity (I) $\propto \frac{1}{(\text{distance } d)^2} \propto (\text{amplitude } A)^2$
 - (ii) Amplitude $A \propto \frac{1}{\text{distance } d} \Rightarrow A \propto \frac{1}{d}$
- Due to linear source of radiation, $I \propto \frac{1}{d}$ and $A \propto \frac{1}{\sqrt{d}}$
- For normal radiations, radiation pressure exerted
 - (i) on perfectly absorbing surface is $P = \text{energy density}$
 - (ii) on perfectly reflecting surface is $P = 2 \times \text{energy density}$
 - (iii) Energy flux = velocity (c) \times energy density
- For inclined radiations,
 - (i) $P = \text{energy density}/3$, on perfect absorber
 - (ii) $P = \frac{2}{3} \times \text{energy density}$ on perfect reflector
 - (iii) Energy flux = velocity (c) $\times \frac{\text{energy density}}{4}$
- **Reflectance, absorptance and transmittance**
 - (i) Let in a given time t , amount of thermal radiation incident = Q ; reflected = Q_1 ; absorbed = Q_2 ; transmitted = Q_3
then $Q = Q_1 + Q_2 + Q_3$.
 - (ii) Let $r = \text{reflectance} = \text{reflecting power} = Q_1/Q$
 $a = \text{absorptance} = \text{absorbing power} = Q_2/Q$
 $t = \text{transmittance} = \text{transmitting power} = Q_3/Q$
 $r + a + t = \frac{Q_1 + Q_2 + Q_3}{Q} = \frac{Q}{Q} = 1$.

(iii) If $t = 0$, $r + a = 1 \Rightarrow a = 1 - r$.

This shows that good reflectors are bad absorbers and good absorbers are bad reflectors.

(iv) Similarly, good transmitters are bad absorbers and bad reflectors. Vice-versa is also true.

- **Prevost's theory of heat exchange**

(i) Every body emits heat radiations at all temperatures, except zero kelvin, as well as absorbs radiations incident upon it.

(ii) Temperature of a body rises if the energy absorbed is more than the energy emitted.

(iii) Temperature of a body falls if the energy emitted is more than the energy absorbed.

(iv) Temperature of a body remains constant when the energies absorbed and emitted are equal. Thermal equilibrium is reached in such a case.

(v) At absolute zero temperature (0 K or -273°C) there is no heat exchange among various bodies.

- **Kirchhoff's law**

(i) At a given temperature and for a given wavelength λ , for all bodies,

$$\frac{e_\lambda}{a_\lambda} = \text{constant} = E_\lambda$$

where e_λ = spectral emissive power

a_λ = monochromatic absorptive power

E_λ = emissive power of perfectly black body

(ii) $e_\lambda \propto a_\lambda$.

Hence good emitters are good absorbers also.

(iii) The various colours of bodies are explained on the basis of this law.

(iv) Fraunhofer lines are explained on the basis of this law.

(v) The law implies that, at a particular temperature, a body can absorb only those wavelengths which it is capable of emitting.

- **Colours - primary and complementary**

- Primary colours are those which do not get dispersed when passed through a prism.

- The primary colours are red, blue and green.

- Complementary colours are those two colours which when mixed produce white light.

- The colour triangle indicate these colours as below.

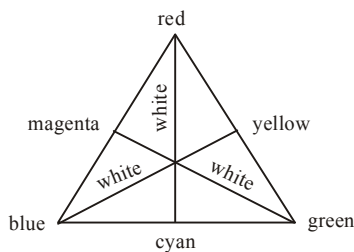

- Red + green = yellow

- Green + blue = cyan (turquoise)

- Blue + red = magenta (purplish red)
- Complementary colours : yellow + blue = white
magenta + green = white
cyan + red = white
- Red + yellow + blue = black
- When a green body is heated in a dark room then it appears red because it emits all colours except green and the emitted colours are dominated by red colour. It is also true vice-versa.
- **Fraunhofer lines** : These are the dark lines present in the continuous spectrum of Sun.
- These are due to absorption of radiations.
- Photosphere, the central part of Sun, is at a temperature of the order of 10^7 K. It emits continuous light of all wavelengths. These radiations pass through chromosphere which is at 6000 K. It contains certain elements in vapour form. These elements selectively absorb certain wavelengths. These missing wavelengths are dark Fraunhofer lines.
- About 20000 such dark lines have been detected so far.
- These dark lines belong to hydrogen, helium, sodium, iron, calcium etc.
- At the time of total solar eclipse, photosphere is covered by moon. The elements present in the chromosphere emit the characteristic wavelength they had absorbed. Therefore, Fraunhofer lines appear as bright lines at the time of total solar eclipse.
- Kirchhoff's law explains this phenomenon.
- These lines are not perfectly black but they appear dark, because of their lower intensity in comparison to remaining part of spectrum.
- These lines were named as *A, B, C, D ...* etc.
- **Variation of colour with temperature**
 - Light red colour at temperature 525°C
 - Cherry red colour at temperature 900°C
 - Orange red colour at temperature 1100°C
 - Yellow colour at temperature 1200°C
 - White colour at temperature 1600°C
 - Higher the temperature of the body, higher the frequency of colour or lower the wavelength of colour.
 - The white light intensity is concentrated in yellow-green region.
- **Wien's displacement law**
 - (i) According to this law, $\lambda_m = \frac{b}{T}$ where
 λ_m = wavelength corresponding to which the energy emitted per second per unit area by a perfectly black body is maximum
 T = absolute temperature of the black body
 b = Wien's constant
 $b = 2.898 \times 10^{-3} \approx 3 \times 10^{-3}$ mK.
- $\lambda_m = \frac{c}{\nu_m}$, where c denotes velocity, ν_m denotes frequency.

- As temperature increases, colour changes towards higher frequency side.
i.e. from orange \rightarrow yellow \rightarrow green \rightarrow blue \rightarrow violet
Temperature of violet star is maximum, temperature of red star is minimum. For Sun, $\lambda_m = 4753 \text{ \AA}$ (yellow colour) at temperature 6000 K. It is a medium category star.

- Newton's law of cooling**

- (i) According to this law, $-\frac{dQ}{dt} = K(\theta - \theta_0)$ where

$$\frac{dQ}{dt} = \text{rate of loss of heat of a liquid}$$

$(\theta - \theta_0)$ = difference in temperatures of liquid and the surrounding

K = constant of proportionality

- (ii) As $Q = ms\theta$ where m = mass, s = specific heat of liquid

$$\frac{dQ}{dt} = ms \frac{d\theta}{dt} = -K(\theta - \theta_0)$$

$$\Rightarrow -\frac{d\theta}{dt} = -\frac{K}{ms}(\theta - \theta_0)$$

Rate of fall of temperature = $d\theta/dt$

$$\text{Rate of cooling} = ms \frac{d\theta}{dt}$$

$$\text{Rate of loss of heat} = \text{rate of cooling} = m.s \frac{d\theta}{dt}$$

- Difference of temperature should be less than 30°C .
- It is covered under forced or induced convection.

Some salient points about transmission of heat

- When rates of cooling of two bodies are same, then the rate of fall of temperature of a body with highest heat capacity/thermal capacity will be the least.

$$-\frac{d\theta}{dt} \propto \frac{1}{ms} \propto \frac{1}{\text{thermal capacity}}$$

- If two liquids are cooled under identical conditions, rate of fall of temperature ($d\theta/dt$) of that liquid will be minimum whose specific heat is maximum and *vice-versa*.
- Less the specific heat, greater is the rate of cooling or heating.
- Water has highest specific heat among liquids. It heats or cools at a low rate.
- The effective area of a rough body is always greater than its geometrical area. On blackening the bottom of rough bodies, their absorptance or coefficient of absorption increases.
- Solar constant** : It is defined as the amount of energy received per minute per cm^2 of earth's surface held normally to Sun rays at mean distance of the earth from the Sun in the absence of atmosphere. $S \approx 1 \text{ kilowatt/m}^2$ or $S = \text{solar constant} = 1.937 \text{ cal cm}^{-2} \text{ min}^{-1}$.

- Heat radiations are electromagnetic in nature. They are transverse waves. Electrically they are neutral. They travel with velocity (c) = $3 \times 10^8 \text{ ms}^{-1}$.
Energy of heat radiations = $h\nu = hc/\lambda$, h = Planck's constant.
Momentum = h/λ , ν = frequency, λ = wavelength.
- The energy distribution in the black body spectrum is not uniform. Somewhere it is maximum and somewhere minimum.
- The value of radiation pressure of solar radiations = P
 $P = 7 \times 10^{-5} \text{ newton/metre}^2$.
- The formation of tail of a comet is the result of solar radiation pressure.
- The radiation pressure on bigger particles is less and on smaller particles is more.
- Molecular motion ceases and therefore heat exchange among various bodies ceases at absolute zero.

A decorative flourish above the word "End" written in a cursive script.

electrostatics

Charge

- **Quantization:** Charge is always in the form of an integral multiple of electronic charge and never its fraction.

$$q = \pm ne \text{ where } n \text{ is an integer and } e = 1.6 \times 10^{-19} \text{ coulomb} \\ = 1.6 \times 10^{-19} \text{ C.}$$

Charge on an electron/proton is the minimum charge.

- Particles, known as quarks, are predicted theoretically by Gell-mann. Quarks contain charges $\pm \frac{e}{2}$, $\pm \frac{e}{3}$, $\pm \frac{2e}{3}$.

Nobel prize of physics declared in 2004 refers to quarks.

- Millikan's oil drop experiment showed the discrete nature of charge. Charge cannot be fractional multiple of e . Quarks now throw a challenge.
- Charge on an electron is -ve. $e = -1.6 \times 10^{-19} \text{ C}$.
Charge on a proton is +ve. $e = +1.6 \times 10^{-19} \text{ C}$.
Total charge = $\pm ne$.
- A particle/body is positively charged because it loses electrons or it has shortage of electrons.
- A particle is negatively charged because it gains electrons or it has excess of electron.
- **Conservation:** The total net charge of an isolated physical system always remains constant. Charge can neither be created nor destroyed. It can be transferred from one body to another.

Coulomb's inverse square law

- $F = \frac{1}{4\pi\epsilon_0} \cdot \frac{q_1q_2}{r^2}$ where F denotes the force between two charges q_1 and q_2 separated by a distance r in free space. ϵ_0 is a constant known as permittivity of free space. Free space is vacuum and may be deemed to be air practically.

$$\frac{1}{4\pi\epsilon_0} = 9 \times 10^9 \frac{\text{newton-metre}^2}{\text{coulomb}^2} = 9 \times 10^9 \frac{\text{N-m}^2}{\text{C}^2}$$

- If free space is replaced by a medium, then ϵ_0 is replaced by (ϵ_0K) or $(\epsilon_0\epsilon_r)$ where K is known as **dielectric constant** or relative permittivity or specific inductive capacity (S.I.C.) or dielectric coefficient of the medium/material/matter. Thus

$$F = \frac{1}{4\pi\epsilon} \cdot \frac{q_1q_2}{r^2} = \frac{1}{4\pi\epsilon_0K} \cdot \frac{q_1q_2}{r^2} = \frac{1}{4\pi\epsilon_0\epsilon_r} \cdot \frac{q_1q_2}{r^2}.$$

- $K = \frac{\epsilon}{\epsilon_0}$ or $\epsilon_r = \frac{\epsilon}{\epsilon_0}$.
 $K = 1$ for vacuum (or air), $K = \infty$ for conductor/metal.
- $\epsilon_0 = 8.85 \times 10^{-12} \text{ C}^2 \text{ N}^{-1} \text{ m}^{-2}$.
- Vector form of the law (q_1 and q_2 are like charges)

$$(i) \quad \vec{F}_{12} = \frac{1}{4\pi\epsilon_0} \frac{q_1q_2}{r_{21}^3} \vec{r}_{21} = \frac{1}{4\pi\epsilon_0} \frac{q_1q_2}{|\vec{r}_1 - \vec{r}_2|^3} (\vec{r}_1 - \vec{r}_2)$$

$$(ii) \quad \vec{F}_{21} = \frac{1}{4\pi\epsilon_0} \frac{q_1q_2}{|\vec{r}_2 - \vec{r}_1|^3} (\vec{r}_2 - \vec{r}_1) = \frac{q_1q_2}{4\pi\epsilon_0} \frac{\vec{r}_{12}}{r_{12}^3}$$

- If \hat{r}_{12} is a unit vector pointing from q_1 to q_2 , then

$$(i) \quad \vec{F}_{12} = \frac{1}{4\pi\epsilon_0} \frac{q_1q_2}{r_{21}^2} \hat{r}_{21} = \text{force on } q_1 \text{ by } q_2.$$

When $q_1q_2 > 0$ for like charges.

$$(ii) \quad \vec{F}_{21} = \frac{1}{4\pi\epsilon_0} \frac{q_1q_2}{r_{12}^2} \hat{r}_{12} = \text{force on } q_2 \text{ by } q_1$$

When $q_1q_2 > 0$ for like charges .

Intensity/strength of electric field

- Intensity at a point is numerically equal to the force acting on a unit positive charge placed at the point.
- It is a vector quantity.
- The units of intensity E are NC^{-1} , volt/metre.
- The dimensions of E are $[\text{MLT}^{-3}\text{A}^{-1}]$.
- **Intensity due to a charge q at distance r**

$$(i) \quad E = \frac{1}{4\pi\epsilon_0} \cdot \frac{q}{r^2}.$$

It acts in the direction in which a +ve charge moves.

$$(ii) \quad E = \frac{1}{4\pi\epsilon_0K} \cdot \frac{q}{r^2}, \text{ if point is in the medium.}$$

- **Potential (V) and intensity (E)**

$$(i) \quad E = -\frac{dV}{dr} \text{ when potential varies with respect to distance.}$$

$$(ii) \quad E = \frac{\text{potential difference}}{\text{distance}} = \frac{V}{r} \text{ when potential difference is constant.}$$

(iii) Potential at a point distance r from charge q .

$$V = \frac{1}{4\pi\epsilon_0} \cdot \frac{q}{r} \text{ in free space}$$

(iv) $V = \frac{1}{4\pi\epsilon_0 K} \cdot \frac{q}{r}$ in medium

(v) Potential is a scalar quantity

$$\vec{E} \cdot d\vec{r} = dV$$

- From positively charged surface, \vec{E} acts outwards at right angles *i.e.* along outward drawn normal.
- Intensity is equal to flux (number of electric lines of force) crossing unit normal area.

$$\vec{E} = \frac{\text{flux } (\phi)}{\text{area } (\vec{s})}$$

Electric lines of force

- Electric lines of force start from positive charge and terminate on negative charge.
- From a positively charged conducting surface lines of force are normal to surface in outward direction.
- Electric lines of force about a negative point charge are radial, inwards and about a positive point charge are radial, outwards.
- Electric lines of force are always perpendicular to an equipotential surface.
- These lines of force contract along the length but expand at right angles to their length. There is longitudinal tension and lateral pressure in a line of force. Contraction shows attraction between opposite charges while expansion indicates that similar charges repel.
- The number of electric lines of force (flux) passing through unit normal area at any point indicate electric intensity at that point.
- For a charged sphere these lines are straight and directed along radius.
- These may be open or closed curves. They are not necessarily closed though the magnetic lines of force are closed.
- Two lines of force never intersect or cut each other.
- Lines of force are parallel and equally spaced in a uniform field.
- Tangent to the curve at a point shows direction of field.

Gauss law

- For a closed surface enclosing a net charge q , the net electric flux ϕ emerging out is given by

$$\phi = \oint_s \vec{E} \cdot d\vec{s} = \frac{q}{\epsilon_0}$$

- If a dipole is enclosed by a closed surface, flux ϕ is equal to zero. Here the algebraic sum of charges ($+q - q = 0$) is zero.
- The flux will come out if +ve charge is enclosed. The flux will enter if negative charge is enclosed.
- **Flux from a cube**
 - (i) If q is at the centre of cube, total flux (ϕ) = q/ϵ_0 .
 - (ii) From each face of cube, flux = $q/6\epsilon_0$.

- **Electric field due to a charged shell**

(i) At an external point, $E = \frac{Q}{4\pi\epsilon_0 r^2}$.

This is the same as the field due to a point charge placed at the centre.

(ii) At a point on surface of shell, this is E_{\max} .

$$E = \frac{Q}{4\pi\epsilon_0 R^2}$$

Again the shell behaves like a point charge placed at the centre.

(iii) At an inside point ($r' < R$), $E = 0$.

Thus a charge q placed inside a charged shell does not experience any force due to the shell.

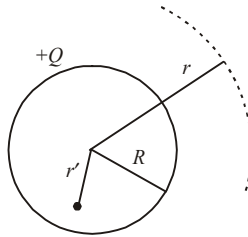

- **Gaussian surface**

- For a sphere or spherical shell - a concentric sphere.
- For a cylinder or an infinite rod - a coaxial cylinder.
- For a plate - a cube or a cuboid.

Potential and intensity due to a charged conducting sphere (or shell)

- **At a point outside the charged sphere**

(i) Intensity $E = \frac{1}{4\pi\epsilon_0} \cdot \frac{q}{r^2}$ ($r >$ radius of sphere R)

It is a vector quantity.

(ii) Potential $V = \frac{1}{4\pi\epsilon_0} \cdot \frac{q}{r}$

It is a scalar quantity.

- **At a point on the surface of charged sphere**

(i) Intensity $E = \frac{1}{4\pi\epsilon_0} \cdot \frac{q}{R^2}$ ($r =$ radius of sphere R)

Intensity is a vector quantity.

(ii) Potential $V = \frac{1}{4\pi\epsilon_0} \cdot \frac{q}{R}$

Potential is a scalar quantity.

- **At a point inside the sphere ($r <$ radius of sphere)**

(i) Intensity $E =$ zero.

(ii) Potential $V = \frac{1}{4\pi\epsilon_0} \cdot \frac{q}{R}$

Potential is constant inside the sphere. This is same as potential at the surface of sphere.

- **At the centre of sphere**

- (i) Intensity $E = \text{zero}$.
- (ii) Potential $V = \frac{1}{4\pi\epsilon_0} \cdot \frac{q}{R}$

- **At infinity**

- (i) Intensity $E = \text{zero}$.
- (ii) Potential $V = \text{zero}$.

Electric field and potential due to charged non-conducting sphere

- **Outside the sphere when $r >$ radius of sphere R**

- (i) Electric intensity $E = \frac{1}{4\pi\epsilon_0} \cdot \frac{q}{r^2}$. It is a vector quantity.
- (ii) Electric potential $V = \frac{1}{4\pi\epsilon_0} \cdot \frac{q}{r}$. It is a scalar quantity.

- **On the surface of the sphere where $r = R$**

- (i) Electric intensity $E = \frac{1}{4\pi\epsilon_0} \cdot \frac{q}{R^2}$. Intensity is a vector quantity.
- (ii) Electric potential $V = \frac{1}{4\pi\epsilon_0} \cdot \frac{q}{R}$. Potential is a scalar quantity.

- **Inside the sphere when $r < R$**

- (i) Electric intensity $E = \frac{1}{4\pi\epsilon_0} \cdot \frac{qr}{R^3}$. Vectorially, $\vec{E} = \frac{1}{4\pi\epsilon_0} \cdot \frac{q}{R^3} \vec{r}$
- (ii) Electric potential $V = \frac{1}{4\pi\epsilon_0} \cdot \frac{q(3R^2 - r^2)}{2R^3}$

- **At the centre of sphere when $r = 0$**

- (i) Electric intensity $E = \text{zero}$.
- (ii) Electric potential $V = \frac{3}{2} \frac{1}{4\pi\epsilon_0} \cdot \frac{q}{R}$

\therefore Potential at centre = $\frac{3}{2} \times$ potential at surface

- **At infinity**

- (i) Intensity = zero.
- (ii) Potential = zero.

Electric dipole

- Two equal and opposite charges (q) each, separated by a small distance (l) constitute an electric dipole. Many of the atoms/molecules are dipoles.

- (i) Dipole moment $\vec{p} = q \times (\vec{l})$
- (ii) Dipole moment is a vector quantity.
- (iii) The direction of \vec{p} is from negative charge to positive charge.

- (iv) Unit of dipole moment = coulomb-metre = Cm.
 (v) Dimension of dipole moment = [ATL].

• **Intensity of electric field due to a dipole**

- (i) Along axis at distance r from centre of dipole

$$E = \frac{2p}{r^3} \cdot \frac{1}{4\pi\epsilon_0}$$

Direction of E is along the direction of dipole moment.

- (ii) Along equator of dipole at distance r from centre

$$E = \frac{p}{r^3} \cdot \frac{1}{4\pi\epsilon_0}$$

Direction of E is antiparallel to direction of p .

- (iii) At any point along direction θ

$$E = \frac{p}{r^3} \sqrt{1 + 3\cos^2\theta} \cdot \frac{1}{4\pi\epsilon_0}$$

The direction of E makes an angle β with the line joining the point with centre of dipole where $\tan\beta = \frac{1}{2} \tan\theta$.

• **Torque on a dipole**

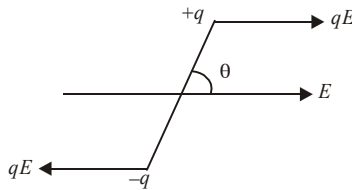

- Two forces [qE and $(-qE)$] equal, opposite and parallel, separated by a distance constitute a couple.

$$\text{torque } (\vec{\tau}) = \vec{p} \times \vec{E}$$

$$|\vec{\tau}| = pE \sin\theta$$

This direction of $\vec{\tau}$ is perpendicular to the plane containing \vec{p} and \vec{E} . The torque tends to align the dipole in the direction of field.

- When dipole is parallel to electric field, it is in stable equilibrium. When it is antiparallel to electric field, it is in unstable equilibrium.
 • Torque is maximum when $\theta = 90^\circ$. Dipole is perpendicular to E . Therefore maximum torque = pE .

Potential energy of dipole in uniform electric field

- Workdone in rotating the dipole from an angle θ_1 to angle θ_2 .

$$W = \int_{\theta_1}^{\theta_2} \tau d\theta = \int_{\theta_1}^{\theta_2} pE \sin\theta d\theta$$

$$= pE [-\cos\theta]_{\theta_1}^{\theta_2} = -pE(\cos\theta_2 - \cos\theta_1)$$

- (i) If $\theta_1 = 0$ and $\theta_2 = 180^\circ$, $W = 2pE$.
- (ii) if $\theta_1 = 0$ and $\theta_2 = 90^\circ$, $W = pE$.
- Potential energy of dipole, when it is turned through an angle θ from field direction is

$$U = -pE\cos\theta = -\vec{p} \cdot \vec{E}$$
 - (i) If $\theta = 0$, $U = -pE$.
The dipole orients itself parallel to field.
 - (ii) If $\theta = 90^\circ$, $U = 0$.
 - (iii) If $\theta = 180^\circ$, $U = pE$.
- Variation of potential energy of dipole with angle θ , between \vec{E} and \vec{p} , is shown in the figure.
 - (i) Potential energy is negative from 0 to $\pi/2$ and $3\pi/2$ to 2π . They are regions of stable equilibrium of dipole.
 - (ii) Potential energy is positive from $\pi/2$ to $3\pi/2$. This is the region of unstable equilibrium of the dipole.

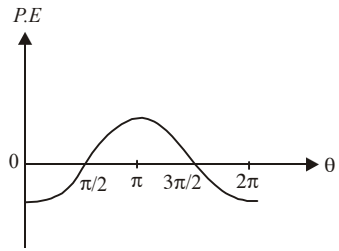

Dipole in non-uniform electric field

- In non-uniform electric field, the two ends of dipole are acted upon by forces qE_1 and $-qE_2$. They are not equal as $E_1 \neq E_2$ in non-uniform field. Hence a force and a torque both act on the dipole.
- Force acting on the dipole can be represented by $\vec{F} = \vec{p} \times \frac{d\vec{E}}{dr}$

Broadly speaking,

Net force = $(qE_1 - qE_2)$ along direction of greater field intensity.

- On account of net force upon dipole, it may undergo linear motion.
- In a non-uniform electric field, a dipole may, therefore, undergo rotation as well as linear motion.

Potential energy of charge system

- For two point charges q_1 and q_2 separated by a distance r , electrostatic potential energy U is given by

$$U = \frac{1}{4\pi\epsilon_0} \cdot \frac{q_1q_2}{r}$$

- For three point charges, $U = \frac{1}{4\pi\epsilon_0} \cdot \left[\frac{q_1q_2}{r_1} + \frac{q_2q_3}{r_2} + \frac{q_3q_1}{r_3} \right]$

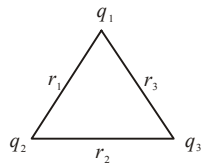

- For n charges, consider all pairs with due regard of signs of charges, positive or negative.
- S.I. unit of energy = joule (J)
Another popular unit is electron volt (eV).
 $1 \text{ eV} = 1.6 \times 10^{-19} \text{ joule}$.

Charged soap bubble

For equilibrium of a charged soap bubble, pressure due to surface tension = $\frac{4T}{r}$ acting inwards.

Electric pressure due to charging = $\frac{\sigma^2}{2\epsilon_0}$ acting outwards.

At equilibrium, $\frac{4T}{r} = \frac{\sigma^2}{2\epsilon_0}$ where σ = surface density of charge

$$\Rightarrow \frac{4T}{r} = \frac{1}{2\epsilon_0} \left(\frac{q}{4\pi r^2} \right)^2 \Rightarrow q = 8\pi r \sqrt{2\epsilon_0 r T}.$$

Here air pressures, inside and outside the bubble, are supposed to be same.

Behaviour of a conductor in an electrostatic field

In the case of a charged conductor

- (i) charge resides only on the outer surface of conductor.
- (ii) electric field at any point inside the conductor is zero.
- (iii) electric potential at any point inside the conductor is constant and equal to potential on the surface of the conductor, whatever be the shape and size of the conductor.
- (iv) Electric field at any point on the surface of charged conductor is directly proportional to the surface density of charge at that point, but electric potential does not depend upon the surface density of charge.

Capacitance

- When a conductor is given a charge, its potential gets raised. The quantity of charge given to a conductor is found to be directly proportional to the potential raised by it. If q is the charge given to conductor and V is potential raised due to it, then $q \propto V$ or $q = CV$, where C is a constant, known as **capacitance** of the conductor.
- Capacitance = charge/potential.
- Unit of capacitance is **farad**.
1F = 1 coulomb/volt.
- 1 Farad = 9×10^{11} stat farad.
- Dimensions of capacitance are $[M^{-1} L^{-2} T^4 A^2]$.
- **Capacity of an isolated spherical conductor** : Capacitance of an isolated spherical conductor of radius a placed in a medium of dielectric constant K ,
 $C = 4\pi\epsilon_0 K a$ farad
For vacuum or air, $K = 1$, hence
 $C_0 = 4\pi\epsilon_0 a$ farad.
i.e., capacitance of a spherical conductor \propto radius.
- **Capacitor** is a pair of two conductors of any shape which are close to each other and have equal and opposite charges.

- A capacitor is an arrangement which can store sufficient quantity of charge.
- The quantity of charge that can be given to a capacitor is limited by the fact that every dielectric medium becomes conducting at a certain value of electric field.
- Capacitance of a capacitor is
 - (i) Directly proportional to the area of the plates (A).
 - (ii) Inversely proportional to distance between plates (d)⁻¹.
 - (iii) Directly proportional to dielectric constant of the medium filled between its plates (K).
- **Parallel plate capacitor** : Capacitance of a parallel plate capacitor filled completely with some dielectric medium.

$$C = \frac{K\epsilon_0 A}{d}$$

- For air and vacuum, $K = 1$.

$$\therefore C_0 = \frac{\epsilon_0 A}{d}$$

- Capacitance of a parallel plate capacitor filled with dielectric slab of thickness t is given by

$$C = \frac{\epsilon_0 A}{d - t \left[1 - \frac{1}{K} \right]}$$

- Capacitance of a parallel plate capacitor filled with a conducting slab of thickness t is given by

$$C = \frac{\epsilon_0 A}{(d - t)}$$

- The plates of a parallel plate capacitor attract each other with a force $F = \frac{Q^2}{2A\epsilon_0}$.

- **Capacitance of a spherical condenser/capacitor**, is

$$C = 4\pi\epsilon_0 K [ab/(b - a)]$$

when a and b are the radii of inner and outer spheres respectively.

- **Dielectrics are of two types** : Non-polar and polar. The non-polar dielectrics (like N_2 , O_2 , benzene, methane) etc. are made up of non-polar atoms / molecules, in which the centre of mass of negative coincides with the centre of mass of negative charge of the atom / molecule.
- The polar dielectrics (like H_2O , CO_2 , NH_3 , HCl) etc. are made up of polar atoms / molecules, in which the centre of mass of positive charge does not coincide with the centre of mass of negative charge of the atom / molecule.
- A non-polar dielectric can be polarized by applying an external electric field on the dielectric.

- The effective electric field \vec{E} in a polarised dielectric is given by $\vec{E} = \vec{E}_0 - \vec{E}_p$

where \vec{E}_0 is strength of external field applied and \vec{E}_p is intensity of induced electric field set up due to polarization. It is equal to surface density of induced charge. The ratio $E_0 / E = K$, dielectric constant.

- When a dielectric slab is placed between the plates of a parallel plate capacitor, the charge induced on its sides due to polarization of dielectric is

$$q_i = q \frac{(K-1)}{K}.$$

- **Capacitors in series:** Equivalent capacitance of a series combination of capacitors is

$$\frac{1}{C} = \frac{1}{C_1} + \frac{1}{C_2} + \frac{1}{C_3} + \dots$$

- In series combination of capacitors, charge is same on each capacitor and is equal to charge supplied by source $CV = C_1V_1 = C_2V_2 = \dots$

- **Capacitors in parallel :** Equivalent capacitance of a parallel combination of capacitors is $C_p = C_1 + C_2 + C_3 + \dots$

- In parallel combination of capacitors, potential difference is same across each capacitor and is equal to applied potential difference $\frac{q}{C} = \frac{q_1}{C_1} = \frac{q_2}{C_2} = \dots$

- Electric potential energy stored in a charged conductor or capacitor is

$$U = \frac{1}{2}CV^2 = \frac{1}{2} \frac{q^2}{C} = \frac{1}{2} qV.$$

- The electric potential energy of capacitor resides in the dielectric medium between the plates of the condenser.

- When two charged conductors are connected together, the redistributed charges on them are in the ratio of their capacitance.

- When two charged conductors having charges q_1 and q_2 and capacitances C_1 and C_2 are connected together, then after redistribution of charges, the common potential is

$$V = \frac{q_1 + q_2}{C_1 + C_2} = \frac{C_1V_1 + C_2V_2}{C_1 + C_2}$$

where V_1 and V_2 are the initial potentials of the charged conductors.

- In case of charged capacitors, when plates of same polarity are connected together,

common potential $V = \frac{C_1V_1 + C_2V_2}{C_1 + C_2}$.

But when plates of opposite polarity are connected together, then common potential is

$$V = \frac{C_1V_1 - C_2V_2}{C_1 + C_2}.$$

- Total energy stored in any grouping of capacitors is equal to sum of the energies stored in individual capacitors.
- If n charged drops, each of capacity C , charged to potential V with charge q , surface density σ and potential energy U coalesce to form a single drop, then for such a drop,
 - total charge = nq
 - total capacity = $n^{1/3} C$
 - potential = $n^{2/3} V$
 - Surface density of charge = $n^{1/3} \sigma$,
 - and total potential energy = $n^{2/3} U$.
- **Sharing of charges**

- (i) **Common potential** : When two capacitors at different potentials V_1 and V_2 are connected, charged $q_1 (= C_1 V_1)$ and $q_2 (= C_2 V_2)$ are redistributed till a common potential V is reached. Then

$$V = \frac{\text{total charge}}{\text{total capacity}} = \frac{q_1 + q_2}{C_1 + C_2} = \frac{C_1 V_1 + C_2 V_2}{C_1 + C_2}.$$

- (ii) **Loss of energy** : During sharing of charges, energy is lost; mostly as heat, partly as cracking noise and partly as sparking light.

$$\text{Loss of energy} = \frac{1}{2} \frac{C_1 C_2 (V_1 - V_2)^2}{(C_1 + C_2)}.$$

Van de Graaff generator

- Van de Graaff designed this electrostatic machine in 1931 to build up high potential difference of the order of few million volt.
- The generator is based on the following points:
 - (i) The action of sharp points *i.e.* the phenomenon of corona discharge.
 - (ii) The property that the charge resides on the outer surface of a conductor. Charge given to a hollow conductor is transferred to outer surface and is distributed uniformly over it.
- The high potential generated is used to accelerate charged particles like electrons, protons, ions etc. The particles hit the target with the huge energy acquired and carry out the artificial transmutation etc.
- \therefore Capacity of a spherical shell = $4\pi\epsilon_0 R$

$$\therefore \text{Potential generated } V = \frac{\text{Charge } Q}{\text{Capacity}} \quad \text{or } V = \frac{Q}{4\pi\epsilon_0 R}.$$

The positive charge goes on accumulating on the large spherical conducting shell.

\therefore Energy of the ions to be accelerated = qV

where q denotes charge on the ion or particle accelerated to hit the required target.

End

current electricity

- **Electric current** - The rate of flow of charge through a cross section of some region of a metallic wire (or an electrolyte) is called the current through that region.
- If the rate of flow of charge is not constant then the current at any instant is given by the differential limit : $I = dQ/dt$.

If a charge Q flows through the circuit for time t , then

$$I = Q/t.$$

- The S.I unit of current is called **ampere** (A) (coulomb/second).
- In metallic conductors the current is due to the motion of electrons whereas in electrolytes and ionized gases, both electrons and positive ions move in opposite direction. The direction of current is taken as the direction in which positive charges move.
- In conduction although the current is only due to electrons, the current was earlier assumed to be due to positive charges flowing from the positive of the battery to the negative. The direction of current therefore is taken as opposite to the flow of electrons.
- **Electromotive force** - The emf (ϵ) of the source is defined as the workdone per unit charge in taking a positive charge through the seat of the emf from the low potential end to the high potential end. Thus,

$$\epsilon = W/Q.$$

When no current flows, the emf of the source is exactly equal to the potential difference between its ends. The unit of emf is the same as that of potential, i.e. volt.

- The average flow of electrons in the conductor not connected to battery is zero *i.e.* the number of free electrons crossing any section of the conductor from left to right is equal to the number of electrons crossing the section from right to left. Thus no current flows through the conductor until it is connected to the battery.
- **Drift velocity of free electrons in a metallic conductor** - In the absence of an electric field, the free electrons in a metal move randomly in all directions and therefore their average velocity is zero. When an electric field is applied, they are accelerated opposite to the direction of the field and therefore they have a net drift in that direction. However, due to frequent collisions with the atoms, their average velocity is very small. This average velocity with which the electrons move in a conductor under a potential difference is called the **drift velocity**.
- If E is the applied field, e is the charge of an electron, m is the mass of an electron and τ is the time interval between successive collisions (relaxation time), then the acceleration of the electron is

$$a = eE/m$$

- Since the average velocity just after a collision is zero and just before the next collision, it is $a\tau$, the drift velocity must be

$$v_d = \frac{eE}{m}\tau$$

- If I is the current through the conductor and n is the number of free electrons per unit volume, then it can be shown that $I = nAev_d$.
- The **mobility** μ of a charge carrier is defined as the drift velocity per unit electric field.

$$\mu = v_d/E$$

- **Current density (J)**

(i) $J = \frac{I}{\text{area}} = nev_d$ [$\because I = nev_d \times \text{area}$]

(ii) S.I. unit of $J = \text{Am}^{-2}$.

(iii) Current density is a vector quantity. Its direction is that of the flow of positive charge at the given point inside the conductor.

(iv) Dimensions of current density = $[\text{M}^0\text{L}^{-2}\text{T}^0\text{A}^1]$.

- **Current carriers:** The current is carried by electrons in conductors, ions in electrolytes and electrons and holes in semiconductors.
- **Ohm's law** - Physical conditions (such as temperature) remaining unchanged, the current flowing through a conductor is proportional to the potential difference across its ends. *i.e.* $V \propto I$ or $V = RI$.
The constant of proportionality R is called the resistance of the conductor. This law holds for metallic conductors.
- According to Ohm's law, the graph between V and I is a straight line. Ohm's law is not valid for semiconductors, electrolytes and electronic devices etc. These are called non-ohmic or non-linear conductors.

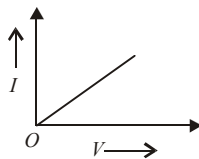

- The **resistance** of a conductor is a measure of the opposition offered by the conductor to the flow of current. This opposition is due to frequent collision of the electrons with the atoms of the conductor.
- The resistance of a conductor is directly proportional to its length l and inversely proportional to the area of cross-section A .

$$R = \rho \frac{l}{A}$$

where the constant ρ depends on the nature of the material. It is called the **resistivity** (or specific resistance) of the material. The S.I. unit of resistance is ohm (Ω) and resistivity is ohm-metre (Ωm).

- The resistivity of material of a conductor is given by

$$\rho = \frac{m}{ne^2\tau}$$

where n is number of free electrons per unit volume and τ is the relaxation time of the free electron. Its value depends on the nature of the material of the conductor and its temperature.

- The inverse of resistance is called **conductance** G .

$$G = 1/R.$$

Its S.I. unit Ω^{-1} is called **siemens** (S).

- The inverse of resistivity is called **conductivity**, σ .

$$\sigma = 1/\rho.$$

Its S.I. unit is $\Omega^{-1} \text{ m}^{-1}$ or S m^{-1} .

- The value of specific resistance or resistivity is low for metals, more for semiconductors and still greater for alloys like nichrome and manganin.
- Magnetic field applied to metals increases the resistivity/specific resistance of material. The exceptions are ferromagnetic materials like iron, cobalt and nickel wherein the resistivity decreases when magnetic field is applied.
- **Variation of resistivity of metals with temperature** : If ρ_0 and ρ_t are the values of resistivities at 0°C and $t^\circ\text{C}$ respectively then over a temperature range that is not too large, we have approximately,

$$\rho_t = \rho_0(1 + \alpha t)$$

where α is called the **temperature coefficient of resistivity** of the material.

- **Temperature coefficient of resistance (α)**

- If R_2 and R_1 represent resistances at temperatures $t_2^\circ\text{C}$ and $t_1^\circ\text{C}$, $\alpha = \frac{R_2 - R_1}{R_1(t_2 - t_1)}$.
- For metals, α is positive.
- For semiconductors, α is negative.
- For insulators, α is negative.
- For some alloys like nichrome, manganin and constantan, α is very low.

- **Non-Ohmic resistances**

- Ohm's law does not hold good for some substances and conductors. These are called non-ohmic resistances.
- Some examples are vacuum tubes (diode, triode), semiconductor diode, liquid electrolyte, transistor.

- **Superconductors** - A number of materials have the property that below a certain critical temperature, which is very close to absolute zero (0.1 K to 20 K), their resistivity suddenly drops to zero. Such a material is called a superconductor. A current once established in a superconductor continues for a long time without any driving field.

- Super conductors are those materials which offer almost zero resistance to the flow of current through them.
- Some known examples are mercury at 4.2 K, lead at 7.25 K and niobium at 9.2 K.
- Specific resistance of super conductor \approx zero.
- Specific conductance of super conductor \approx infinite.
- Temperature coefficient of resistance $\alpha \approx$ zero.

- The value of resistances used in electric and electronic circuit vary over a very wide range. Such high resistances used are usually carbon resistances and the values of such resistance are marked on them according to a **colour code**.

Colour	Figure
black	0
brown	1
red	2
orange	3
yellow	4
green	5
blue	6
violet	7
grey	8
white	9

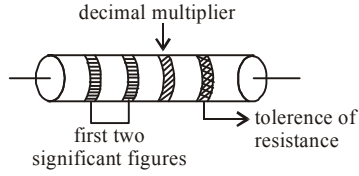

Colour	tolerance
gold	5%
silver	10%
no colour	20%

- For resistances in series, $R_{eq} = R_1 + R_2$

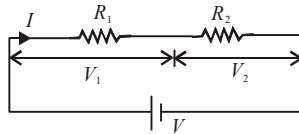

- In general, for n resistors in series, $R_{eq} = \sum_{i=1}^n R_i$.

- If $R_1 = R_2 = \dots R_n = R$, then $R_{eq} = nR$.

- In case of resistances in series, $\frac{V_1}{V_2} = \frac{R_1}{R_2}$

$$V_1 = \frac{VR_1}{R_1 + R_2} ; V_2 = \frac{VR_2}{R_1 + R_2}$$

as the current is the same.

- In series combination of resistors,
 - current through all the resistors is same
 - potential difference across a resistor is proportional to its resistance.
 - The equivalent resistance is greater than the greatest of the resistances connected in series.

- For resistances in parallel,

$$\frac{1}{R_{eq}} = \frac{1}{R_1} + \frac{1}{R_2} \quad \text{or,} \quad R_{eq} = \frac{R_1 R_2}{R_1 + R_2}$$

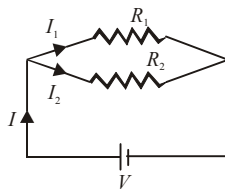

- In general, for n resistors in parallel

$$\frac{1}{R_{eq}} = \frac{1}{R_1} + \frac{1}{R_2} + \dots + \frac{1}{R_n}$$

If $R_1 = R_2 = \dots = R_n = R$, then $R_{eq} = R/n$.

- In parallel combination of resistors,
 - (i) potential difference across all of them is same
 - (ii) current through any resistance is inversely proportional to its resistance.
 - (iii) The equivalent resistance is less than the smallest of the resistances connected in parallel.
- In case of resistances in parallel, $\frac{I_1}{I_2} = \frac{R_2}{R_1}$.

Acid and alkali accumulators or storage cells are the secondary cells which have a low internal resistance. Hence a large current can be drawn from such cells. These can be charged and used again and again.

Acid accumulators have large e.m.f. but are delicate.

Alkali accumulators have low e.m.f. but are robust.

- **Internal resistance of a cell and terminal voltage**

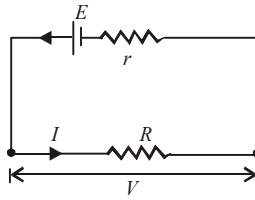

The resistance offered by the electrolyte to the flow of current through the cell is called the *internal resistance* of the cell.

$$V = E - Ir.$$

V is called the **terminal voltage**. If $I = 0$ then $V = E$.

- When a cell is charged by an external source V , then $V = E + Ir$.

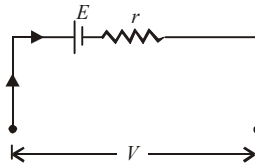

- **Cells in series :**

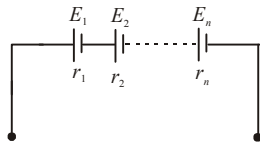

If n cells having emfs E_1, E_2, \dots, E_n and internal resistances r_1, r_2, \dots, r_n are connected in series as shown, then

$$E_{eq} = E_1 + E_2 + \dots + E_n.$$

and $r_{eq} = r_1 + r_2 + \dots + r_n$

In particular, if $E_1 = E_2 = \dots = E_n = E$ and $r_1 = r_2 = \dots = r_n = r$, then $E_{eq} = nE$ and $r_{eq} = nr$.

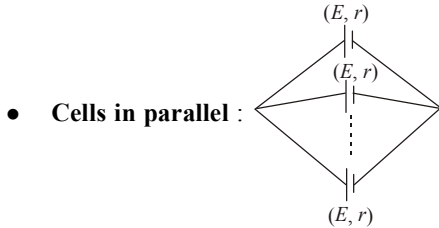

If n cells, each of emf E and internal resistance r are connected in parallel as shown, then

$$E_{eq} = E \quad \text{and} \quad r_{eq} = \frac{r}{n}$$

If the emfs of the cells are not all equal then we have to use Kirchhoff's rules.

- **Mixed combination of cells :** Consider a combination of cells having m rows, each row having n cells. Let the emf of each cell be E and its internal resistance be r .

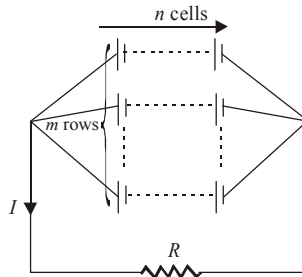

We have $E_{eq} = nE$, and $r_{eq} = \frac{nr}{m}$.
$$I = \frac{nE}{R + \frac{nr}{m}} = \frac{mnE}{mR + nr}$$

It can be shown that for I to be maximum, $mR = nr$.

- Cells are grouped in series if $R \gg r$.
- Cells are grouped in parallel if $r \gg R$.
- In a mixed grouping of cell, maximum current is available if the total internal resistance of battery is equal to external resistance.

$$R = \frac{nr}{m} \quad (m \text{ rows of } n \text{ cells each})$$

- Inside the cell, the current flows from negative plate to positive plate while outside the cell from positive plate to negative plate. But during charging of cell, this direction is reversed.
- When the cell is charged, then potential difference across the two plates (V) is greater than e.m.f. of cell.

$$V > E$$

- In open circuit when no current is drawn from a cell, $V = E$.
- When current is drawn from a cell, $V < E$.
- **Kirchhoff's rules :** All electrical networks cannot be reduced to simple series-parallel combinations. Kirchhoff gave two simple and general rules which can be applied to find the currents flowing through or voltage drops across resistances in such networks.

- **First rule (junction rule)** : The algebraic sum of the currents at a junction is zero.

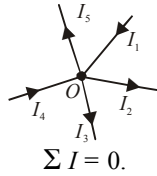

According to Kirchoff's first law, $I_1 - I_2 - I_3 + I_4 - I_5 = 0.$

This rule follows the conservation of charge, since no charges can accumulate at a junction. While applying this rule, we (arbitrarily) take the currents entering into a junction as positive and those leaving it as negative.

- **Second rule (loop rule)** : According to this rule in any closed part of an electrical circuit, the algebraic sum of the emfs is equal to the algebraic sum of the products of the resistances and currents flowing through them.

$$\Rightarrow \sum E = \sum IR$$

This rule follows from the law of conservation of energy.

The following procedure should be adopted while applying the rules to some network:

- In the resistors, $i \times R$ is +ve if it is against the current and -ve in the direction of the current.

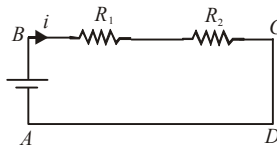

- Apply the junction rule for all junctions.
 - Choose any loop in the network and designate a direction, clockwise or anticlockwise, to traverse the loop.
 - In the cell, positive to negative terminals will be negative (down the potential) and positive to negative terminals will be positive if one takes from the negative terminal to the positive terminal (up the potential gradient).
 - If necessary, choose another loop and repeat steps (iii) and (iv) until there are as many equations as unknowns.
- **The Wheatstone's bridge** is an arrangement of four resistances P, Q, R and S connected as shown in the figure.

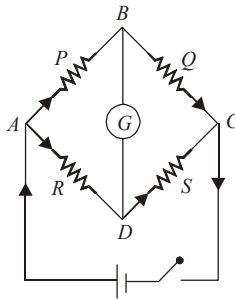

Their values are so adjusted that the galvanometer G shows no deflection. The bridge is then said to be balanced. When this happens, the points B and D are at the same potential and it can be shown that

$$\frac{P}{Q} = \frac{R}{S}$$

This is called the **balancing condition**. If any three resistances are known, the fourth can be found.

- Wheatstone's bridge is most sensitive when resistances in the four ratio arms are of the same order.
- The measurement of resistance by Wheatstone's bridge is not affected by the internal resistance of the cell.
- **The Metre Bridge** : The metre bridge is the practical application of the Wheatstone network principle in which the ratio of two of the resistances, say R and S , is deduced from the ratio of their balancing lengths. AC is a 1 m long uniform wire. If $AD = l$ cm, then $DC = (100 - l)$ cm.

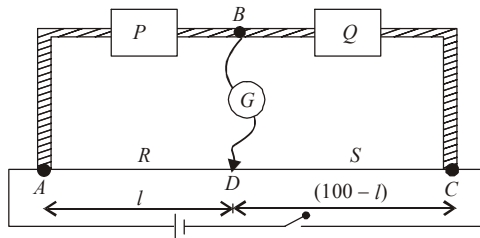

Clearly, $\frac{P}{Q} = \frac{l}{100 - l}$.

If P is known then Q can be determined.

- **Applications of metre bridge:**

(i) To measure unknown resistance, $X = \frac{R(100 - l)}{l}$.

Knowing the value of R and l , the value of X can be found.

(ii) To compare two unknown resistances $\frac{R_1}{R_2} = \frac{l_2 (100 - l_1)}{l_1 (100 - l_2)}$

Knowing the value of l_1 and l_2 , the ratio R_1/R_2 can be found.

(iii) To measure the unknown temperature $\theta = \frac{R - R_0}{R_{100} - R_0} \times 100$

The unknown resistance X (in form of metallic wire) is immersed in ice and its resistance R_0 at 0°C is measured. The unknown resistance is then maintained at a temperature of 100°C (by placing the wire in steam) and its resistance R_{100} at 100°C is measured. At last resistance is immersed in hot bath at unknown temperature θ and experiment is repeated to measure its resistance R_θ at 0°C . After substituting the value of R_0 , R_{100} and R_θ in the equation, the unknown temperature of the hot bath can be found.

- **Potentiometer** : It is a device commonly used for comparison of emfs of cells and for finding the internal resistance of a primary cell. A battery X is connected across a long uniform wire AB . The cells E_1 and E_2 whose emfs are to be compared are connected as shown along with a galvanometer G which detects the flow of current.

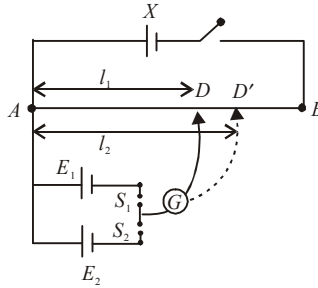

First the key S_1 is pressed which brings E_1 in the circuit. The sliding contact D is moved till the galvanometer shows no deflection. Let the length $AD = l_1$. Next S_1 is opened and S_2 is closed. This brings E_2 in the circuit. Let D' be the new null point and let $AD' = l_2$. Then, clearly,

$$\frac{E_1}{E_2} = \frac{l_1}{l_2}$$

- Potentiometer compares the true emfs of cells because no current flows through the cells at the balance points and therefore no errors are introduced due to internal resistances.
- To find the internal resistance of a primary cell, first the emf E of the cell is balanced against a length $AD = l$. A known resistance R is then connected to the cell as shown in the figure.

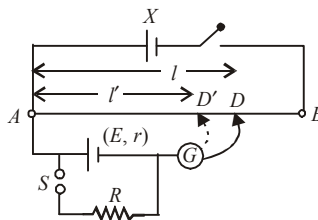

The terminal voltage V is now balanced against a smaller length $AD' = l'$.
Then, $E/V = l/l'$.

But we know that $\frac{E}{V} = \frac{R+r}{R}$.

Therefore, $\frac{R+r}{R} = \frac{l}{l'}$ or, $r = \left(\frac{l}{l'} - 1\right)R$.

- **Potentiometer** is an ideal voltmeter.
- Sensitivity of potentiometer is increased by increasing length of potentiometer wire.
- **Resistance of wire**

(i) If a resistance wire is stretched to a greater length, keeping volume (V) constant,

$$R = \rho \frac{l}{S} = \left(\frac{\rho}{V}\right) \cdot l^2$$

Suppose length is drawn to n times, $l' = nl$ then

$$R' = \left(\frac{\rho}{V}\right) n^2 l^2 = n^2 R$$

(ii) If a resistance wire is drawn to n times its radius, $r' = nr$

$$R = \frac{\rho l}{S} = \frac{\rho \cdot l}{\pi r^2} = \frac{\rho}{\pi r^2} \left(\frac{\text{volume}}{\pi r^2} \right) = \frac{\rho V}{\pi^2 r^4}$$

$$R' = \left(\frac{\rho V}{\pi^2} \right) \cdot \left(\frac{1}{nr} \right)^4 = \frac{\rho V}{\pi r^4} \cdot \frac{1}{n^4} = \frac{R}{n^4}$$

(iii) If a resistance wire is drawn to n times its area of cross-section S , keeping volume V constant, then $S' = nS$.

$$R = \frac{\rho l}{S} = \frac{\rho}{S} \times \left(\frac{\text{volume}}{S} \right) = \frac{\rho V}{S^2}$$

$$R' = \frac{\rho V}{(nS)^2} = \frac{\rho V}{S^2} \cdot \frac{1}{n^2} = \frac{R}{n^2}$$

A decorative symbol for the end of the text, consisting of the word "End" in a stylized, cursive font with a flourish above it.

thermal and chemical effects of current

Thermal effect

- The rate at which work is done by the source of emf in maintaining the electric current in a circuit is called **electric power** of the circuit.

$$P = VI$$

where V is the potential difference across the conductor, I is current flowing through the conductor.

- SI unit of electric power is watt.
 $1 \text{ W} = 1 \text{ V} \times 1 \text{ A}$
- Bigger unit of electric power
1 kilowatt (kW) = 10^3 W
1 megawatt (MW) = 10^6 W
- Other expressions for power
 $P = I^2R \Rightarrow P = V^2/R$
- The total workdone (or energy supplied) by the source of emf in maintaining the electric current in the circuit for a given time is called **electric energy** consumed in the circuit.
- Electric energy = electric power \times time
- SI unit of electric energy is joule but another unit is **watt hour**.
- The bigger unit of electric energy is kilowatt hour (kWh). It is known as **Board of Trade Unit (BOT)**.
- 1 kilowatt hour = $1000 \text{ watt} \times 1 \text{ hour}$
 $= (1000 \text{ J/s}) \times (3600 \text{ s}) = 3.6 \times 10^6 \text{ J}$
- 1 horse power = 746 watt.
- The electric energy consumed in kWh is given by
$$W (\text{in kWh}) = \frac{V (\text{in volt}) \times I (\text{in ampere}) \times t (\text{in hour})}{1000}$$
- Whenever the electric current is passed through a conductor, it becomes hot after some time. This indicates that the electric energy is being converted into heat energy. This effect is known as heating effect of current or **joule heating effect**.
$$H \propto I^2Rt$$
- $$H = W = I^2Rt \text{ joule} = \frac{I^2Rt}{4.18} \text{ calorie}$$

- **Maximum power theorem** : It states that the output power of a source of emf is maximum, when external resistance in the circuit is equal to the internal resistance of the source.
- Efficiency of an electric device is defined as the ratio of its output power to the input power.
i.e. $\eta = \frac{\text{power output}}{\text{power input}}$
- If 100 W-220 V is written on some electric instruments, then it simply means that on using the instrument on 200 V supply, 100 J of energy is consumed by it in one second.
- When bulbs are joined in parallel, voltage across each bulb will be same. Now, because resistance of highest wattage bulb is minimum, hence heat produced ($= I^2t/R$) (or brightness) will be maximum in highest wattage bulb.
- When bulbs are joined in series, current through each bulb will be same. Now because resistance of lowest wattage bulb is maximum, hence heat produced ($= I^2Rt$) will be maximum in lowest wattage bulb or lowest wattage bulbs glows with maximum brightness.
- A fuse wire is generally prepared from tin-lead alloy (63% tin + 37% lead). It should have high resistance and low melting point. It is used in series with the electrical installations and protects them from the strong currents.
- Electric iron, electric heater and heating rod are some of the important household electrical appliances whose working is based on the heating effect of electric current. In such appliances, the heating element used is of nichrome (an alloy of Ni and Cr).

Chemical effect

- The process of decomposition of electrolyte solution into ions on passing the current through it is called **electrolysis**. The liquid in which electrolysis take place is called **electrolyte**.
- **Electrodes** are two metal plates which are partially dipped in the electrolyte for passing the current through the electrolyte.
- The plate at which current enters the electrolyte is called **anode** and that at which current leaves the electrolyte is called **cathode**.
- The vessel in which the electrolysis is carried out is called a **voltameter**. It contain two electrodes and a solution electrolyte. It is also known as electrolytic cell.
- The ions which carry negative charge and move towards the anode during electrolysis are called **anions**. The ions formed when chemical reaction involves addition of electrons (i.e. reduction) are called **anions**.
- The ions which carry positive charge and move towards the cathode during electrolysis are called **cations**. The ions formed when chemical reaction involves removal of electrons (i.e. oxidation) are called **cations**.
- **Back emf** is the emf set up in an electrolytic cell or water voltameter which opposes the external d.c. supply applied to the cell or voltameter.
- The detailed experimental study of the electrolysis was carried out by **Michael Faraday**.

- **Faraday's first law** : It states that the mass of substance deposited at the cathode during electrolysis is directly proportional to the quantity of electricity (total charge) passed through the electrolyte.
- $m = Zit$, where m is the mass of the substance liberated, Z is the electrochemical equivalent (ECE) of the substance, I is the current passed through the electrolyte. This gives $m = Zq$.
- SI unit of electrochemical equivalent of a substance is kilogram coulomb⁻¹ (kgC⁻¹). In practice electrochemical equivalent of substance is expressed as gram coulomb⁻¹ (gC⁻¹).
- **Faraday's second law** : If some quantity of electricity is passed through different electrolytes, masses of the substance deposited at the respective cathode are directly proportional to their chemical equivalents.
 $m \propto E$, where m is mass of the ions of a substance liberated and E is chemical equivalent.

- Chemical equivalent = $\frac{\text{atomic weight}}{\text{valency}}$

- Let m_1, m_2 is masses of the substance liberated or deposited on various electrode when same current is passed for the same time through their electrolytes and E_1, E_2 is chemical equivalents of the substance liberated or deposited. The according to Faraday's second law of electrolysis,

$$\frac{m_1}{m_2} = \frac{E_1}{E_2}$$

- **Faraday's constant** is equal to the ratio of chemical equivalent of a substance to its electrochemical equivalent.

$$F = \frac{E}{Z} = \frac{qE}{m} \quad (\because m = Zq)$$

- One faraday = 96500 C/gram equivalent
- 96500 C of charge is required to liberate one gram equivalent of a substance of an electrode during electrolysis.
- Also Faraday's constant $F = Ne$, where N is the Avogadro's number and e is the electronic charge.
- **Electroplating** is a process of depositing a thin layer of one metal over another metal by the method of electrolysis. The article of cheap metal are coated with precious metal like silver and gold to make them look attractive.
- **Anodising** is the process of coating aluminium with its oxide electrochemically to protect it against corrosion.
- Electrolysis is used for local anaesthesia (when current is passed through a nerve, it is rendered insensitive to pain), and also for nerve stimulation especially of polio patients.
- An electrochemical cell or simply a cell is an arrangement, in which chemical reaction takes place at a steady rate, so as to convert chemical energy into electrical energy.

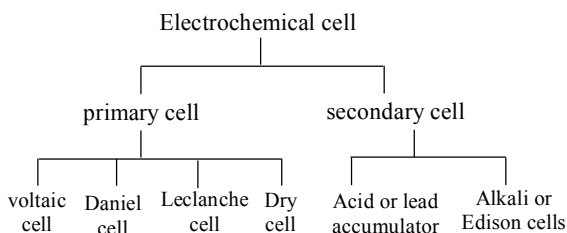

- **Primary cell** is an electrochemical cell, which once discharge, cannot be put to use again by passing electric current from an external source.
- **Secondary cell** is an electrochemical cell, which has to be charged initially by passing electric current from an external source, so as to convert the stored chemical energy into electrical energy.
- The initial cost of a primary cell is relatively low as compared to secondary cell, but its operating cost is quite high. The running cost of secondary cells is very low in the long run.
- The capacity of a source of emf is called **one ampere hour**, if it can discharge one ampere of current for one hour.
- The **button cell** are usually pellet type, flat in construction and look like a button shape. Owing to their small size, they are used in small electronic devices so as to minimise space and weight.
- The mercury button cell is an alkaline cell of emf 1.36 and zinc-air button cell provides an emf of 1.4 V.
- **Chemical effect :**
 1. For electrolysis of acidulated water practically required minimum voltage is 1.7 volt.
 2. For electrolysis D.C. is required.
 3. Electrolytic current does not obey ohm's law except for a very small value of electrolysis.

Thermoelectric effect

- A thermocouple is an arrangement of two suitable dissimilar metallic wires (wires of different materials) joined at their ends to form junctions.
- The conversion of heat into electrical energy by using a thermocouple is called **thermoelectricity**.
- **Seebeck effect** is the phenomenon of generation of an electric current in a thermocouple by keeping its two junctions at different temperatures.

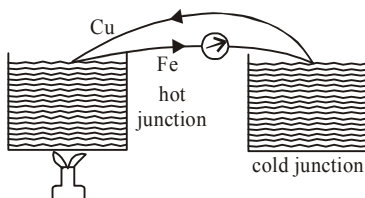

- **Applications**

- (i) For the measurement of current (AC and DC) apparatus.
- (ii) For the measurement of temperature

- **Direction of thermo-current**

Hot Coffee \Rightarrow thermo electric current from Cu to Fe through hot junction.

ABC \Rightarrow Current from **Antimony (Sb)** to **Bismuth** via **Cold** junction.

- The thermo emf developed in a thermocouple depends upon the nature of metals forming the thermo-couple and difference in temperature of the two junctions.
- On the basis of Seebeck experimental results, he arranged a number of metals in the form of a series, called thermoelectric series.
- The series is given below.
Bi, Ni, Co, Pd, Pt, Cu, Mn, Hg, Pb, Sn, Au, Zn, Cd, Fe, Sb, Te.
- Seebeck also found experimentally that for a given difference of temperatures of two junctions, the larger is the gap in Seebeck series between the metals joining the thermocouple, the greatest will be the thermo emf generated.
- The temperature of hot junction at which thermo emf in a thermocouple is maximum is called **neutral temperature**.
- The value of neutral temperature is a constant for thermocouple. Its value depends upon the nature of material forming the thermocouple and independent of the temperature of the cold junction.

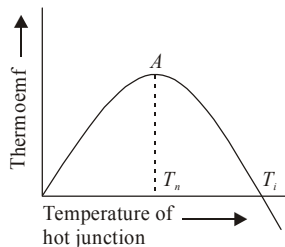

- The temperature of hot junction at which the thermo- emf in a thermocouple become zero and just beyond, it reverses its direction is called **temperature of inversion**.
- The value of temperature of inversion depends upon the temperature of the cold junction and the nature of materials forming the thermocouple.
- Relation between thermo emf and temperature of hot junction.

$$E = \left(\alpha\theta + \frac{1}{2}\beta\theta^2 \right)$$

where α and β are constants called **thermo electric constants**.

- The rate of change of thermo emf with change in the temperature of the hot junction is called **thermoelectric power**.
- A **thermopile** is a combination of a large number of thermocouples in series. It can be used to detect the heat radiations.
- **Peltier effect** : If a current is passed round the conductors of a thermo couple, one junction gets heated and other junction gets cooled. The phenomenon is called **Peltier**

effect. It is a reversible effect. The amount of heat absorbed or evolved depends on charge passed.

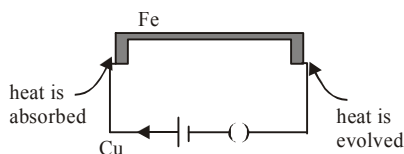

Heat : H (joule) $\propto Q$ coulomb

$H = \pi Q = \pi It$; π = Peltier coefficient or Peltier emf

- **Thomson effect** : If a current is sent through a single unequally heated conductor absorption or evolution of heat takes place throughout the conductor or if a temperature difference exists between two points of a conductor, a potential difference is developed between the points. This phenomenon is called **Thomson effect**. It is also reversible effect. For lead (Pb) Thomson coefficient is zero.
- **Thermoelectric thermometer** : It is a device used to measure both low and high temperatures. Thermoelectric thermometers have much wider range of measurement of temperature (from -200°C to 1600°C). They are quite sensitive and can measure temperature accurately upto 0.05°C . Disadvantage of thermometer is that it does not give direct reading and hence it cannot be used in experiments on calorimetry.

End

magnetic effect of current

- **Hans Christian Oersted** observed that, when a compass is placed near a straight wire carrying a current, the compass needle aligns so that it is tangent to a circle drawn around the wire (neglecting the influence of the Earth's magnetic field on the compass).
- Oersted's discovery provided the first link between electricity and magnetism.
- The space or region around the current carrying conductor within which its influence can be felt by the magnetic needle is called the **magnetic field** of the current carrying conductor in general way.

However, the definition of \vec{B} can be given as the number of lines of magnetic field per unit area or the force acting on unit charge which is moving with unit velocity perpendicular to the magnetic field.

- S.I. unit of magnetic field is Wm^{-2} or T (tesla).
- The strength of magnetic field is called one tesla, if a charge of one coulomb, when moving with a velocity of 1 ms^{-1} along a direction perpendicular to the direction of the magnetic field experiences a force of one newton.

$$\begin{aligned} 1 \text{ tesla (T)} &= 1 \text{ weber metre}^{-2} \text{ (Wb m}^{-2}\text{)} \\ &= 1 \text{ newton ampere}^{-1} \text{ metre}^{-1} \text{ (N A}^{-1}\text{m}^{-1}\text{)} \end{aligned}$$

- C.G.S. units of magnetic field are called gauss or oersted.
 $1 \text{ gauss} = 10^{-4} \text{ tesla.}$
- **Right hand thumb rule** : If the linear conductor is grasped in the palm of the right hand with thumb pointing along the direction of the current, then the curl fingers will point in the direction of lines of force.

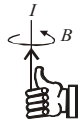

- **Maxwell's cork screw rule** : If a right handed cork screw is rotated so that its tip moves in the direction of flow of current through the conductor, then the rotation of the head of the screw gives the direction of magnetic lines of force.
- The conventional sign for a magnetic field coming out of the plane and normal to it is a dot i.e. \odot . The magnetic field perpendicular to the plane in the down ward direction is denoted by \otimes .

- **Biot savart's Law:** According to this law, the magnetic field (in magnitude) due to a current element of length dl carrying a current I at a point at distance r from it, is given by

$$|\overline{dB}| = \frac{\mu_0 I}{4\pi} \cdot \frac{|\overline{dl} \times \hat{r}|}{r^2} = \frac{\mu_0}{4\pi} \cdot \frac{I dl \sin\theta}{r^2}$$

where θ is the angle between the direction of the current and the line joining the current element to the point and μ_0 is absolute permeability of the free space ($\mu_0 = 4\pi \times 10^{-7} \text{ T A}^{-1} \text{ m}$).

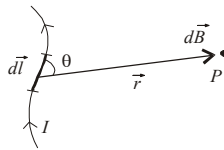

The direction of magnetic field \overline{dB} is that of $I \overline{dl} \times \overline{r}$.

- **Magnetic field due to a current carrying conductor:**

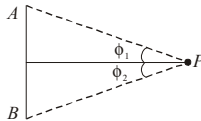

The magnetic field at a point at perpendicular distance a from a straight conductor carrying current I is given by

$$B = \frac{\mu_0}{4\pi} \cdot \frac{I}{a} (\sin \phi_1 + \sin \phi_2),$$

where ϕ_1 and ϕ_2 are angles, which the lines joining the two ends of the conductor to the observation point make with the perpendicular from the observation point to the conductor.

In case, the straight conductor is of infinite length ($\phi_1 \cong \phi_2 \cong \frac{\pi}{2}$), the magnetic field is

given by

$$B = \frac{\mu_0}{4\pi} \cdot \frac{2I}{a}$$

- **Magnetic field due to a current carrying circular coil:** For a coil of radius a , consisting of N turns and carrying current I ,

(i) the magnetic field at a point on axis at distance d from its centre is given by

$$B = \frac{\mu_0}{4\pi} \cdot \frac{2\pi N I a^2}{(a^2 + d^2)^{3/2}}$$

(ii) the magnetic field at its centre is given by

$$B = \frac{\mu_0}{4\pi} \cdot \frac{2\pi N I}{a}$$

- The current carrying loop behaves as a small magnetic dipole placed along the axis one face of the loop behaves as north pole while the other face of loop behaves as south pole.

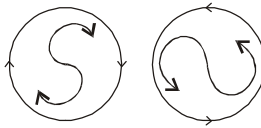

- The face in which the current is flowing in clockwise direction behaves as south pole while the face through which the current is flowing in anticlockwise direction behaves as north pole.
- **Ampere's circuital law** states that the line integral of the magnetic field around any closed path in free space is equal to absolute permeability (μ_0) times the net current enclosed by the path.

$$\oint \vec{B} \cdot d\vec{l} = \mu_0 I$$

where \vec{B} is the magnetic field $d\vec{l}$ is small element, μ_0 is the absolute permeability of free space and I is the current.

- Ampere's circuital law holds good for a closed path of any size and shape around a current carrying conductor because the relation is independent of distance from conductor.
- A straight solenoid consists of hollow tube over which a large number of turns of insulated copper wire are uniformly wound.

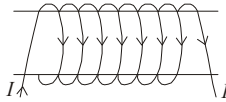

- If a solenoid of n turns per unit length carries a current I , then
 - (i) magnetic field at a point well inside the solenoid is given by
 - (ii) magnetic field at a point on one end of the solenoid is given by

$$B = \mu_0 n I$$

$$B = \frac{1}{2} \mu_0 n I$$

- A toroidal solenoid is an anchor ring around which is large number of turns of a copper wire are wrapped.

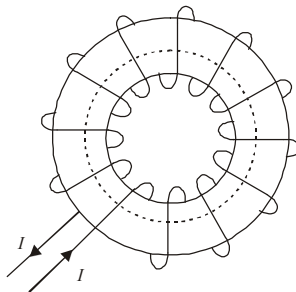

- The magnetic field produced in toroid will be same at all points on the circumference of the circle and at any point it will act along the tangent to the ring

$$B = \frac{\mu_0 NI}{2\pi r}$$

- For any point inside the empty space surrounded by the toroid and outside the toroid, magnetic field is zero because the net current enclosed in these space is zero.
- Magnetic field intensity at a point outside the cylinder ($r > a$)

$$B = \frac{\mu_0 I}{2\pi r}$$

- The magnetic field intensity at a point outside the cylinder varies inversely as the distance of the point from the axis of the cylinder.
- Magnetic field intensity on the surface of the cylinder ($r = a$)

$$B = \frac{\mu_0 I}{2\pi a}$$

- Magnetic field intensity at a point inside the cylinder. ($r < a$)

$$B = \frac{\mu_0 I r}{2\pi a^2}$$

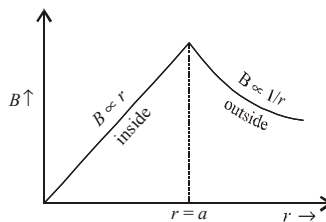

- Force on a charge in electric field:** A charge q inside an electric field of strength \vec{E} experiences force \vec{F} , which is given by

$$|\vec{F}| = |q\vec{E}| = qE$$

- Motion of a charge inside electric field:** If a potential difference V is applied between two parallel plates, a uniform electric field is set up between the plates. Its strength is given by $E = V/d$

A charge q of mass m experiences force $F = qE$,

which produces an acceleration, $a = \frac{qE}{m}$

The charge entering an electric field into perpendicular direction or at an angle follows a parabolic path.

- Fleming's Left hand rule :** It states that if the forefinger, central finger and thumb are stretched at right angles to each other then, central finger represents the direction of current, fore finger represents field and thumb represents force.
- Lorentz force:** The total force experienced by a charge moving inside the electric and magnetic fields is called Lorentz force. It is given by

$$\vec{F} = q(\vec{E} + \vec{v} \times \vec{B})$$

- **Motion of charge inside magnetic field:** A charge q of mass m moving with velocity \vec{v} inside a magnetic field of strength \vec{B} experiences force,

$$|\vec{F}| = q|\vec{v} \times \vec{B}| = Bqv\sin\theta$$

where θ is angle between the direction of motion of charge (\vec{v}) and the direction of magnetic field (\vec{B}). This force acts perpendicular to both \vec{v} and \vec{B} i.e. the direction of motion of the charge and the direction of applied magnetic field.

- The charge does not experience any force, if it is at rest or if it moves along the direction of magnetic field. The force is maximum, when charge moves perpendicular to the direction of magnetic field.

(i) If \vec{v} and \vec{B} are perpendicular ($\theta = 90^\circ$), the force on the charged particle makes it to move along circular path, whose radius is given by

$$r = \frac{mv}{Bq}$$

(ii) If \vec{v} and \vec{B} act at an angle θ , then due to the component of velocity $v \sin \theta$ (perpendicular to \vec{B} , the charge moves along circular path of radius r , which is given by)

$$r = \frac{mv\sin\theta}{Bq}$$

while due to the component of velocity $v\cos\theta$ (along \vec{B}), the charge at the same time moves along the direction of magnetic field. As a result, the charge moves along a **helical path** and pitch of the helical path is given by

$$\text{pitch} = \frac{2\pi m v \cos\theta}{Bq}$$

- **Cyclotron** is a particle accelerator and is used to accelerate positive ions. Under the action of magnetic field, the positive ions move along spiral path and gain energy as they cross the alternating electric field again and again.
- Cyclotron is based on the principle that the positive ions can be accelerated to high energies with a comparatively smaller alternating potential difference by making them to cross the electric field again and again, by making use of a strong magnetic field.
- In a cyclotron, the frequency of applied alternating electric field is equal to frequency of oscillation of the positive ion and this frequency is called **cyclotron frequency**. It is given by

$$\nu = \frac{Bq}{2\pi m}$$

where m and q are mass and charge of the positive ion and B is strength of the magnetic field.

- The positive ions of charge q and mass m in cyclotron attain maximum energy which is given by

(i) $E_{\max} = \frac{1}{2} \cdot \frac{B^2 q^2 R^2}{m}$ where R is radius of the dees of the cyclotron.

$$(ii) E_{\max} = 2n (Vq) .$$

where n is number of revolutions completed by the positive ions before leaving the dees.

- **Limitations of the cyclotron**

(i) Cyclotron can not accelerate uncharged particle like neutron.

(ii) The positively charged particles having large mass i.e. ions cannot move at limitless speed in a cyclotron.

- **Force on a current carrying conductor placed inside a magnetic field:** A conductor of length l carrying current I and placed inside a magnetic field of strength \vec{B} is given by

$$|\vec{F}| = I|\vec{l} \times \vec{B}| = BIl \sin\theta$$

- The conductor experiences maximum force, when the magnetic field acts at right angle to the length of the conductor; and the force is zero, when the length of the conductor is parallel to the direction of the magnetic field.
- **Force between two infinitely long parallel current carrying conductors.** When two infinitely long parallel conductors carrying currents I_1 and I_2 are placed a distance r apart, then force on the unit length of a conductor due to the other conductor is given by

$$F = \frac{\mu_0}{4\pi} \cdot \frac{2 I_1 I_2}{r}$$

The force is attractive, if currents in two conductors is in same direction; and repulsive, if currents are in opposite directions.

- If the currents in both parallel wires are equal and in same direction then magnetic field at a point exactly half way between the wire is zero.
- **Torque on a current carrying coil placed inside a magnetic field:** When a coil of area A having N turns and carrying current I is suspended inside a magnetic field of strength B , then torque on the coil is given by

$$\tau = NBIA \sin\theta,$$

when θ is angle between the direction of magnetic field and normal to the plane of the coil.

- If the direction of magnetic field makes an angle α with the plane of the coil, then
- $$\tau = NBIA \cos\alpha.$$
- The torque on the coil is maximum, when the plane of the coil is parallel to the magnetic field i.e. $\theta = 90^\circ$ or $\alpha = 0^\circ$
 - **Moving coil galvanometer** is a device used to detect or measure small electric current in the electric circuit.
 - When a current carrying loop or coil is placed in the uniform magnetic field, it experience a torque. This basic principle is used in moving coil galvanometer.
 - The deflection of the coil in moving coil galvanometer is directly proportional to current flowing through it

$$I \propto \theta$$

$$I = G \theta$$

where $G = \frac{k}{NAB} =$ galvanometer constant

k = The restoring torque per unit twist

N = Number of turns in the coil

A = Area of coil

B = Intensity of magnetic field

- **Sensitivity of a galvanometer.** A galvanometer is said to be sensitive, if it gives a large deflection, even when a small current is passed through it or when a small voltage is applied across its coil.
- **Current sensitivity.** It is defined as the deflection produced in the galvanometer on passing unit current through its coil.

$$\text{Current sensitivity, } \frac{\theta}{I} = \frac{NBA}{k} (\text{rad A}^{-1})$$

- **Voltage sensitivity.** It is defined as the deflection produced in the galvanometer, when a unit voltage is applied across its coil.

$$\text{Voltage sensitivity, } \frac{\theta}{V} = \frac{NBA}{kR} (\text{rad V}^{-1})$$

Here, R is resistance of the coil of the galvanometer.

- A small resistance usually put in parallel to the coil of a galvanometer is called **shunt**. The most part of the current in the circuit passes through the shunt and thus shunt allows only a very small part of current to pass through the galvanometer.

- **Ammeter** is an instrument used to measure current in an electrical circuit.

A galvanometer of resistance G can be converted into an ammeter of range I by putting a small resistance S in parallel to its coil, which is given by

$$S = \frac{I_g \times G}{I - I_g}$$

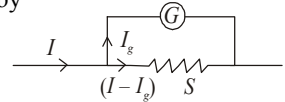

Here, I_g is maximum current that can pass through the galvanometer.

The resistance of the ammeter so obtained is given by $R_A = \frac{GS}{G+S}$

Ammeter is a low resistance instrument and it is always connected in series to the circuit.

- **Voltmeter.** It is an instrument used to measure potential difference across a conductor in an electrical circuit.

A galvanometer of resistance G can be converted into a voltmeter to read upto V by connecting a large resistance R in series to its coil, which is given by

$$R = \frac{V}{I_g} - G$$

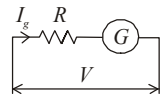

The resistance of the voltmeter so obtained is given by

$$R_V = G + R$$

Voltmeter is a high resistance instrument and it is always connected in parallel to the conductor, across which potential difference is to be measured.

End

magnetism

- The term **magnetism** usually refers to the property by virtue of which a piece of iron or steel is attracted.
- A **natural magnet** is an ore of iron (Fe_3O_4) which attracts small pieces of iron, cobalt and nickel towards it.
- **Lode stone** is a natural magnet.
- The magnets which are prepared artificially are called **artificial magnets**. *e.g.* a bar magnet, a magnetic needle, electromagnet, a horse-shoe magnet etc.
- According to molecular theory, every molecule of a magnetic substance (whether magnetised or not) is a complete magnet itself.
- The **poles** of a magnet are the two points near but within the ends of the magnet, at which the entire magnetism can be assumed to be concentrated.
- The poles always occur in pairs and they are of equal strength. Like poles repel and unlike poles attract.
- When a magnet is suspended freely, it comes to rest along north-south direction. The end point towards geographic north is called north pole and the end point towards geographic south is called south pole.
- **Coulomb's law** : The force between any two magnetic poles is directly proportional to the product of their pole strengths and inversely proportional to the square of the distance between them.
- The **force** between two point poles of strength m_1 and m_2 at a distance d apart is given by

$$F = \frac{\mu m_1 m_2}{4\pi d^2}, \text{ where } \mu \text{ is called the } \mathbf{absolute\ permeability} \text{ of the medium.}$$

- Also, $\mu = \mu_0 \mu_r$, where $\mu_0 = 4\pi \times 10^{-7}$ henry/metre is the permeability of free space and μ_r is the relative permeability of the medium. μ_0 is also expressed as TmA^{-1} ($\text{T} = \text{tesla}$).
- **Unit pole** is defined as that pole which when placed in vacuum (or in air) at a distance of one meter from an equal and similar pole, repels it with a force equal to 10^{-7} newton.
- An arrangement of two unlike poles of equal strength and separated by a small distance is called **magnetic dipole**.

The distance $2l$ between the two magnetic pole is called the magnetic length of the magnetic dipole is denoted by $(2\vec{l})$, a vector from south to north pole of the magnetic dipole.

- **Magnetic dipole moment:** The product of the pole strength of either magnetic pole and the magnetic length of the magnetic dipole is called its magnetic dipole moment. It is denoted by $\vec{M} = m(2\vec{l})$. Here, m is pole strength of the magnetic dipole. S.I. unit of magnetic dipole moment is (Am^2).
- **Magnetic lines of force :** Magnetic lines of force are imaginary curves.
- These are continuous and closed curves. Inside the magnet, they travel from south pole to north pole. Outside the magnet, they travel from north pole to south pole. They have neither a beginning nor an end.
- They are crowded near the poles indicating a stronger magnetic field near the poles.
- Tangent drawn to the curve at any point denotes the direction of magnetic field at that point.
- Lines of force are drawn equidistant and parallel to each other to indicate a uniform magnetic field.
- No line of force passes through a neutral point situated in the magnetic field of a magnet.
- Lines of force never intersect each other. At a point, the field has one direction only.
- **Magnetic field due to a bar magnet:** The magnetic field due to a bar magnet of length $2l$ and having magnetic dipole moment M at a distance r from its centre

(i) on its axial line is given by

$$B = \frac{\mu_0}{4\pi} \cdot \frac{2Mr}{(r^2 - l^2)^2} \approx \frac{\mu_0}{4\pi} \cdot \frac{2M}{r^3} \quad (r \gg l)$$

(ii) on its equatorial line is given by

$$B = \frac{\mu_0}{4\pi} \cdot \frac{M}{(r^2 + l^2)^{3/2}} \approx \frac{\mu_0}{4\pi} \cdot \frac{M}{r^3} \quad (r \gg l)$$

- **Torque on a magnetic dipole in a magnetic field:** When a magnetic dipole of magnetic dipole moment \vec{M} is placed in a uniform magnetic field of strength \vec{B} making an angle θ with the direction of magnetic field, it experiences a torque, which is given by

$$|\vec{\tau}| = |\vec{M} \times \vec{B}| = MB \sin\theta$$

- Magnetic dipole moment can be defined as the torque acting on a magnetic dipole placed normal to a uniform magnetic field of unit strength.
- **Potential energy stored in a magnetic dipole on rotating inside a magnetic field:** The work done in rotating a magnetic dipole against the torque acting on it, when placed in magnetic field is stored inside it in the form of potential energy. When magnetic dipole is rotated from initial position $\theta = \theta_1$ to final position $\theta = \theta_2$ then, potential energy stored is given by

$$U = -MB (\cos\theta_2 - \cos\theta_1)$$

- A current carrying loop behaves as a magnet i.e. magnetic dipole. Thus magnetic dipole moment of a current loop *i.e.*

$$M = IA$$

where A = area of the loop.

- In an atom, electrons revolve around the nucleus in circular orbits. The movement of the electron in circular orbit around the nucleus in anticlockwise direction is equivalent to the flow of current in the orbit in clockwise direction. Thus the orbit of electron is considered as tiny current loop.

$$\Rightarrow M = \frac{eL}{2m}$$

- Bohr Magneton (μ_B) = $\frac{eh}{4\pi m}$.
- A current carrying straight solenoid behaves like a bar magnet.
- **Geographic meridian:** An imaginary vertical plane passing through the axis of rotation of the earth is called the geographic meridian.
- **Magnetic meridian:** An imaginary vertical plane passing through the axis of a freely suspended magnet is called the magnetic meridian. It represents the direction of earth's magnetic field.
- **Magnetic elements:** The quantities, magnetic declination, magnetic inclination (dip) and horizontal component of earth's magnetic field completely determine the earth's magnetic field at a given place and are called magnetic elements.
- **Magnetic declination** at a place is the angle between the geographic meridian and magnetic meridian. It is denoted by θ .

Magnetic inclination (dip) at a place is the angle between the direction of the intensity of the total earth's magnetic field and the horizontal. It is denoted by δ .

- The figure shows two imaginary vertical planes known as geographical and magnetic meridians.

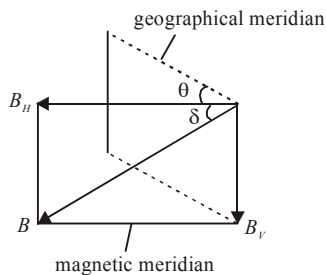

θ = angle of declination, δ = angle of dip

B = total intensity of earth, B_H = horizontal component

B_V = vertical component of earth's field B .

From geometry of figure, $B_H = B \cos \delta$

$$B_V = B \sin \delta$$

$$B_V^2 + B_H^2 = B^2$$

$$\frac{B_V}{B_H} = \tan \delta.$$

- Angle of dip δ is zero at magnetic equator. Hence on magnetic equator, $B_H = B$, $B_V = 0$.
- Angle of dip δ is 90° at the poles. Hence at poles, $B_V = B$, $B_H = 0$.

- When the magnetic needle oscillates in the vertical east-west plane, at right angles to magnetic meridian, then only B_V acts on it.
- When the dip needle oscillates at right angles to the magnetic meridian in a horizontal plane, then only B_H acts on it.
- When the dip needle oscillates in the vertical plane in magnetic meridian, then both the components B_V and B_H of earth's magnetic field act upon it.
- The horizontal component of earth's magnetic field B_H acts from south to north direction.
- **Magnetic latitude**
 - (i) If at any place, the angle of dip is δ and magnetic latitude is λ , then $\tan\delta = 2\tan\lambda$.
 - (ii) The total intensity of earth's magnetic field

$$I = I_0\sqrt{1 + 3\sin^2\lambda} \quad \text{where } I_0 = M/R^3.$$

It is assumed that a bar magnet of earth has magnetic moment M and radius of earth is R .

- (iii) At magnetic equator of earth, $\lambda = 0$ and at poles of earth $\lambda = 90^\circ$. Hence $I_P = 2I_E$.
- Angle of declination = 17° .
 - (i) At magnetic poles, a freely suspended magnetic needle becomes vertical.
 - (ii) At magnetic equator, a freely suspended magnetic needle becomes horizontal.
 - The resultant magnetic field of earth B is in the magnetic meridian.
 - **Magnetic maps** are maps obtained by drawing lines passing through different places on the surface of earth, having the same value of a magnetic element.
 - A line drawn through points of equal declination is called **isogonal line**.
 - A line drawn through points of zero declination is called **agonal line**.
 - A line passing through places of same value of dip is called **isoclinic line**.
 - Isoclinic line corresponding to zero dip is called **acclinic line**, or **magnetic equator**.
 - A line passing through places having equal values of B_H is called **isodynamic line**.
 - **Neutral point** : It is that point, where the magnetic field due to a bar magnet is completely cancelled by the horizontal component of earth's magnetic field.
 - (i) When a bar magnet is placed with its north pole towards south of the earth, the neutral points are obtained on axial line of the magnet. If d is the distance of the neutral point from the centre of the magnet,

$$\frac{\mu_0}{4\pi} \cdot \frac{2Md}{(d^2 - l^2)^2} = B_H$$

- (ii) When a bar magnet is placed with its north pole towards north of the earth, the neutral points are obtained on equatorial line of the magnet. If d is the distance of the neutral point from the centre of the magnet,

$$\frac{\mu_0}{4\pi} \cdot \frac{M}{(d^2 + l^2)^{3/2}} = B_H$$

- **Tangent law**: It states that when a short bar magnet is suspended freely under the combined action of two uniform magnetic fields of intensities B and B_H acting at 90°

to each other, the magnet comes to rest making an angle θ with the direction of magnetic field B_H , such that

$$B = B_H \tan\theta$$

- **Tangent galvanometer:** A tangent galvanometer is a moving magnet and fixed coil type galvanometer. It is based on tangent law and is used to measure very small currents. If a tangent galvanometer has coil of radius R and number of turns N , then deflection θ produced on passing current I is given by

$$I = \frac{2R}{N\mu_0} B_H \tan\theta = \frac{B_H}{G} \tan\theta = K \tan\theta$$

Here, $G = \frac{N\mu_0}{2R}$ is called galvanometer constant and

$$K = \frac{B_H}{G} = \frac{2R}{N\mu_0} B_H \text{ is called reduction factor of tangent galvanometer.}$$

- **Deflection magnetometer** is an instrument used for magnetic measurements.
- A deflection magnetometer is said to be set for **Tan A position**, when the magnetometer board axis is parallel to the pointer reading $0^\circ - 0^\circ$.
- A magnetometer is said to be set for in **Tan B position** when the magnetometer board is parallel to the magnet with the pointer reading $0^\circ - 0^\circ$.

- In **Tan A position**, $\frac{M}{B_H} = \frac{4\pi}{\mu_0} \left[\frac{(d^2 - l^2)^2 \tan\theta}{2d} \right]$.

For a short magnet, $\frac{M}{B_H} = \frac{4\pi}{\mu_0} \left[\frac{d^3 \tan\theta}{2} \right]$.

- In **Tan B position**, $\frac{M}{B_H} = \frac{4\pi}{\mu_0} [(d^2 + l^2)^{3/2} \tan\theta]$.

For a short magnet, $\frac{M}{B_H} = \frac{4\pi}{\mu_0} [d^3 \tan\theta]$.

- **Vibration magnetometer** is used for comparing magnetic moments of two magnets and also for comparing the horizontal component of earth's field at two places.
- In a vibration magnetometer, the **period of oscillation**, T is given by $T = 2\pi\sqrt{I/MB_H}$, where I is the moment of inertia of the magnet about the suspension.
- **Frequency** of oscillation in a vibration magnetometer is given by $n = \frac{1}{2\pi}\sqrt{MB_H/I}$.
- If two magnets are placed one above the other symmetrically and allowed to oscillate with a period, T_1 in a horizontal plane with a uniform field and with a period T_2 when

one of the magnets is reversed, then $\frac{M_1}{M_2} = \frac{T_2^2 + T_1^2}{T_2^2 - T_1^2}$, M_1 and M_2 being the moments of the magnets.

• **Magnetic quantities -Units and dimensions**

S.No.	Quantity	S.I. Unit	Dimensions
1.	Magnetic moment (vector quantity), $M = IA$, $M = m \times l$	Am^2	L^2A^1
2.	Pole strength (scalar), $m = M/l$, $m = F/B$	Am	LA
3.	Intensity of magnetisation (vector) $I = M/V$	Am^{-1}	L^{-1}A
4.	Magnetic flux (scalar) $\phi = BA$	weber	$\text{ML}^2\text{T}^{-2}\text{A}^{-1}$
5.	Magnetic induction (vector) $B = \phi$ $1 \text{ T} = 10^4 \text{ gauss (cgs)}$	Wb m^{-2} or tesla	$\text{MT}^{-2}\text{A}^{-1}$
6.	Intensity of magnetic field (vector) $H = nI$, $H = B/\mu$ $1 \text{ AM}^{-1} = 4\pi \times 10^{-3} \text{ oersted (cgs unit)}$	Am^{-1}	L^{-1}A
7.	Magnetic permeability (scalar), $\mu = B/H$	henry/m	$\text{MLT}^{-2}\text{A}^{-2}$
8.	Relative permeability (scalar), $\mu_r = \mu/\mu_0$	unitless	zero dimension
9.	Magnetic susceptibility (scalar) $\chi_m = I/H$, $\chi_m = (\mu_r - 1)$	unitless	zero dimension
10.	Periodic time of a magnet (scalar) $T = 2\pi \sqrt{\frac{I}{MB_H}}$ ($I = \text{moment of inertia}$)	sec	T

- **Magnetic flux (ϕ):** The number of lines of force passing through a given area is known as magnetic flux. It is expressed as weber (Wb).
- **Magnetic induction (B):** The number of magnetic lines of force (or magnetic flux) passing through unit normal area is defined as magnetic induction.
Magnetic flux = magnetic induction \times normal area
 $\phi = BA \Rightarrow B = \phi/A$
Magnetic induction B is a vector quantity.
It is expressed as weber/metre² or tesla.
- **Intensity of magnetisation.** It is defined as the magnetic dipole moment developed per unit volume or the pole strength developed per unit area of cross-section of the specimen. It is given by

$$I = \frac{M}{V} = \frac{m}{a}$$

Here, V is volume and a is area of cross-section of the specimen. Magnetic induction, intensity of magnetisation and magnetic intensity are related to each other as below :

$$B = \mu_0 (H + I)$$

- Magnetic permeability.** The magnetic permeability of a material is defined as the ratio of the magnetic induction (B) of the material to the strength of magnetising field (H). It is given by

$$\mu = \frac{B}{H}$$

If μ_r is relative permeability of a medium, then

$$\mu_r = \frac{\mu}{\mu_0}$$

- Magnetic susceptibility.** The magnetic susceptibility of a material is defined as the ratio of the intensity of magnetisation (I) and the strength of magnetising field (H). It is given by

$$\chi_m = \frac{I}{H}$$

Also $\mu = \mu_0 (1 + \chi_m)$ so that $\mu_r = 1 + \chi_m$

- The resultant field produced inside a specimen placed in a magnetic field (along the field) is called **magnetic induction B** or **magnetic flux density**.
- On the basis of magnetic properties, different materials have been classified into three categories; **diamagnetic**, **paramagnetic** and **ferromagnetic** substances.

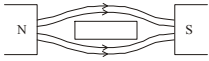
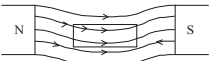
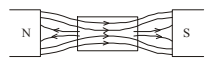
Diamagnetic	Paramagnetic	Ferromagnetic
<ul style="list-style-type: none"> They are weakly repelled by magnet When they are placed in a magnetic field, the lines of force do not prefer to pass through them.  <ul style="list-style-type: none"> Susceptibility (χ_m) has a small negative value. They do not obey Curie's law normally their magnetic properties do not change with temperature 	<ul style="list-style-type: none"> They are weakly attracted by a magnet When they are placed in a magnetic field, most of the lines of force prefer to pass through them  <ul style="list-style-type: none"> Susceptibility (χ_m) has small positive value. They obey Curie's law. Due to rise in temperature they lose magnetic property. 	<ul style="list-style-type: none"> They are strongly attracted by a magnet When they are placed in a magnetic field, the lines of force prefer to pass through them  <ul style="list-style-type: none"> Susceptibility (χ_m) has a large positive value. They obey Curie's law. At a certain temperature i.e. Curie point; ferromagnetic properties disappear and material start behaving as paramagnetic.
<p>Example gold, silver, zinc, lead, mercury, marble, glass, quartz, water e.t.c.</p>	<p>Example Aluminum, chromium, manganese, platinum, antimony, sodium e.t.c.</p>	<p>Example Iron, steel, nickel, cobalt and alloy like alnico etc.</p>

- **Diamagnetic substance** is a substance, a specimen of which when placed in a magnetic field tends to move from stronger to weaker regions; permeability is slightly less than unity.
- **Paramagnetic substance** is a substance, a specimen of which when placed in a magnetic field tends to move from weaker to stronger regions; permeability is slightly greater than unity.
- **Ferromagnetic substances** are substances which can be strongly magnetised; permeability has very large value.
- **Curie temperature.** It is the temperature for a ferromagnetic substance above which, it behaves as a paramagnetic substance.
- **Curie's Law** states that the magnetic susceptibility of a paramagnetic substance varies inversely with its absolute temperature.

$$\chi_m \propto \frac{1}{T} \quad \text{or} \quad \chi_m T = \text{constant}$$

- **Hysteresis.** The lagging of intensity of magnetisation (or magnetic induction) behind the magnetising field, when a magnetic specimen is taken through a cycle of magnetisation, is called hysteresis.

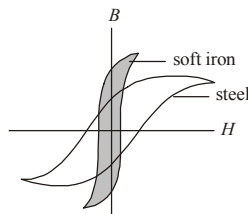

- **Retentivity.** The value of intensity of magnetisation of the magnetic material, when the magnetising field is reduced to zero, is called its retentivity.
- **Coercivity.** The value of the reverse magnetising field, which has to be applied to the magnetic material so as to reduce the residual magnetisation to zero, is called its coercivity.
- **Permanent Magnets :** Steel is common material used to make permanent magnets. It has high residual magnetism. It has high coercivity i.e. hysteresis loop is wider.
- Although area of hysteresis loop for steel is large yet it is of no importance because a permanent magnet is supposed to retain the magnetism and not required to undergo cycle of magnetisation.
- **Electromagnets :** The material for cores of electromagnets should have maximum flux density with comparatively small magnetising field and low hysteresis loss. Soft iron is best suited for electromagnet. The hysteresis loop is thin and long. Due to the small area of hysteresis loop, energy loss is small.

Magnetic moment

- Magnetic moment (M) = ml where m denotes the pole strengths and l denotes magnetic length of the magnet.
- It is a vector quantity. Its direction is along axis of magnet/dipole from south towards north.

- Unit of $M = \text{ampere-metre}^2 = \text{weber} \times \text{metre} = \text{joule/tesla}$.
Dimensions of $M = M^0L^2T^0A^1 = L^2A$.
- About 90% of magnetic moment is due to spin motion of electrons while remaining 10% is due to their orbital motion.
- When a magnet is divided into n equal parts parallel to length, magnetic moment of each part is equal to M/n . Here length of each part is same (l) but due to division of width, the pole strength of each part becomes m/n .

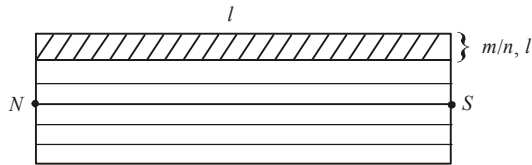

$$M = l \cdot m$$

$$M' = l \times \frac{m}{n} = \frac{M}{n}$$

- When a magnet is divided into n equal parts perpendicular to length, width of each part remains the same but length of each part = l/n .

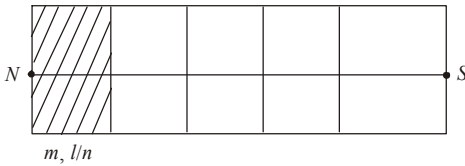

$$M = lm$$

$$M' = \frac{l}{n} \cdot m = \frac{M}{n}$$

- When a current I flows in a coil of effective area A and number of turns N , the magnetic moment of coil $M = NIA$.
 $A = \text{area of coil} = \pi r^2, M = NI\pi r^2$.
- The magnetic moment of a current carrying solenoid = NIA .
 M acts along the axis of solenoid.
- Magnetic moment associated with an electron (or charge) having charge e when it revolves in a circular orbit of radius r with angular speed ω is

$$M = \frac{e\omega r^2}{2} = \frac{er^2}{2} \times \frac{2\pi}{T} = \frac{er^2\pi}{T}$$

- The magnetic moment associated with the electron revolving in the first Bohr orbit is known as Bohr magneton (μ_B).

$$\mu_B = \frac{eh}{4\pi m} = 0.93 \times 10^{-23} \text{ ampere-m}^2$$

- A thin magnetic needle of moment M , length l and pole-strength m is turned into a semicircular arc. Then

$$M' = \frac{2M}{\pi}$$

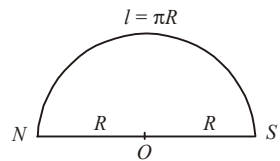

$$M = lm$$

$$M' = 2Rm = \frac{2lm}{\pi} = \frac{2M}{\pi}$$

- A thin magnet of moment M is turned into an arc of 90° . Then new magnetic moment

$$M' = \frac{2\sqrt{2}M}{\pi}$$

$$M = lm$$

$$\Rightarrow M' = (\sqrt{2} \cdot R)m = \sqrt{2} \left(\frac{2l}{\pi} \right) m$$

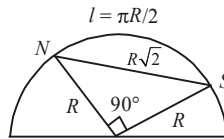

$$\Rightarrow M' = \frac{2\sqrt{2}}{\pi} M$$

Here new length of the magnet turned into an arc = $NS = R\sqrt{2}$

- A thin moment M is turned at midpoint at 90° . Then new magnetic moment $M' = \frac{M}{\sqrt{2}}$.

$$M = lm$$

$$\text{New length (NS)} = \sqrt{2} \cdot \frac{l}{2} = \frac{l}{\sqrt{2}}$$

$$M' = m(NS)$$

$$\Rightarrow M' = \frac{ml}{\sqrt{2}} = \frac{M}{\sqrt{2}}$$

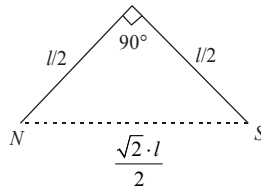

- A thin magnet of moment M is turned into an arc of 60° . Then new magnetic moment M' is given by $M' = 3M/\pi$.

$$M = lm$$

$$\text{New length (NS)} = R$$

$$M' = (NS)m$$

$$\Rightarrow M' = Rm = \frac{3l}{\pi} m$$

$$\Rightarrow M' = \frac{3M}{\pi}$$

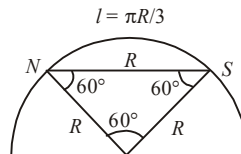

- A thin magnet of moment M is bent at midpoint at angle of 60° . Then new magnetic moment $M' = M/2$.

$$M = lm$$

$$M' = (NS)m$$

$$M' = \frac{lm}{2} = \frac{M}{2}$$

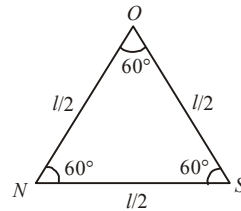

Original magnet NOS is bent at O , the mid point, at 60° . All sides are equal.

- Two magnets of moments M_1 and M_2 are held at 60° to each other. Their south poles are in contact. If magnets are identical with moment M , new magnetic moment $M' = \sqrt{3}M$.

M_2 acts along S_2N_2

M_1 acts along S_1N_1 from south to north.

$$\begin{aligned} \text{Resultant } (M')^2 &= M_1^2 + M_2^2 + 2M_1M_2\cos\theta \\ &= M^2 + M^2 + 2M \times M \times \cos 60^\circ = 2M^2 + M^2 \end{aligned}$$

$$(M')^2 = 3M^2$$

$$M' = \sqrt{3}M$$

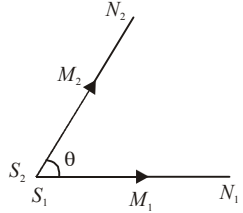

Neutral points

- It is a point in a magnetic field where field due to a magnet (or current in tangent galvanometer) is equal and opposite to B_H . Resultant magnetic field is $(B - B_H) = \text{zero}$.
- A magnetic needle placed at neutral point shall remain in neutral equilibrium. It may point in any direction.

- No line of force passes through neutral point.
 - Neutral point is obtained on elongation of magnetic axis when north pole of magnet points towards south. In line with axis, two neutral points are obtained. They are equidistant from the centre of the magnet.

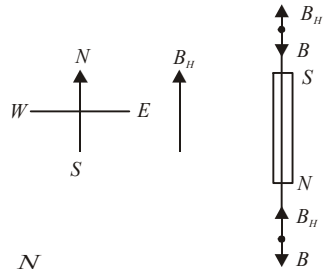

- Two neutral points shall be obtained on equator of the magnet when north pole of the magnet is placed in north. They are equidistant from the centre of magnet.

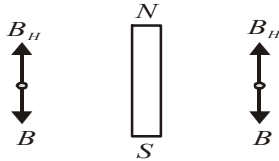

- A neutral point may be obtained at centre of tangent galvanometer if value and direction of current are suitably adjusted in a tangent galvanometer set perpendicular to magnetic meridian.

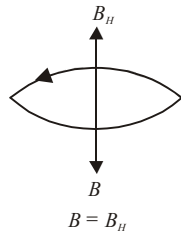

Some salient points about magnetism

- Magnetic moment M for diamagnetic material is almost zero, for paramagnetic material M is very low but for ferromagnetic material M is very high and is in the direction of H .
- Magnetic induction for a material = B
 Magnetic induction for vacuum = B_0
 Then $B < B_0$ for diamagnetic material
 $B > B_0$ for paramagnetic material.
 $B \gg B_0$ for ferromagnetic material.
- Cause of diamagnetism is orbital motion and cause of paramagnetism is spin motion of electrons. Cause of ferromagnetism lies in formation of domains.
- Diamagnetic substances move from stronger magnetic field to weaker field. They are thus repelled in a magnetic field. Paramagnetic substances are feebly attracted and they

move from low field region to high field region. Ferromagnetic substances are strongly attracted and so they move from weaker to stronger region of magnetic field.

(i) In vacuum, $B_0 = \mu_0 H$.

(ii) In medium, $B = \mu H$.

(iii) Resultant field, $B = B_I + B_H = \mu_0 I + \mu_0 H$

$$\Rightarrow B = \mu_0(I + H) = \mu_0 H \left(\frac{I}{H} + 1 \right) = \mu_0 H (\chi_m + 1) = \mu H.$$

- The mutual interaction force between two small magnets of moments M_1 and M_2 is given by

$$F = K \cdot \frac{6M_1 M_2}{d^4} \text{ in end-on position.}$$

Here d denotes the separation between magnets.

(i) For soft iron retentivity/ramnant magnetism is high, coercivity is low, magnetic permeability μ is high and magnetic susceptibility (χ_m) is high.

(ii) For steel, ramnant magnetism is low, coercivity is high, μ is low and χ_m is low.

- All substances exhibit diamagnetism. In paramagnetic and ferromagnetic substances, the diamagnetism is neutralised by the large intrinsic dipole moment of spinning electrons.
- The apparent dip δ' , the real dip δ and the angle with magnetic meridian θ are related as

$$\tan \delta \cos \theta = \tan \delta'.$$

- Magnetic length = $\frac{5}{6}$ × geometric length of magnet .
- The perpendicular bisector of magnetic axis is known as **neutral axis** of magnet. Magnetism at neutral axis is zero and at poles is maximum.

End

electromagnetic induction and alternating current

- Whenever there is a relative motion between a loop (or coil) and a magnet, an emf is induced in the loop (or coil) which is called **induced emf**. This phenomenon is called as electromagnetic induction.
- **Magnetic flux linked with a coil**
 - (i) Flux $\phi = NBA\cos\theta$ where
 B = strength of magnetic field
 N = number of turns in the coil
 A = area of surface
 θ = angle between normal to area and field direction.
 - (ii) When plane of coil is perpendicular to B , *i.e.* $\theta = 0^\circ$, $\phi = NBA$ (maximum value).
 - (iii) When plane of coil is parallel to B , *i.e.* $\theta = 90^\circ$,
 $\phi = 0$ (minimum value)
 - (iv) S.I. unit of ϕ = weber
c.g.s unit of ϕ = maxwell
1 weber = 10^8 maxwell.
 - (v) Dimensional formula of magnetic flux
 $[\phi] = [ML^2T^{-2}A^{-1}]$.
- **Faraday's laws of electromagnetic induction**
 - (i) Whenever magnetic flux linked with a circuit (a loop of wire or a coil or an electric circuit in general) changes, induced emf is produced.
 - (ii) The induced emf lasts as long as the change in the magnetic flux continues.
 - (iii) The magnitude of induced emf is directly proportional to the rate of change of the magnetic flux linked with the circuit.

$$\varepsilon = -\frac{Nd\phi}{dt}$$
where N is turns in a coil.
- By Faraday's second law of induction, $\varepsilon = -d\phi/dt$
Apply it to the coil.
Induced e.m.f. ε depends on rate of change of magnetic flux linked with the coil.
Flux $\phi = NBA\cos\theta$ where
 B = strength of magnetic field
 N = number of turns in the coil
 A = area of surface

θ = angle between normal to area and field direction.

$$\varepsilon = -\frac{d}{dt}(NBA\cos\omega t) \text{ where } \theta = \omega t$$

Induced e.m.f. ε depends on N , B , A and ω .

- **Lenz's Rule**

States that the induced current produced in a circuit always flows in such a direction that it opposes the change or the cause that produce it.

- **Fleming's right hand rule**

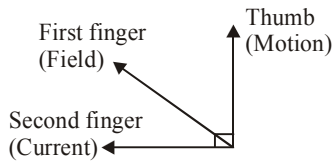

- **Motional E.M.F.**

When a conductor of length l moves with a velocity v in a magnetic field B , so that magnetic field is perpendicular to both the length of the conductor and its direction of motion, the magnetic Lorentz force on the conductor gives rise to e.m.f. Mathematically, $\varepsilon = Blv$.

- **Eddy currents/Focault's currents**

Currents induced in conductor, when placed in a changing magnetic field are also known as **Focault's currents**.

- **Self inductance**

The phenomenon, according to which an opposing induced emf is produced in a coil as a result of change in current or magnetic flux linked with the coil is called self-inductance.

- **Coefficient of self induction or self inductance L**

$$\Rightarrow \phi = LI$$

$$\Rightarrow \varepsilon = -L \frac{dI}{dt}$$

- **Self inductance/coefficient of self induction**

(i) The self inductance L depends on geometry of coil or solenoid and the permeability of the core material of the coil or solenoid.

(ii) Unit of L = henry.

(iii) Dimensions of inductance = $[ML^2T^{-2}A^{-2}]$

(iv) For a small circular coil, $L = \frac{\mu_0\mu_r N^2 \pi r^2}{2}$

(v) For a solenoid, $L = \frac{\mu_0\mu_r N^2 A}{l}$.

(vi) For two coils connected in series when

– Current flows in same direction in both,

$$L = L_1 + L_2 + 2M$$

– When currents flow in two coils in opposite directions

$$L = L_1 + L_2 - 2M$$

If $M = 0$, $L = L_1 + L_2$

(vii) For two coils connected in parallel

$$\frac{1}{L} = \frac{1}{L_1 + M} + \frac{1}{L_2 + M} \Rightarrow L = \frac{(L_1 + M)(L_2 + M)}{L_1 + L_2 + 2M}$$

If $M = 0$, $L = \frac{L_1 L_2}{L_1 + L_2}$

(viii) Self inductance of a toroid, $L = \frac{\mu_0 N^2 A}{2\pi r}$.

• **Mutual inductance (M)**

(i) Mutual inductance of two coils is numerically equal to magnetic flux linked with one coil, when a unit current flows through the neighbouring coil.

$$\Rightarrow \phi = MI$$

$$\varepsilon = -M \frac{dI}{dt}$$

(ii) For two long co-axial solenoids, each of length l , common area of cross-section A wound on air core,

$$M = \frac{\mu_0 N_1 N_2 A}{l}$$

(iii) For two coupled coils, $M = K\sqrt{L_1 L_2}$ where K denotes the coefficient of coupling between the coils.

(iv) If $K = 1$, the coils are said to be tightly coupled such that magnetic flux produced in primary is fully linked with the secondary.

$$M = \sqrt{L_1 L_2} = \text{maximum value of } M.$$

• **Energy stored in an inductor**

$$\Rightarrow E = \frac{1}{2} LI^2$$

• **Induced emf due to rotation and translation**

(i) A conducting rod rotates in a perpendicular magnetic field

$$\varepsilon = -\frac{B\omega L^2}{2} = -BAf \quad \text{where } f = \text{frequency of rotation}$$

$$A = \text{area swept by rotating rod} = \pi L^2$$

$$L = \text{length of rod, } \omega = \text{angular/rotational speed}$$

(ii) A disc rotates in a perpendicular magnetic field

$$\varepsilon = -B\pi r^2 \cdot f = -\frac{Br^2\omega}{2} = -BAf, \quad \text{where}$$

$$A = \pi r^2 = \text{area of disc, } \omega = \text{angular speed of disc}$$

(iii) A rectangular coil moves linearly in a field when coil moves with constant velocity in a uniform magnetic field, flux and induced emf will be zero.

(iv) When a coil is displaced in a field B , $\varepsilon = -Bvl$ where v = velocity of coil.

(v) A rod moves, at an angle θ with the direction of magnetic field, with velocity

$$\varepsilon = -Blv\sin\theta$$

$$\varepsilon = -Blv \quad \text{when rod moves along normal to the field.}$$

• **An emf is induced in the following cases:**

- (i) When a train moves horizontally in any direction.
- (ii) When an aeroplane flies horizontally.
- (iii) When a conductor falls freely in east-west direction.
- (iv) When an aeroplane takes off or lands with its wings in east-west direction.
- (v) The plane of orbit of a metallic satellite is inclined to the equatorial plane at any angle.
- (vi) When a magnet is moved with respect to a coil, an emf is induced in the coil.
- (vii) When a current carrying coil is moved with respect to a stationary coil, a current is induced in the stationary coil.
- (viii) When strength of current flowing in a coil is increased or decreased induced current is developed in the coil in same or opposite direction.

Growth and decay of current

• **Growth of current in inductive circuit**

- (i) The value of current at any instant of time t is given by

$$I = I_0(1 - e^{-Rt/L}) \quad \text{where}$$

I_0 = maximum/final current

R = total resistance of circuit

- (ii) If $t = L/R$

$$I = 0.63I_0 = 63\% I_0$$

$\tau = L/R$ = time constant of circuit.

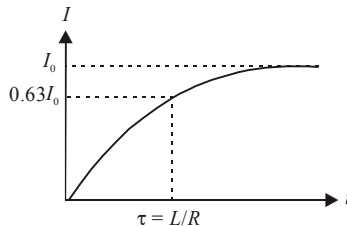

- (iii) Inductance acts as electrical inertia. It opposes growth of current as well as decay of current.

• **Decay of current in inductive circuit**

- (i) During decay, current at any instant of time is given by

$$I = I_0 \cdot e^{-Rt/L}$$

- (ii) If $t = L/R = \tau$ = time constant of circuit,

$$I = I_0/e = 37\% I_0.$$

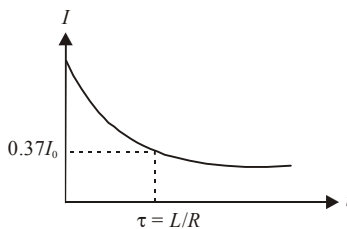

Charge and discharge of a capacitor

• **Charge of condenser**

- (i) *Instantaneous charge* : When the key K_1 is closed, the capacitor gets charged. Finite time is taken in the charging process.

Instantaneous charge = q

$$\therefore q = q_0 [1 - e^{-(t/RC)}]$$

where q_0 = maximum final value of charge at $t = \text{infinity}$ and R = resistance of whole circuit.

The equation reveals that q increases exponentially with increase of time.

- (ii) If $t = RC = \tau$ = time constant.

$$q = q_0 [1 - e^{-(RC/RC)}] = q_0 \left[1 - \frac{1}{e} \right]$$

$$\text{or } q = q_0(1 - 0.37) = 0.63q_0$$

$$\text{or } q = 63\% \text{ of } q_0.$$

Time $\tau = RC$ is known as time-constant.

- (iii) Dimensions of $RC = [T] = [M^0L^0T^1]$
- (iv) Potential difference across condenser plates = V
 $\therefore V = V_0 [1 - e^{-(t/RC)}]$
- (v) $I = I_0 [e^{-(t/RC)}]$.
 If $t = RC$, then transient current I is given by
 $I = I_0/e = 0.37 I_0$
 or $I = 37\% \text{ of } I_0$.

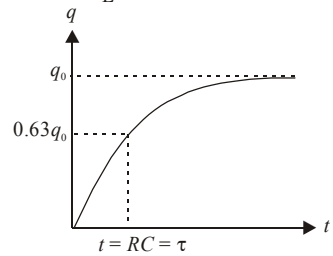
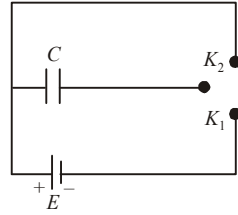

• **Discharge of condenser**

If key K_1 is opened and key K_2 is closed, then the capacitor gets discharged.

- (i) *Instantaneous charge* : $q = q_0 e^{-(t/RC)}$
 The charge decays exponentially.

- (ii) Time constant = τ

$$\text{If } t = RC = \tau$$

$$q = q_0/e = 0.37 q_0 = 37\% \text{ of } q_0.$$

The time constant is that time during which the charge on capacitor plates, during discharge process, decays to 37% of its maximum value.

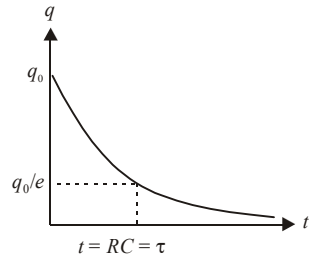

- (iii) The dimensions of RC are those of time *i.e.* $M^0L^0T^1$.
- (iv) The potential difference across the capacitor plates at any instant of time is given by
 $V = V_0 e^{-(t/RC)}$
- (v) Transient current I at any instant of time is given by $I = -I_0 e^{-(t/RC)}$
 The current in the circuit decays exponentially but its direction is opposite to that of charging current.

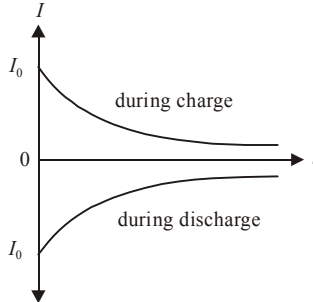

Alternating current and alternating e.m.f

- **Instantaneous values (I) and (E)**

$$I = I_0 \sin \omega t \quad \text{or} \quad I = I_0 \cos \omega t$$

$$E = E_0 \sin \omega t \quad \text{or} \quad E = E_0 \cos \omega t \quad \text{where}$$

I, E = instantaneous values of current and e.m.f.
 I_0, E_0 = peak values of current and e.m.f.
 ω = angular velocity
 $\omega = 2\pi f$ where f denotes frequency.
 $\omega = 2\pi/T$ where T denotes periodic time.

- **Mean or average values**

(i) In first half-cycle,

$$I_m = \frac{2}{\pi} I_0 \quad \text{and} \quad E_m = \frac{2}{\pi} E_0 \Rightarrow I_m = 0.637 I_0, E_m = 0.637 E_0$$

(ii) In second half-cycle,

$$I_m = -\frac{2}{\pi} I_0 = -0.637 I_0, E_m = -\frac{2}{\pi} E_0 = -0.637 E_0$$

(iii) Over a complete cycle,

$$I_m = 0 \quad \text{and} \quad E_m = 0.$$

- **Root mean square (RMS = r.m.s.) value**

(i) RMS value is also known as virtual value or effective value.

(ii) All A.C. instruments measure virtual value.

$$(iii) I_v = \frac{I_0}{\sqrt{2}} = 0.707 I_0, E_v = \frac{E_0}{\sqrt{2}} = 0.707 E_0$$

$$(iv) \text{Form factor of A.C. } (K) = \frac{I_v}{I_m} = \frac{0.707 I_0}{0.637 I_0} = 1.11$$

- **Reactance**

(i) It is the opposition offered to A.C. by a coil of inductance L or by a capacitor of capacitance C .

(ii) Reactance arises on account of induction effects.

- **Inductive reactance (X_L)**

$$(i) X_L = \omega L = 2\pi f L = \frac{2\pi}{T} L$$

(ii) Alternating current lags behind the alternating e.m.f. applied to a pure inductor by phase angle of 90° .

(iii) For direct current (d.c.), frequency $f = 0$.

$$\therefore X_L = \text{zero.}$$

An inductor thus behaves like a perfect conductor for d.c.

(iv) For a.c., higher the frequency f , greater is the inductive reactance.

(v) Average power over one full cycle of a.c.

$$P_{av} = E_v I_v \cos\theta = E_v I_v \cos 90^\circ = \text{zero.}$$

(vi) Energy stored in inductor = $\frac{1}{2}LI_0^2$.

(vii) **Choke coil:** It is a pure inductance coil. Since power consumed in it is zero, the current in choke coil is known as wattless current.

$$\text{(viii) Susceptance} = \frac{1}{\text{reactance}} \Rightarrow S_L = \frac{1}{X_L} = \frac{1}{\omega L}$$

It is measured in siemen or $(\text{ohm})^{-1}$.

• **Capacitive reactance (X_C)**

$$\text{(i) } X_C = \frac{1}{\omega C} = \frac{1}{2\pi f C}$$

(ii) Alternating current leads the alternating e.m.f. in a pure capacitor by phase angle of 90° .

(iii) For d.c., $X_C = \frac{1}{2\pi f C} = \frac{1}{0} = \infty$.

A condenser blocks d.c.

(iv) For a.c., higher the frequency f , lower is the capacitive reactance.

(v) Average power or true power over one full cycle of a.c.

$$P_{av} = E_v I_v \cos\theta = E_v I_v \cos 90^\circ = \text{zero.}$$

(vi) Energy stored in a capacitor = $\frac{1}{2}CV^2 = \frac{QV}{2} = \frac{Q^2}{2C}$

(vii) Susceptance is reciprocal of reactance.

$$S_C = \frac{1}{X_C} = \omega C.$$

Susceptance is measured in $(\text{ohm})^{-1}$ or siemen.

• **Impedance**

(i) The total effective opposition in LCR circuit is called impedance (Z).

$$\text{(ii) } Z = \sqrt{R^2 + (X_L - X_C)^2}$$

$$\tan \phi = \frac{X_L - X_C}{R}$$

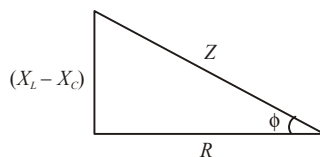

ϕ = angle by which e.m.f. leads the current in LCR circuit.

(iii) Admittance (K)

Reciprocal of impedance is called admittance. $K = \frac{1}{Z} = \frac{1}{\sqrt{R^2 + (X_L - X_C)^2}}$

It is measured in $(\text{ohm})^{-1}$ or siemen.

- **Power in a.c. circuit**

(i) Instantaneous power = $P_{in} = EI$

$$P_{in} = (E_0 \sin \omega t) I_0 \sin(\omega t \pm \theta)$$

(ii) Average power or true power

$$P_{av} \text{ or } \langle P \rangle = E_v I_v \cos \theta = \frac{E_0 I_0}{2} \cos \theta$$

(iii) Apparent power (P_v)

$$P_v = E_v \cdot I_v = \frac{E_0 I_0}{2}$$

It is equal to maximum value of average power.

- **Power factor**

(i) Power factor of an a.c. circuit = $\frac{\text{true power}}{\text{apparent power}}$

\Rightarrow Power factor = $\cos \theta = R/Z$.

(ii) It is a unitless and dimensionless quantity.

(iii) Its value lies between 0 and 1.

(iv) Power lost in the circuit is the meaning of power factor of the circuit.

- **Purely resistive circuit**

(i) $E = E_0 \sin \omega t$

(ii) $I = I_0 \sin \omega t$

(iii) Phase difference between I and E is zero.

(iv) Peak current $I_0 = E_0/R$

(v) Average power = true power = $E_v I_v$

(v) Power factor = $\cos \theta = \cos 0 = 1$.

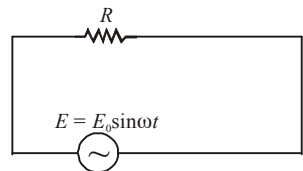

- **Pure inductive circuit**

(i) $E = E_0 \sin \omega t$

(ii) $I = I_0 \sin \left(\omega t - \frac{\pi}{2} \right)$

(iii) Current lags behind e.m.f. by $\pi/2$ or e.m.f. leads over current by $\pi/2$

(iv) Reactance $X_L = \omega L = 2\pi f L$

(v) Peak current $I_0 = E_0/X_L$

(vi) Average power = zero.

(vii) Power factor = $\cos \theta = \cos 90^\circ = \text{zero}$.

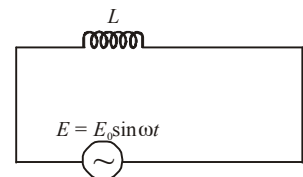

- **Pure capacitive circuit**

(i) $E = E_0 \sin \omega t$

(ii) $I = I_0 \sin \left(\omega t + \frac{\pi}{2} \right)$

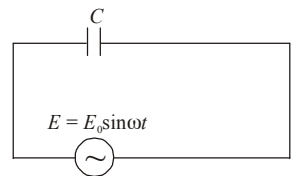

(iii) Current leads the e.m.f. by $\pi/2$ or e.m.f. lags behind the current by $\pi/2$

(iv) Reactance = $X_C = \frac{1}{\omega C} = \frac{1}{2\pi f C}$

(v) Peak current = $I_0 = E_0/X_C$

(vi) Average power = zero

(vii) Power factor = $\cos\theta = \cos 90^\circ = \text{zero}$.

• **L-R circuit**

(i) Equations of E and I

$E = E_0 \sin \omega t$

$I = I_0 \sin(\omega t - \theta)$

Current I lags behind the applied e.m.f. E by θ .

It means that the e.m.f. leads over current by θ .

Equations can also be represented as

$E = E_0 \sin(\omega t + \theta)$ and

$I = I_0 \sin \omega t$.

(ii) Resultant voltage

$$\begin{aligned} (V_0)_{LR}^2 &= (V_0)_L^2 + (V_0)_R^2 \\ &= I_0^2 (R^2 + X_L^2) \end{aligned}$$

or, $(V_0)_{LR} = I_0 \sqrt{R^2 + \omega^2 L^2}$

(iii) Power factor ($\cos\theta$) = $\frac{R}{\sqrt{R^2 + \omega^2 L^2}} = \frac{R}{Z_{LR}}$

(iv) Average power $\langle P \rangle$

$\langle P \rangle = E_{\text{rms}} I_{\text{rms}} \cos\theta$.

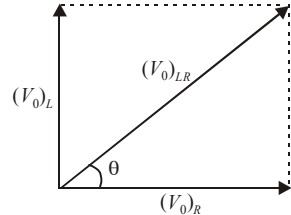
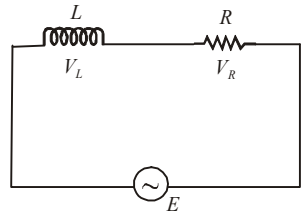

• **R-C circuit**

(i) Equations of E and I

$E = E_0 \sin \omega t$

$I = I_0 \sin(\omega t + \theta)$

or $E = E_0 \sin(\omega t - \theta)$,

$I = I_0 \sin \omega t$.

emf E lags behind the current I by θ

or current I leads over e.m.f. by θ

(ii) Resultant voltage $(V_0)_{CR}$

$$\begin{aligned} (V_0)_{CR}^2 &= (V_0)_R^2 + (V_0)_C^2 \\ &= I_0^2 (R^2 + X_C^2) \end{aligned}$$

or $(V_0)_{CR} = I_0 \sqrt{R^2 + \frac{1}{\omega^2 C^2}}$

(iii) Power factor ($\cos\theta$)

$$\cos\theta = \frac{R}{Z_{CR}} = \frac{R}{\sqrt{R^2 + X_C^2}}$$

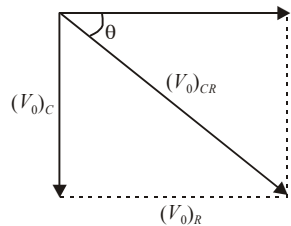
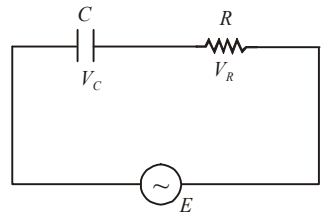

(iv) Average power, $\langle P \rangle$

$$\langle P \rangle = \frac{E_{\text{rms}} I_{\text{rms}} R}{Z_{CR}}$$

• **L-C circuit**

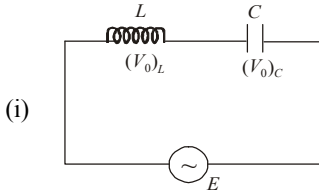

(ii) Resultant voltage

$$(V_0)_{LC} = (V_0)_L \sim (V_0)_C$$

$$= I_0(X_L \sim X_C) = I_0\left(\omega L \sim \frac{1}{\omega C}\right)$$

$$= I_0 \left[2\pi f L \sim \frac{1}{2\pi f C} \right]$$

• **Phase relations**

- (i) The phase difference between V_L and V_C is 180° *i.e.* they are in mutually opposite phase.
- (ii) V_L leads I by a phase angle of 90° .
- (iii) V_C lags behind I by a phase angle of 90° .
- (iv) I will lead E by 90° if $X_C > X_L$.
- (v) I will lag behind E by 90° if $X_C < X_L$.

• **Impedance or reactance**

(i) $Z = X_L \sim X_C$

(ii) $Z = L\omega \sim \frac{1}{C\omega}$

(iii) $Z = 2\pi f L \sim \frac{1}{2\pi f C}$

(iv) If $X_L > X_C$, then $Z = X_L - X_C = \omega L - \frac{1}{\omega C}$

(v) If $X_L < X_C$, then $Z = X_C - X_L = \frac{1}{\omega C} - \omega L$

(vi) If $X_L = X_C$, then $Z = 0$.

• **LCR series circuit**

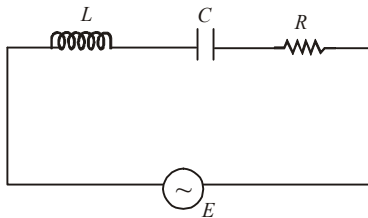

- (i) The alternating e.m.f. leads/lags behind the current by a phase angle ϕ given by

$$\tan \phi = \frac{\omega L - 1/\omega C}{R}$$

- (ii) The e.m.f. leads the current, if $\omega L > 1/\omega C$ and it lags behind the current, if $\omega L < 1/\omega C$.

- (iii) Impedance of LCR -circuit, $Z = \sqrt{R^2 + (\omega L - 1/\omega C)^2}$

- (iv) Power factor, $\cos \phi = \frac{R}{\sqrt{R^2 + (\omega L - \frac{1}{\omega C})^2}} = \frac{R}{Z}$

• **Series resonant circuit**

- (i) L , C and R are connected in series.

- (ii) Condition of resonance is $X_L = X_C$.

$$\Rightarrow L\omega = \frac{1}{C\omega} \Rightarrow LC\omega^2 = 1 \Rightarrow \omega = \frac{1}{\sqrt{LC}}$$

$$\Rightarrow 2\pi f = \frac{1}{\sqrt{LC}} \Rightarrow f = \frac{1}{2\pi\sqrt{LC}}$$

This means that frequency of a.c. applied to circuit becomes equal to natural frequency of energy oscillations in the circuit.

- (iii) $Z = R$ at resonance

$$I_0 = \frac{E_0}{2} = \frac{E_0}{R} = \text{circuit admits maximum current.}$$

The following figures indicate variation of Z and current with frequency.

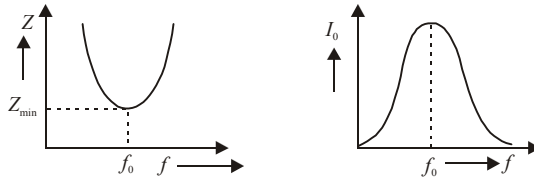

- (iv) *Acceptor circuit* : Series resonance circuit is known as acceptor circuit.

- (v) *Sharpness at resonance or Q-factor* : Q should be higher for sharper resonance.

$$Q = \frac{1}{R} \sqrt{\frac{L}{C}}$$

• **Parallel resonant circuit**

- (i) It is known as rejector circuit.

- (ii) L and C are connected in parallel with each other.

- (iii) At resonance, $X_L = X_C$

Impedance Z is maximum.

Current I_0 is minimum.

The figures indicate the variations.

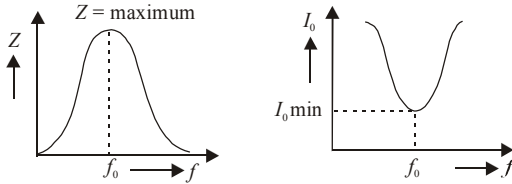

Transformer

- It is based on the phenomenon of mutual induction between two coils known as the primary coil and the secondary coil.
- It is used for transmission of a.c. over long distances at high voltages. The energy losses and cost of transmission are reduced by this device.
- **Step-up transformer:**
 - (i) The output voltage E_s across secondary coil is greater than input voltage E_p in primary coil.
 - (ii) But $I_s < I_p$.
 - (iii) $N_s > N_p$ where N denotes the number of turns in the coils.

$$(iv) \frac{E_s}{E_p} = \frac{I_p}{I_s} = \frac{N_s}{N_p} > 1.$$

- **Step-down transformer**

- (i) The output voltage $E_s < E_p$
- (ii) The output current $I_s > I_p$
- (iii) The number of turns $N_s < N_p$

$$(iv) \frac{E_s}{E_p} = \frac{I_p}{I_s} = \frac{N_s}{N_p} < 1.$$

- **Transformation ratio (K)**

$$K = \frac{E_s}{E_p} = \frac{I_p}{I_s} = \frac{N_s}{N_p}.$$

- Efficiency of transformer = $\frac{\text{output power}}{\text{input power}}$

$$\eta = \frac{E_s I_s}{E_p I_p}$$

Energy losses in transformer

- For an ideal transformer,
output power = input power
 $E_s I_s = E_p I_p$

$$\frac{E_s}{E_p} = \frac{I_p}{I_s} = \frac{N_s}{N_p}$$

But in practice, these are losses.

Output power < input power.

The losses are discussed along with remedy.

- **Copper losses**

(i) Windings are made of copper wire. Energy is lost as heat in resistance of copper wire.

(ii) It is reduced by use of thick wires of copper.

- **Iron losses/eddy current losses**

(i) Energy is lost due to eddy currents in the core of transformer.

(ii) It is reduced by using laminated soft iron core.

- **Flux leakage**

(i) Some magnetic flux leaks in air between primary and secondary coils.

(ii) It is reduced by winding the secondary coil over a primary coil using insulator between them.

- **Hysteresis loss**

(i) The core is magnetised and demagnetised and energy is lost as heat.

(ii) It is reduced by using soft iron core.

Various material points about transformer

- There is a phase difference of π radian between E_s and E_p . Obviously they are in opposite phases.
- Transformer, a device based on mutual induction, converts magnetic energy into electrical energy.
- Transformer does not amplify power as a vacuum tube (triode) does.
- Law of conservation of energy holds good for a transformer.
- It does not operate on d.c. or direct voltages. It operates only on alternating voltages at input as well as at output.
- Frequency of output voltage across secondary coil is same as that of input voltage across primary coil.

- Efficiency = $\frac{\text{Output power}}{\text{Input power}} = \frac{\text{power in secondary}}{\text{power in primary}}$

Power available in secondary can never be greater than power fed in primary.

At the most, efficiency = 1 = 100%.

Generally, efficiency ranges from 70% to 90%.

Some salient features about a.c., transformer and inductance

- The dimensions of L/R , RC and \sqrt{LC} are the dimensions of time. Their reciprocal have dimensions of frequency.
- Form factor of a.c. is $K = \frac{I_v}{I_m} = \frac{0.707I_0}{0.637I_0} = 1.11$

- The direction of induced e.m.f. depends on
 - (i) direction of magnetic flux
 - (ii) rate of change of magnetic flux *i.e.* $d\phi/dt$ is increasing or decreasing
- An induction coil generates high voltages of the order of 10^5 volts from a battery. It is based on the phenomenon of mutual induction.
- A choke coil is a pure inductor. Average power consumed per cycle is zero in a choke coil.
- For reducing low frequency a.c., choke coil with laminated soft iron cores are used.
- For reducing high frequency a.c., air cored chokes are used.
- A d.c. motor converts d.c. energy from a battery into mechanical energy of rotation.
- A motor starter is a variable resistance connected in series with the motor coil. It protects the motor from damage when it is switched on.
- A d.c. dynamo/generator produces d.c. energy from mechanical energy of rotation of a coil.
- An a.c. dynamo/generator produces a.c. energy from mechanical energy of rotation of a coil.
- **Effective current**
 - (i) The component of a.c. which remains in phase with the alternating e.m.f. is defined as the effective current.
 - (ii) The power lost due to effective current is given by $E_v I_v \cos\theta$.
 - (iii) The peak value of effective current is $I_0 \cos\theta$. Its r.m.s. value is $\frac{I_0}{\sqrt{2}} \cos\theta$.
- Lenz's law is based on the law of conservation of energy.
- $\text{henry} = \frac{\text{volt}}{\text{amp/sec}} = \frac{\text{volt} \times \text{sec}}{\text{amp}} = \text{ohm} \times \text{sec}$
- If a solenoid is placed partly in different media, then

$$M = \frac{\mu_0 N_1 N_2}{l} (\mu_1 A_1 + \mu_2 A_2 + \dots)$$
- **Reciprocity relation** : Mutual inductance M depends on two coils. It does not matter which one of them acts as the primary or the secondary coil. The relation $M = \frac{\mu_0 A N_1 N_2}{l}$ for a solenoid is known as reciprocity relation.



End

electromagnetic waves

- **Electromagnetic radiation** is the radiation in which associated electric and magnetic field oscillations are propagated through space. The electric and magnetic fields are at right angle to each other and to the direction of propagation.
- Propagation of electromagnetic wave through space is fully described in terms of wave theory but interaction with matter depends on quantum theory.
- Maxwell showed that the changing electric field intensity is equivalent to a current through the capacitor. This current through the capacitor is known as displacement current.

$$I_d = \frac{\epsilon_0 d\phi_E}{dt}$$

- Maxwell was first to provide the mathematical structure of the laws of electromagnetism.
- The basic principle of electromagnetism can be formulated in terms of four fundamental equations called Maxwell's equations.
- Four Maxwell's equations are – Gauss's law for electrostatics

$$\oiint \vec{E} \cdot d\vec{S} = \frac{q}{\epsilon_0}$$

which describes the charge and the electric field.

– Gauss's law for magnetism

$$\oiint \vec{B} \cdot d\vec{S} = 0$$

which describes the magnetic field.

– Faraday's law of induction

$$\oint \vec{E} \cdot d\vec{l} = \frac{-d\phi_B}{dt}$$

which describes the electrical effect of a changing magnetic field.

– Ampere's law of induction (as extended by Maxwell)

$$\oint \vec{B} \cdot d\vec{l} = \mu_0 i + \mu_0 \epsilon_0 \frac{d\phi_E}{dt}$$

which describes the magnetic effect of a current or a changing electric field.

- Maxwell's equations apply to electric and magnetic fields in vacuum. They may also be generalised to include fields in matter.
- Hertz was first to demonstrate the production of electromagnetic waves in the laboratory which is based on principle that a vibrating charge radiates electromagnetic waves.
- Hertz produced electromagnetic waves, with the aid of oscillating circuits. To receive and detect these waves, the other circuits, tuned to same frequency, were used.

- The frequency of oscillation, $\nu = 1/2\pi\sqrt{LC}$.
- Hertz from his experiment produced standing electromagnetic waves and measured the distance between adjacent nodes, to measure the wavelength. Knowing the frequency of his resonators, he then found the velocity of the wave from the fundamental wave equation $c = \nu \lambda$ and verified that it was the same as that of light, as given by Maxwell.
- The unit of frequency, one cycle per second is named one hertz (1 Hz) in honour of Hertz.
- The plane progressive electromagnetic wave has the following characteristics.
 - The electric vector, the magnetic vector and the direction of propagation are mutually perpendicular to each other. i.e. the electromagnetic wave is a transverse wave.
 - The equation of plane progressive electromagnetic wave can be written as

$$E = E_0 \sin \omega \left(t - \frac{x}{c} \right), \quad B = B_0 \sin \omega \left(t - \frac{x}{c} \right), \quad \text{where } \omega = 2\pi \nu.$$

This shows that both the electric and magnetic fields oscillate with the same frequency ν and there is no phase difference between them.

- Both these fields have varying time and space and have the same frequency.
- **Velocity** of electromagnetic waves in free space is given by,

$$c = \frac{1}{\sqrt{\mu_0 \epsilon_0}} = 3 \times 10^8 \text{ m/s}.$$

- The instantaneous magnitude of the electric and magnetic field vectors in electromagnetic wave are related as -

$$\frac{|E|}{|B|} = c \quad \text{or} \quad E = Bc.$$

- In a medium of refractive index n , the velocity v of an electromagnetic wave is given by

$$v = \frac{c}{n} = \frac{1}{n} \cdot \frac{1}{\sqrt{\mu_0 \epsilon_0}}. \quad \text{Also, } v = \frac{1}{\sqrt{\mu \epsilon}}. \quad \text{So that } n = \sqrt{\frac{\mu \epsilon}{\mu_0 \epsilon_0}}.$$

- The energy is equally shared between electric field and magnetic field vectors of electromagnetic wave. Therefore the energy density of the electric field, $u_E = \frac{1}{2} \epsilon_0 E^2$;

$$\text{the energy density of magnetic field, } u_B = \frac{1}{2} \frac{B^2}{\mu_0}.$$

- Average energy density of the electric field, $\langle u_E \rangle = \frac{1}{4} \epsilon_0 E_0^2$ and average energy density of the magnetic field $\langle u_B \rangle = \frac{1}{4} \mu_0 B_0^2 = \frac{1}{4} \epsilon_0 E_0^2$.

- Average energy density of electromagnetic wave is

$$\langle u \rangle = \frac{1}{2} \epsilon_0 E_0^2$$

- **Intensity** of electromagnetic wave is defined as energy crossing per unit area per unit time perpendicular to the directions of propagation of electromagnetic wave. The intensity I is given by the relation

$$I = \langle u \rangle c = \frac{1}{2} \epsilon_0 E_0^2 c.$$

- The electromagnetic wave also carries linear momentum with it. The linear momentum carried by the portion of wave having energy U is given by $p = U/c$.
- If the electromagnetic wave incident on a material surface is completely absorbed, it delivers energy U and momentum $p = U/c$ to the surface.
- If the incident wave is totally reflected from the surface, the momentum delivered to the surface is $U/c - (-U/c) = 2U/c$. It follows that the electromagnetic wave incident on a surface exert a force on the surface.
- According to Maxwell, when a charged particle is accelerated it produces electromagnetic wave. The total radiant flux at any instant is given by

$$P = q^2 a^2 / (6\pi\epsilon_0 c^3)$$

where q is the charge on the particle, and a is its instantaneous acceleration.

- The electromagnetic wave is emitted when an electron orbiting in higher stationary orbit of atom jumps to one of the lower stationary orbit of that atom.
- The electromagnetic waves are also produced when fast moving electrons are suddenly stopped by the metal of high atomic number.
- The total energy flowing perpendicularly per second per unit area in to the surface in free space is called a **poynting vector** \vec{S} ,

$$\vec{S} = c^2 \epsilon_0 (\vec{E} \times \vec{B}) = \frac{\vec{E} \times \vec{B}}{\mu_0}$$

The S.I. unit of S is **watt/m²**.

- The rate of energy transfer for electromagnetic wave is proportional to the product of the electric and magnetic field strength, *i.e.* to the surface integral of the poynting vector formed by the component of the field in the plane of the surface.
- The average value of poynting vector (\vec{S}) over a convenient time interval in the propagations of electromagnetic wave is known as radiant flux density. When energy of electromagnetic wave is incident on a surface, the flux density is called **intensity of wave** (denoted by I). Thus $I = S$.
- The orderly distributions of electromagnetic radiations according to their wavelength or frequency is called the **electromagnetic spectrum**.
- **Radiowaves** have wavelength longer than 1 m. They can be produced by electron oscillating in wires of electric circuits and antennas can be used to transmit or receive radiowaves that carry AM or FM radio and TV signals.
- **Microwave** can be regarded as short radio waves, with typical wavelength in the range 1 mm to 30 cm. They are commonly produced by oscillating electric circuits, as in the case of microwave oven.
- **Infrared radiation**, which has wavelengths longer than the visible (from 0.7 μm to about 1 μm), is commonly emitted by atoms or molecules when they change their vibration motion or vibration with rotation. Infrared radiation is sometimes called heat radiation.
- **Visible light** the most familiar form of electromagnetic wave, is that part of the spectrum the human eye can detect. The limits of wavelength of the visible region are from 430 nm (violet) to 740 nm (red).

- **Ultraviolet light** covers wavelengths ranging from 4.3×10^{-7} m (430 nm) down to 6×10^{-10} (0.6 nm).
Ultraviolet rays can be produced by electrons in atoms as well as by thermal sources such as the sun.
- **X-rays** - typical wavelength in the range of about 10^{-18} nm to 10^{-13} m (10^{-4} nm) can be produced with discrete wavelength in atoms by transitions involving the most tightly bound electrons and they can also be produced in continuous range of wavelengths when charged particles such as electron are decelerated.
- **Gamma rays** which have shortest wavelengths in the electromagnetic spectrum (less than 10 pm), are emitted in the decays of many radioactive nuclei and certain elementary particles.
- The radiowaves can travel from the transmitting antenna to the receiving antenna by the following ways:
 - (i) **Ground wave propagation:**
The lower frequency [500 kHz to 1600 kHz] broadcast service use the surface wave propagation. These waves travel close to the surface of the earth. The electrical conductivity of the earth plays an important role in deciding the propagational characteristics of these waves.
 - (ii) **Sky wave propagation:**
The radiowaves which reach the receiving antenna as a result of reflection from the ionosphere layers are called sky waves.
Frequency range from 1500 kHz to 40 MHz is used in sky wave propagation.
Due to mutual reflections between the earth and the ionosphere, long distance transmission is possible by the sky waves.
 - (iii) **Space wave propagation :**
The electromagnetic waves which travel directly from the transmitting antenna to the receiving antenna, without being influenced by the earth are called space wave. Microwaves *i.e.* T.V. and radar waves follow this mode of propagation.
- In the day time, the radiations from the sun reach the earth. At night, the earth's atmosphere prevents the infrared radiations of earth from passing through it and thus helps in keeping the earth's surface warm. This phenomenon is called **green house effect**.
- Electromagnetic waves of frequency less than 30 MHz form amplitude modulated range.
- The electromagnetic waves of frequencies between 80 MHz to 200 MHz form frequency modulated band.
- Height of transmitting antenna (h) related with the relation, $d = \sqrt{2hR}$
where d is the radius of the circle on the surface of earth within which the transmitted signal from the transmitting antenna can be received and R is the radius of earth.
Area covered = $\pi d^2 = \pi(2hR)$
Population covered = (area covered) \times (population density)

 A decorative logo consisting of a stylized, swirling line that forms a shape resembling the word 'End' in a cursive font.

ray optics

- Ray optics is based on the assumption that light travels along straight lines.
- Sources of light are of three types: thermal sources, gas discharge sources and luminescent sources.
- Photometry is a branch of ray optics which deals with the measurement of light energy.
- The amount of visible light energy emitted per second from the source is called luminous flux (Φ) of a source of light. The S.I. unit of luminous flux is lumen.
- The luminous flux emitted per unit solid angle in any direction is known as luminous intensity (I) of a light source. S.I. unit of luminous intensity is candle power or candela.
- Illuminance (E) of a surface is the luminous flux incident normally on unit area of the surface. Its unit is lux.
- Luminance or brightness (B) of a surface is the luminous flux reflected into our eyes from unit area of the surface. Its unit is lambert.
- According to Lambert's cosine law, $E \propto \cos\theta$, where θ is the angle which the incident light makes with normal to the surface at that point.
- A photometer is used for comparing the luminous intensities of two sources.
- Velocity of light, $c = \frac{\text{distance travelled}}{\text{time taken}}$ and the most accurate value of $c = 2.99797 \times 10^8$ m/s.

Reflection of light

- **Reflection of light** is the phenomenon of change in the path of light without change in medium.
- **Laws of reflection :**
 - (i) The incident ray, the reflected ray and the normal to the surface all lie in the same plane.
 - (ii) The angle of incidence (i) is equal to the angle of reflection (r).
- **Plane mirror :** *For image due to a plane mirror*
 - (i) Size of image = size of object
Magnification = unity
 - (ii) Distance of image (behind mirror) = distance of object
 - (iii) Image is erect and virtual.
 - (iv) There is a lateral inversion in the image.
 - (v) A plane mirror may form a virtual as well as real image.

- Size of plane mirror = half the size of a person. A man of 6' height may see his full image in a mirror of 3' height.
- **Number of images of a object**
When two plane mirrors are held at an angle θ , the number of images of an object placed between them is given as below.

(i) $n = \left(\frac{360}{\theta^\circ} - 1 \right)$ where $\frac{360}{\theta^\circ}$ is an integer.

(ii) $n =$ integral part of $\frac{360}{\theta^\circ}$ when $\frac{360}{\theta^\circ}$ is not an integer.

- A thick mirror forms a number of images, out of which second one is the brightest.
- Kaleidoscope and periscope employ the principle of image formation by plane mirrors.
- A plane mirror may form a real image, when the pencil of light incident on the mirror is convergent. Children, during their play, form an image of Sun on wall by a strip of plane mirror.
- **Convex mirror** : Image formed is always diminished, virtual, erect and behind the mirror.

- Focal length of mirror = $\frac{1}{2} \times$ radius of curvature of the mirror
 $\Rightarrow f = R/2$.

- Field of view is large as the image formed is diminished.

- $\frac{1}{v} + \frac{1}{u} = \frac{1}{f}$

Using the convention of signs of coordinate geometry, when light travels from left to right, u is -ve and v, f, R , magnification $\left(m = \frac{\text{size of image}}{\text{size of object}} = \frac{S.I.}{S.O.} \right)$, $S.I.$ and $S.O.$ are all +ve.

- When object is situated at pole of mirror, the image is also formed at the pole of the surface. The behaviour at pole is same as with a plane mirror.
- A convex mirror is used in street lights and by the side of driver of a car/scooter for seeing the back-view. The large field of view helps in movement of vehicle ahead.

- **Concave mirror** :

Formula, $\frac{1}{f} = \frac{1}{v} + \frac{1}{u}$

- $R = 2f$
- A concave mirror forms variety of real and virtual images.
- For all real images which are formed on the side of object, v, u, f , magnification, R and height of image are -ve. Height of object is +ve. Sign convention of coordinate geometry is followed. Object is situated to left of mirror. Incident rays travel from left to right.
- For virtual image $v, S.I., S.O.$ and m are +ve while u, f, R are -ve.
- Real image of same size is formed at the object itself only with a concave mirror. The object should be placed at centre of curvature. The real image is also formed at C . Magnification = -1.

- When object is placed at pole of concave (or convex) mirror, virtual image of same size is formed at the pole itself. It is, in fact, a plane mirror behaviour for this position of object.
- A concave mirror is used in search lights, head lights and torches. It is also used as mirror for shaving and make-up purposes where in a virtual image, larger than the object is formed, to display details of the object.
- For concave mirror, $f^2 = x_1 x_2$ where x_1 and x_2 denote distances of object and its image from focus of concave mirror. This is known as **Newton's formula**. The formula does not apply to convex mirror.

Refraction of light

- When a ray of light is incident on the boundary between two transparent media, a part of it passes into the second medium with a change in direction. This phenomenon is called **refraction**.
- **Laws of refraction :**
 - (i) The incident ray, the refracted ray and the normal all lie in the same plane.
 - (ii) **Snell's law** : The ratio of the sine of the angle of incidence to the sine of angle of refraction is constant for two given media. This constant is called refractive index (μ) of medium 2 with respect to medium 1. *i.e.* $\mu = \sin i / \sin r$, where i is the angle of incidence and r is the angle of refraction.
- **Refractive index (μ) - In short, R.I. (μ)** : Refractive index of a material depends upon four factors as follows:
 - (i) **Material** : Refractive index is maximum for diamond. Its value is 2.42. It is rated to be one for vacuum or almost unity for air. This value of R.I. is minimum.
 Refractive index of carbon di sulphide liquid ≈ 1.6
 Refractive index of water = $4/3 = 1.33$
 Refractive index of glass = $3/2 = 1.50$
 Refractive index of glycerine $\approx 1.47 \approx 1.50 \approx$ R.I. of glass
 - (ii) **Colour of light**
 - Refractive index of violet colour is maximum while that for red light is minimum.
 $\mu_V > \mu_R$.
 VIBGYOR denotes seven colours in descending order of R.I.
 Thus $\mu_V > \mu_I > \mu_B > \mu_G > \mu_Y > \mu_O > \mu_R$.
 - $\mu = \frac{\text{constant}}{\lambda^2}$ generally. Specifically, $\mu = A + \frac{B}{\lambda^2} + \frac{C}{\lambda^4}$. This is **Cauchy's formula**.
 - (iii) **Temperature/density**
 - $\frac{\mu - 1}{\rho} = \text{constant}$, where ρ denotes density of material. Since density decreases with rise of temperature, R.I. also decreases with rise of temperature.
 - μ is inversely proportional to temperature, $\left(\mu \propto \frac{1}{T} \right)$

(iv) *Surrounding media*

- R.I. of medium y with respect to medium x is represented as ${}^x\mu_y$ or μ_{xy} and here the ray of light travels from x to y .
- If light travels from y to x , R.I. = ${}^y\mu_x$.

$$\frac{1}{{}^y\mu_x} = {}^x\mu_y \quad \text{or} \quad {}^x\mu_y \times {}^y\mu_x = 1.$$

- If glass is surrounded by water, R.I. = ${}^w\mu_g$.

$${}^w\mu_g = \frac{{}^a\mu_g}{{}^a\mu_w} = \frac{3/2}{4/3} = \frac{9}{8}.$$

- **R.I., speed of light, wavelength of light**

${}^x\mu_y$ = R.I. of y with respect to x .

$${}^x\mu_y = \frac{\text{speed of light in medium/material } x}{\text{speed of light in medium/material } y}$$

- In a given transparent medium/material, velocity of light is not same for all colours. It is different for different colours/wavelengths λ /frequencies n . Red colour travels fastest and violet light travels slowest in a given transparent medium/material.

$$v_R > v_O > v_Y > v_G > v_B > v_I > v_V$$

- In vacuum, all colours travel with the same speed. Velocity of light in vacuum is an absolute constant. Its value is, $c = 3 \times 10^8$ m/s. It does not depend upon colour (wavelength or frequency) of light, amplitude, intensity of light, velocity of source or velocity of observer.
- Quantities which remain constant during refraction are
 - frequency of light. Frequency depends upon source of light.
 - Phase angle.
- Quantities which change during refraction are:
 - Speed of light. Denser the medium, less the velocity.
 - Wavelength of light. Denser the medium, less the wavelength.
 - Amplitude of light.
 - Intensity of light. This is due to the partial reflection and partial absorption of light.
- The cause of refraction is that light travels faster in a rarer medium than in a denser medium.

$${}^x\mu_y = \frac{\text{speed of light in } x}{\text{speed of light in } y} = \frac{n\lambda_x}{n\lambda_y} = \frac{\lambda_x}{\lambda_y}$$

Frequency n does not change during refraction.

- ${}^a\mu_m$ = R.I. of medium m with respect to a (or vacuum)

$${}^a\mu_m = \frac{\text{speed of light in vacuum } (c)}{\text{speed of light in medium } (v)} = \frac{\lambda_a}{\lambda_m}$$

Denser the medium (*i.e.* greater ${}^a\mu_m$), less the speed of light in it and less the wavelength of light in it (the medium).

$$\therefore {}^a\mu_m \propto \frac{1}{\lambda_m}.$$

- **Apparent depth** - If an object is placed below the surface of water or under a glass slab, it appears to be raised. *i.e.* the apparent depth is less than the real depth. This is due to refraction. Refractive index (μ) can also be given as

$$\mu = \text{real depth/apparent depth.}$$

- **Total internal reflection** is the phenomenon of reflection of light into the denser medium from the boundary of the denser medium and rarer medium.
- The angle of incidence (i) in denser medium for which the angle of refraction in rarer medium is 90° is called the critical angle for the pair of media under consideration.
- **Refractive index (R.I.) and critical angle**

Critical angle is the angle of incidence in denser medium for which angle of refraction in rarer medium is 90° .

$${}^m\mu_a = \frac{\sin i}{\sin r} \text{ by Snell's law.}$$

Ray travels from the denser medium to air

$${}^m\mu_a = \frac{\sin C}{\sin 90^\circ} = \sin C \quad \text{or,} \quad {}^a\mu_m = \frac{1}{\sin C} = \text{cosec } C.$$

- Critical angle increases with temperature.
- Denser the medium, less the critical angle.
- Regarding colour/wavelength or frequency of light, $\mu_V > \mu_R$. Hence $C_V < C_R$.
Critical angle for violet colour is lowest.
Critical angle for red colour is highest.
- Critical angle for diamond = 24°
Critical angle for glass = 42°
Critical angle for water = 48°
- Total internal reflection occurs if angle of incidence in denser medium exceeds critical angle.
- Mirage is an optical illusion observed in deserts and roads on a hot day when the air near the ground is hotter and hence rarer than the air above.
- Optical fibres consist of long fine quality glass or quartz fibres, coated with a thin layer of a material of lower refractive index. The device is used as a light pipe in medical diagnosis and for optical signal transmission.
- A **lens** is a piece of transparent refracting material which is bounded by two spherical surfaces or by one spherical surface and one plane surface.
- When the lens is thicker in the middle than at the edges, it is called a convex lens or converging lens. When it is thinner in the middle, it is called a concave lens or diverging lens.
- The image formed by a concave lens is always virtual, erect and diminished and lies between the lens and F for all positions of the object.
- **Lens's maker's formula** : $\frac{1}{f} = (\mu - 1) \left(\frac{1}{R_1} - \frac{1}{R_2} \right)$ where μ is the refractive index of the material of the lens with respect to the outer medium, R_1 is the radius of curvature of the surface facing the object and R_2 that of the other surface.

- **Sign convention for radii of curvature** - When the centre of curvature is on the same side as the outgoing light, R is positive, otherwise it is negative.
- The focal length of a convex lens is positive and that of a concave lens is negative.
- **The lens equation** is $\frac{1}{v} - \frac{1}{u} = \frac{1}{f}$
where u is the distance of the object from the lens, v is the distance of the image from the lens and f is the focal length.
- Linear magnification is given as $m = v/u$.
- For a convex lens m is positive, when object lies between F and optical centre of lens, and image is virtual. m is negative when object lies beyond F and image is real.
- For a concave lens, m is positive as image is always erect and virtual.
- Areal magnification, $m_A = \frac{\text{area of image}}{\text{area of object}} = \frac{v^2}{u^2} = m^2$.
- The reciprocal of focal length of a lens is called its power. Power $P = 1/f$.
- If two thin lenses, having focal lengths f_1 and f_2 are placed in contact, then the equivalent focal length F of the combination is given by
$$\frac{1}{F} = \frac{1}{f_1} + \frac{1}{f_2} \text{ and power } P = P_1 + P_2.$$
- When two thin lenses are separated along an axis by a distance x , $\frac{1}{F} = \frac{1}{f_1} + \frac{1}{f_2} - \frac{x}{f_1 f_2}$
$$P = P_1 + P_2 - x \cdot P_1 P_2.$$
- As the refractive index is different for different colours, the image of an object illuminated by white light gets spread out. The violet colour is focussed nearest to the lens and the red farthest. This defect is known as **chromatic aberration**.
- In astigmatism, horizontal and vertical lines may be focussed in different planes.
- If an object not on the principal axis may not come to a sharp focus but converge in a comet shaped figure, the defect is called coma.
- Distortion happens due to non-uniform magnification of images at different points.
- A ray of light suffers two refractions at two surfaces on passing through a prism.
- **Prism formula** is given as $\mu = \frac{\sin[(A + \delta_m)/2]}{\sin(A/2)}$
where δ_m is the minimum deviation and A is the angle of the prism.
- **Dispersion of light** is the phenomenon of splitting of white light into its constituent colours on passing through a prism. This is because different colours have different wavelengths.
- Angular dispersion $= \delta_v - \delta_r = (\mu_v - \mu_r)A$, where μ_v and μ_r represents refractive index for violet and red lights.
- Dispersive power, $\omega = \frac{\mu_v - \mu_r}{\mu - 1}$, where $\mu = \frac{\mu_v + \mu_r}{2}$ is the mean refractive index.
- **Spectra** obtained from luminous bodies are called emission spectra. These are of three types.

- (i) *Line spectrum* : It consists of narrow bright lines separated by dark intervals.
- (ii) *Band spectrum* : It consists of a number of bright bands separated by dark intervals and contains a large number of close lines.
- (iii) *Continuous spectrum* : A continuous spectrum consists of an unbroken sequence of wavelength over a wide range.
- **Absorption spectra** - When white light passes through a semi-transparent solid, liquid or gas its spectrum contains certain dark lines or bands, showing that certain wavelengths have been absorbed. Such a spectra is called the absorption spectrum.
- The solar spectrum shows several dark lines crossing the otherwise continuous spectrum. These are called **Fraunhofer lines**.
- The amount of scattering by molecules (Rayleigh scattering) is inversely proportional to the fourth power of the wavelength.

The eye

- In **myopia or short sightedness**, only nearby objects can be seen distinctly. Far point of eye shifts from infinity to a distance d . To remove this defect, a concave lens of focal length (d) has to be used.
- In **hypermetropia or long-sightedness**, only far off objects can be seen distinctly. Near point of eye shifts away from the eye. To remove this, a convex lens of focal length (f) has to be used.
- **Astigmatism** - An astigmatic eye cannot focus on horizontal and vertical lines at the same distance at the same time. This can be corrected by using suitable cylindrical lenses.

Camera

- **f -numbers**
 - (i) The f -numbers represent the size of the aperture.
 - (ii) Usually, f -numbers are 2, 2.8, 4, 5.6, 8, 11, 22, 32.
 - (iii) The diameter of aperture = d
- The amount of light (L) entering the camera is directly proportional to the area A of the aperture. A depends on diameter of aperture d .

$$d = \frac{\text{focal length of the lens}}{f\text{-number}}$$

$$L \propto A \propto d^2$$

- Brightness of image B is proportional to d^2/f^2 .

$$\text{or } B \propto \frac{1}{(f\text{-number})^2}$$

- Exposure number E determines time of exposure T .

$$T \propto \frac{1}{E\text{-number}}$$

- Time of exposure T

$$T \propto \left(\frac{1}{f\text{-number}} \right)^2 \times \left(\frac{1}{E\text{-number}} \right)$$

- **Depth of focus**

It refers to the range of distance over which the object may lie so as to form a good quality image. Larger the f -numbers, greater will be the depth of focus.

Simple microscope

- A simple microscope consists of a convex lens of small focal length *i.e.* large power.
- Magnifying power = M

(i) For distinct vision, $M = 1 + \frac{D}{f}$.

The final image is formed at the least distance of distinct vision from eye.
This distance D is about 25 cm.

(ii) For normal vision, $M = \frac{D}{f}$.

The final image is formed at infinity for normal vision setting.

Compound microscope

- A compound microscope consists of an objective and an eyepiece.
The objective is a convex lens of small focal length f_o .
The eye-piece is a convex lens of small focal length f_e but $f_o < f_e$.
- **Magnifying power for distinct vision**

$$M = \frac{v_o}{u_o} \left(1 + \frac{D}{f_e} \right)$$

- **Magnifying power for normal vision**

$$M = \frac{v_o}{u_o} \cdot \frac{D}{f_e}$$

- Crosswires may be used for measurement purposes.
- The object is placed very near the objective but beyond the focus of objective.
- The objective forms a real, enlarged and inverted image of the object.
- This image serves as the virtual object for eyepiece of microscope.
- Final image is enlarged and inverted with respect to the object viewed by microscope.
- Resolving power of a microscope is given by

R.P. = $\frac{1}{d} = \frac{2\mu \sin \theta}{\lambda}$, where d is the minimum distance between two point objects which can just be resolved, λ is the wavelength of light used, μ is the refractive index of the medium between the object and lens and θ is the half angle of the cone of light from the point object on the objective lens.

Telescope

- A telescope consists of an objective and an eyepiece.
The objective is a convex lens of large focal length and large aperture. The eyepiece is a convex lens of small focal length.
 $f_o > f_e$.

- **Magnifying power for distinct vision**

$$M = \frac{f_o}{f_e} \left(1 + \frac{f_e}{D} \right)$$

The object lies at infinity.

The focal image is formed at least distance of distinct vision (D).

- **Magnifying power for normal vision**

$$M = \frac{f_o}{f_e}$$

The object lies at infinity.

The final image is also formed at infinity.

Tube length = $f_o + f_e$.

- **Resolving power of telescope**

(i) The ability of an optical instrument to produce separate diffraction patterns of two nearby objects is known as resolving power.

(ii) The reciprocal of resolving power is defined as the **limit of resolution**.

(iii) For telescope,

$$\text{the limit of resolution } (d\theta) = \frac{1.22\lambda}{a}$$

$$\text{Resolving power} = \frac{1}{d\theta}$$

$$\text{or Resolving power} = \frac{a}{1.22\lambda}$$

(iv) $d\theta \propto \lambda$ (wavelength of light used)

$$d\theta \propto \frac{1}{a} \quad (a = \text{diameter of aperture of objective}).$$

Salient points about ray optics

- Continuous spectrum is produced by red hot bodies, electric bulbs, electric arc, sun, red hot gases etc.
- Band/molecular spectrum is produced by gases excited in molecular form. Discharge tubes containing gases at low pressure produce band spectra.
- Line spectrum is produced by substances excited in atomic form. Lamps of sodium and mercury give line spectra.
- When light is reflected by a denser medium, phase difference of π radian or path difference of $\lambda/2$ or time difference $T/2$ is produced. This is known as **Stoke's law**.
- Path of light is reversible.
- Distance x travelled by light in a medium of refractive index μ is equal to distance (μx) travelled in vacuum.
- Time taken by light to traverse a thickness x of medium of refractive index μ ,

$$\text{time} = \frac{\mu x}{c} \quad \text{where } c = \text{velocity of light in vacuum.}$$

- **Cauchy's formula:** $\mu = A + \frac{B}{\lambda^2} + \frac{C}{\lambda^4}$

μ denotes refractive index and λ denotes wavelength of light.

Generally speaking, $\mu \propto \frac{1}{\lambda^2}$.

- **Illustration of scattering of light**

- (i) Blue colour of sky
 - (ii) Red colour of signals of danger
 - (iii) Red colour at the time of sun-rise and sun-set
 - (iv) Black colour of sky in the absence of atmosphere
- The human eye is most sensitive to yellow colour.
 - For large magnifying power of a telescope, f_o should be large and f_e should be small.
 - For large magnifying power of a microscope, $f_o < f_e$ but f_e should be small.
 - **Eye-pieces**
 - (i) Huygen's eye piece is free from chromatic and spherical aberrations but it cannot be used for measurement purposes.
 - (ii) Ramsden's eye piece can be used for precise measurement as cross wires can be fixed in this eye-piece. It slightly suffers from spherical and chromatic aberrations.

End

wave optics

- **Wave optics** is based on wave theory of light put forward by Huygen. According to wave theory, light is a form of energy which travels through a medium in the form of transverse waves.

Light

- Light is a form of energy.
- Light travels even in vacuum. It does not require a material medium for its propagation.
- Light travels fastest in vacuum, its velocity being 3×10^8 m/s.
- Light belongs to visible part of electromagnetic spectrum. The wavelength of light ranges from 4000 Å (violet colour) to 8000 Å (red colour).
- Frequency of light is of the order of 10^{15} hertz.
- Energy contained in mean colour (yellow = 6000 Å) is of the order of 2 eV.
- Velocity of light remains constant in all inertial frames *i.e.* it is an absolute constant.
- Light travels with different speeds in different media. It travels faster in rarer medium than in denser medium. Denser the medium, less the velocity.
- Properties of medium through which light traverse remain unaffected due to light transmission.
- Light exhibits character of a transverse wave.
- It undergoes reflection, refraction, interference, diffraction, polarisation, double refraction, total internal reflection and rectilinear propagation.
- Light produces thermal effect, photoelectric effect, Compton effect and Raman effect.
- Light exhibits dual nature. In some phenomenon it behaves like waves and in some other phenomenon it behaves like particles. It does not have both the natures simultaneously.
- Energy = $h\nu = hc/\lambda$ and momentum = h/λ (h = Planck's constant).

Theories of light

- **Newton's corpuscular theory**
 - (i) Light consists of extremely small, invisible elastic particles travelling in vacuum with a speed of 3×10^8 m/s.
 - (ii) The theory could explain reflection and refraction.
 - (iii) It could not explain interference, diffraction, polarisation, photoelectric effect and Compton effect. The theory failed as it could not explain why light travels faster in a rarer medium than in a denser medium.

• **Huygen's wave theory**

- (i) Light travels in a medium in the form of wavefront where a wavefront is the locus of all the particles vibrating in same phase.
 (ii) When source of light is a point source, the wavefront is spherical. Amplitude (A) is inversely proportional to distance (x) i.e. $A \propto 1/x$.

$$\text{Intensity } (I) \propto \frac{1}{x^2} \propto (\text{amplitude})^2.$$

- (iii) When source of light is linear, the wavefront is cylindrical. Amplitude (A) $\propto \frac{1}{\sqrt{x}}$ and intensity $\propto (\text{amplitude})^2 \propto \frac{1}{x}$.

- (iv) At very large distance from the source (or an extended large source), a portion of spherical or cylindrical wavefront appears to the plane. In this case amplitude and intensity remain constant.
 (v) A wavefront travels parallel to itself and perpendicular to the rays.
 (vi) Wavefront always travels in the forward direction of the medium.
 (vii) In an anisotropic medium, a point source gives rise to an elliptic wavefront.
 (viii) Hygen's/Huygen's wave theory could explain reflection, refraction, interference and diffraction of light.
 (ix) It failed to explain polarisation of light. It assumed the light waves to be longitudinal and hence failed to explain polarisation. It also could not explain backward propagation of light, photoelectric effect, Compton effect and Raman effect.

• **Maxwell's electromagnetic theory**

- (i) The electromagnetic waves are transverse waves which require no material medium for propagation. They can travel through vacuum.
 (ii) Due to transverse nature, light waves undergo polarization.
 (iii) In these waves, the electric field vector (\vec{E}) and magnetic field vector (\vec{B}) vibrate in same phase along mutually perpendicular directions.

- (iv) \vec{E} and \vec{B} are perpendicular to the direction of velocity of light \vec{c} . Thus

$$\vec{E} \perp \vec{B} \perp \vec{c}$$

Their instant magnitudes are related as

$$\frac{E}{B} = c = 3 \times 10^8 \text{ m/s.}$$

- (v) The velocity of electromagnetic waves in vacuum is

$$c = \frac{1}{\sqrt{\mu_0 \epsilon_0}} \text{ where}$$

μ_0 = absolute magnetic permeability

ϵ_0 = absolute electrical permittivity of free space

- (vi) The velocity of electromagnetic waves in medium is less than that of light.

$$v < c.$$

$$v = \frac{1}{\sqrt{\mu_0 \epsilon_0 \epsilon_r \mu_r}} = \frac{c}{\sqrt{\mu_r \epsilon_r}}$$

The velocity of electromagnetic waves in a medium depend upon the electric and magnetic properties of the medium.

- (vii) It explained the phenomenon of reflection, refraction, interference, diffraction and polarisation.
- (viii) It failed to explain the phenomenon of photoelectric effect, Compton effect and Raman effect.
- **Max Planck's quantum theory**
 - (i) Light consists of packets of energy which are known as quanta or photons.
 - (ii) The photons are emitted discretely and not continuously.
 - (iii) The energy of photons is given by $E_n = nh\nu$ where n is an integer and represents the number of photons.
Energy of a single photon = $h\nu = hc/\lambda$.
 - (iv) The velocity of photon is equal to that of light.
 - (v) The rest mass of photon = zero.
 - (vi) The effective mass of photon $m = \frac{h\nu}{c^2} = \frac{h}{c\lambda} = \frac{\text{energy } E}{c^2}$.
 - (vii) Their spin is $\hbar = \frac{h}{2\pi}$, $h = \text{Planck's constant}$.
 - (viii) Momentum of photon = $p = mc = \frac{h}{\lambda} = \frac{h\nu}{c} = \frac{\text{Energy } E}{c}$
 - (ix) Photons are electrically neutral.
 - (x) Quantum theory could explain photoelectric effect, Compton effect and Raman effect.
 - (xi) Quantum theory failed to explain interference, diffraction and polarisation of light.
 - **de Broglie's dual theory**
 - (i) Light behaves both as corpuscle and also as wave.
 - (ii) The corpuscular and wave aspects are like the two faces of a coin which can never be separated. Light does not exhibit both the aspects simultaneously. In some phenomenon it behaves like transverse waves (as in interference, diffraction and polarisation) and in other phenomenon it behaves like particles (as in photoelectric effect, Compton effect and Raman effect). This dual theory explains all the phenomenon and effects of light.
 - (iii) As wave, its energy = $h\nu = \frac{hc}{\lambda}$.
As particle, its momentum = h/λ .
where $h = \text{Planck's constant} = 6.6 \times 10^{-34} \text{ joule} \times \text{sec}$.
 - (iv) G.P. Thomson and Davisson and Germer experimentally verified this theory.
 - (v) de-Broglie wave equation is $\lambda = \frac{h}{p} = \frac{h}{mv}$ where h denotes Planck's constant.

Huygen's principle

- **Huygen's principle** states that :
 - (i) Every point on given wavefront (called primary wave front) acts as a fresh source of new disturbance, called secondary wavelets.
 - (ii) The secondary wavelets travel in all the directions with the speed of light in the medium.
 - (iii) A surface touching these secondary wavelets tangentially in the forward direction at any instant gives the new (secondary) wavefront at that instant.

Interference of light

- When two light waves of exactly equal frequency having a phase difference which is constant with respect to time travel in same direction and overlap each other then the intensity is not uniform in space. The phenomenon of non-uniform distribution of energy in the medium due to superposition of two such light waves is called interference of light.
- The interference pattern in which the position of maxima and minima of intensity of light remain fixed all along on the screen is called **sustained** or **permanent interference** pattern.
- At the points where resultant intensity is maximum, interference is said to be constructive.
- At the points where the resultant intensity is minimum, interference is said to be destructive.
- The condition for constructive interference is that path difference between two waves should be zero or an integral multiple of full wavelength.
- The condition for destructive interference is that path difference between two waves should be an odd integral multiple of half the wavelength.
- A soap film or a thin film of oil spread over water surface, when seen in white light, appears coloured due to interference of light waves/rays reflected by them.
- Newton's rings are formed as a result of interference between the light waves reflected from the upper and a lower surface of the air film.
- In the interference of the light waves, we obtain alternate bright and dark bands of light, called interference fringes.
- **Fringe width**: The distance between the centres of two consecutive bright or dark fringes is called the fringe width.
- The angular fringe width is given by $\theta = \lambda/d$, where λ is the wavelength of light, d is the distance between two coherent sources.

Coherent source

- **Coherent sources** are those which emit continuous light waves of same amplitude, same wavelength/frequency in same phase or having a constant phase difference. Two independent sources can never be coherent. They are produced from a single source of light.
- **Division of wavefront**
 - (i) When light source is narrow, the wavefront is divided in two parts by reflection or refraction.
 - (ii) The coherent sources obtained are imaginary.
 - (iii) Young's double slit experiment, Fresnel's biprism and Lloyd's mirror use this technique for coherent sources.
- **Division of amplitude**
 - (i) When light source is extended, the amplitude of wave is divided in two parts by partial reflection and partial refraction.
 - (ii) The coherent sources obtained are real.
 - (iii) Newton's rings, Michelson's interferometer and colour of thin films use this technique for obtaining two coherent sources.

- **Fresnel's biprism** : The biprism is a device to obtain two coherent sources to obtain sustained interference. It is a combination of two prisms of very small refracting angles placed base to base.
- **Lloyd's mirror** : It is an equipment which is used for obtaining coherent sources of light by reflection from a plane mirror. Only half of the interference pattern is available. The central fringe is dark.

Shapes of fringes

- The interference fringes are usually hyperbolic in shape. Locus of path difference between light waves from two slits is a hyperbola. The alternate bright and dark strips comprise these fringes.
- When the screen is held at 90° to the line joining foci of the hyperbola, the fringes are circular.
- When distance of screen (D) is very large compared to the distance between the slits (d), the fringes are straight.

$$D \gg d.$$

Thomas Young's double slit experiment

- In this experiment, two points of the same wavefront are used as two coherent sources.
- Interference fringes obtained in Young's experiment consist of alternate bright and dark bands.
- All bright fringes have same intensity and all dark fringes are perfectly dark.
- Bright fringes are due to constructive interference. Dark fringes are due to destructive interference.
- The central fringe is bright with monochromatic light. It is achromatic/white with white light.
- If W_1 and W_2 represents width of two slits, I_1 and I_2 represents intensities of light from two slits, a and b represent amplitudes of waves from two slits, then

$$\frac{W_1}{W_2} = \frac{I_1}{I_2} = \frac{a^2}{b^2}.$$

- **Bright fringe**

- Let n = order of fringe
 x = distance of n^{th} bright fringe from centre
 d = distance between two coherent sources
 D = distance between screen and slit/source
 λ = wavelength of light

For n^{th} bright fringe, path difference = $\frac{xd}{D} = n\lambda$.

- $n = 0$. For central bright fringe, $x = 0$.

- $n = 1$ for first bright fringe. $\therefore x_1 = \frac{Dn\lambda}{d} = \frac{D\lambda}{d}$.

- $n = 2$ for second bright fringe. $\therefore x_2 = \frac{2D\lambda}{d}$.

$$(v) \text{ Width of bright fringe} = \beta = (x_2 - x_1) = \frac{\lambda \cdot D}{d}$$

- **Dark fringe**

$$(i) \text{ For } n^{\text{th}} \text{ dark fringe, path difference} = \frac{xd}{D} = \frac{(2n-1)\lambda}{2}$$

$$(ii) \ n = 1 \text{ for 1st dark fringe, } x_1' = \frac{D\lambda}{2d}$$

$$(iii) \ n = 2 \text{ for 2nd dark fringe, } x_2' = \frac{3D\lambda}{2d}$$

$$(iv) \text{ Width of dark fringe} = (x_2' - x_1') = \frac{\lambda D}{d}$$

- Width of bright fringe = width of dark fringe = $\beta = \frac{\lambda D}{d}$.
- When source gives white light, interference fringes are coloured. Red fringes are wider as λ_R is large ($\lambda_R = 8000 \text{ \AA}$). Although the fringes are coloured, the centre of interference pattern is white. All the colours meet in the same phase, with zero path difference, at the centre.
- If an additional phase difference of π radian is introduced in one of the waves, then the central fringe becomes dark.
- Fringe width $\beta = \frac{\lambda D}{d}$.
 - (i) If D increases, β increases and vice-versa.
 - (ii) If d increases, β decreases and vice-versa.
 - (iii) If λ decreases, β decreases. If the experiment is performed in water, instead of air, then λ decreases and consequently β decreases.
- With white light if $D \gg d$, the missing wavelengths in interference pattern are given by $\lambda = \frac{d^2}{D}, \frac{d^2}{3D}, \frac{d^2}{5D}$ and so on.
- When $d < \lambda$, $\frac{d}{\lambda} = \frac{D}{\beta}$ or $\frac{D}{\beta} < 1$ or $\beta > D$.
 $\beta > D$ means fringe pattern will not be visible.
- When both the slits are open, $I = (a + a)^2 = 4a^2$.
- When one of the slits/sources is closed, interference does not occur. A uniform illumination is obtained on screen.
- When a transparent thin film of mica or glass is inserted in the path of one of the beams, the whole of interference pattern gets shifted towards the side where the film is inserted.
- The angular half width of central maxima = $\sin \theta = \frac{\lambda}{a}$
 where a denotes width of slit.

Polarisation

- **Polarisation** of light is the phenomenon of restricting the vibrations of light (electric vector) in a particular direction; on passing ordinary light (unpolarised) through certain crystals like tourmaline crystal. The crystal acts as a polariser.

- The plane in which vibrations of polarised light are confined is called plane of vibration.
- A plane perpendicular to the plane of vibration is called plane of polarisation.
- The angle between plane of vibration and direction of propagation of wave is 0° .
- The angle between plane of polarisation and direction of propagation of wave is 0° .
- According to **Law of Malus**, when a beam of completely plane polarised light is incident on an analyser, the resultant intensity of light (I) transmitted from the analyser varies directly as the square of the cosine of the angle (θ) between plane of transmission of analyser and polariser.
i.e. $I \propto \cos^2\theta$.
- According to **Brewster's law**, when unpolarised light is incident at polarising angle (i_p) on an interface separating a rarer medium from a denser medium of refractive index μ , such that $\mu = \tan i_p$, then light reflected in the rarer medium is completely polarised.
- Optical rotation is the phenomenon of rotating the plane of polarisation of light about the direction of propagation of light, when passed through certain crystals or solutions.
- The substances which rotate the plane of polarisation are called optically active substances. They are of two types: **dextro rotatory** (clockwise direction) and **laevo rotatory** (anti-clockwise direction).
- *Quartz* is dextro-rotatory as well as laevo rotatory.
- **Double refraction** : When a ray of unpolarised light incident on a calcite (or quartz) crystals, splits up into two refracted rays, the phenomenon is called double refraction.
- **Dichroism** : Some doubly-refracting crystals have the property of absorbing strongly one of the two refracted rays and allowing the other to emerge with little loss. This selective absorption by the crystal is known as dichroism. e.g. tourmaline crystal.
- **Polaroid** : It is a very big polarising film mounted between two glass plates and is used to obtain plane-polarised light for commercial purposes.

Diffraction

- **Diffraction** of light is the phenomenon of bending of light around corners of an obstacle or aperture in the path of light.
- **Fraunhofer diffraction due to a single slit**
 - (i) *Width of central maximum*
 - (a) Half linear width x is given by $\theta = \frac{\lambda}{a} = \frac{x}{f}$ or $x = \frac{f\lambda}{a} = f\theta$
 - (b) Linear width W or $2x$ is given by $W = 2x = \frac{2f\lambda}{a}$
where a = slit width, f = focal length of convex lens,
 λ = wavelength of monochromatic light.
 - (ii) *Angular width W*
$$W_\theta = \frac{W}{f} = \frac{2\lambda}{a}$$
 - (iii) *For secondary minima*
 - (a) Linear distance, $L = \frac{n\lambda D}{a} = \frac{n\lambda f}{a}$

- (b) Angular spread, $L_0 = \frac{L}{f} = \frac{n\lambda}{a}$
- (iv) For secondary maxima
- (i) Linear distance, $L = \frac{(2n-1)\lambda D}{2a} = \frac{(2n-1)\lambda f}{2a}$
- (ii) Angular spread, $L_0 = \frac{L}{f} = \frac{(2n-1)\lambda}{2a}$
- Secondary maxima of decreasing intensities and minima are obtained on both sides of the central maximum.
 - **Diffraction grating** is an optical device, which is used for studying the spectra of sources of light and the determination of wavelength of light.
 - Dispersive power of a grating is defined as the rate of change of angle of diffraction with wavelength of light.
 - The dispersive power, $\frac{d\theta}{d\lambda} = \frac{n}{(e+d)\cos\theta}$, where $(e+d)$ is the grating element.
 - Difference between interference and diffraction is that interference is the superposition effect between the wavelets starting from two coherent sources while the diffraction is the superposition effect between the wavelets starting from the single wave front.

Some salient features about wave optics

- Light waves are transverse waves.
- They are electromagnetic in character. The wavelength ranges from 4000 Å (violet) to 8000 Å (red).
- Light exhibits polarization. This property establishes its transverse nature.
- Light exhibits dual nature. It behaves as particle having momentum $p = \frac{h}{\lambda} = \frac{h\nu}{c}$ and as transverse wave having energy $E = h\nu = \frac{hc}{\lambda}$.
- In any medium of refractive index μ , velocity of light is given by $v = c/\mu$ where c denotes velocity of light in vacuum.
- The maximum possible velocity is the velocity of light in vacuum. $c = 10^8$ m/s.
- When two waves of intensities I_1 and I_2 and phase difference ϕ superimpose, the resultant intensity is given by

$$I = I_1 + I_2 + 2\sqrt{I_1 I_2} \cos \phi.$$
- In the interference pattern, $\frac{I_{\max}}{I_{\min}} = \frac{(a+b)^2}{(a-b)^2}$ where a and b represent amplitudes of individual waves.
- Fringe visibility = $V = \frac{I_{\max} - I_{\min}}{I_{\max} + I_{\min}} = \frac{2\sqrt{I_1 I_2}}{I_1 + I_2}$.
 If $I_{\min} =$ zero, then $V = 1$. The visibility is best.
 $I_{\min} = (a-b)^2 = 0$ or $a = b$, i.e. the two individual waves should have equal amplitudes for best visibility.

- When Young's experiment is performed under water, the λ decreases. $\beta = \frac{\lambda D}{d}$ hence β decreases.
- When a thin transparent plate of thickness t and refractive index μ is introduced in the path of one of the interfering waves, fringe width $\beta = \frac{\lambda D}{d}$ remains as such but n^{th} bright fringe shifts by a distance x where $x = \frac{D}{d}(\mu - 1)t$.

$$\Rightarrow (\mu - 1)t = \frac{xd}{D} = n\lambda.$$
- According to Hygen's/Huygen's principle,
 - (i) Every point on a given wavefront, known as primary wavefront, acts as a fresh source of new disturbance, known as secondary wavelets.
 - (ii) The secondary wavelets propagate in all directions with the speed of light in the medium.
 - (iii) A new (secondary) wavefront at an instant starts from a surface, touching these secondary wavelets tangentially in the forward direction, at that instant.
- When one of the slits/coherent sources is closed no interference occurs. Uniform illumination results.
- When one of the slits is partially closed, the contrast between the fringes decreases.
- When one of the slits is covered with red and the other with blue transparent sheet, no interference pattern is formed.
- When a light wave is reflected from the surface of an optically denser medium, it suffers a phase change of π , but it suffers no change in phase when reflected at the surface of optically rarer medium.
- Diffraction fringes are obtained instead of interference fringes where one of the slits is closed and width of the other is of the order of λ , the wavelength of light.
- When $D \gg d$, then in front of one of the slits, the wavelengths missing will be given by

$$\lambda = \frac{d^2}{D}, \frac{d^2}{3D}, \frac{d^2}{5D} \text{ and so on.}$$

- **Time of coherence (t)**

The average time interval in which a photon is emitted from an atom is called time of coherence. It is of the order of 10^{-10} sec.

- The ratio of slit widths W_1/W_2 is $\frac{W_1}{W_2} = \frac{I_1}{I_2} = \frac{a^2}{b^2}$.
- **Radiation pressure** : The momentum imparted by the light waves to the surface of incidence per second per unit area is called radiation pressure.
- The energy of yellow light ≈ 2 eV ($\lambda = 6000 \text{ \AA}$).
- The frequency of yellow light = 0.5×10^{15} hertz.

- Yellow represents mean wavelength of light ranging from violet ($6000 \text{ \AA} = \lambda_v$) to red ($\lambda_r = 8000 \text{ \AA}$).
- Velocity of all colours/wavelengths of light is same in vacuum. $c = 3 \times 10^8 \text{ m/s}$.
- In any other transparent medium, different colours having different λ and different μ , travel with different velocities. $v = c/\mu$.
- As $\mu_v > \mu_r$, red colour travels faster than violet colour in a medium.
- During refraction, frequency of light remains constant while wavelength and velocity both change to $1/\mu$ times.

A stylized, cursive logo for the word "End". The letters are elegant and flowing, with a decorative flourish above the 'E'.

modern physics

- The passage of electric current through air is called **electric discharge** through the air.
- The voltage required for the discharge through air or gas depends upon (i) the nature of the gas, (ii) the pressure of the gas, (iii) the nature of electrodes and (iv) distance between the electrodes.
- **Cathode rays** are the stream of high speed electrons moving from cathode to anode in discharge tube at a pressure of 0.01 mm mercury.
- Properties of cathode rays:
 - Cathode rays travel in straight lines.
 - Cathode rays produce heat in metals when they fall on them.
 - Cathode rays are deflected by electric field and magnetic field.
 - When fast moving cathode rays are stopped by a metal of high atomic number, X-rays are produced.
 - Cathode rays can pass through thin aluminium or gold foils without puncturing them.
- **Specific charge** of cathode rays means charge/mass.
- Specific charge was determined by J.J. Thomson, using electric and magnetic fields applied on a fine beam of electrons, at same place but perpendicular to each other.

$$\bullet \quad \frac{e}{m} = \frac{E^2}{2VB^2}$$

- where E is the electric field applied, B is the magnetic field applied and V is the potential difference between anode and cathode, under which the electron is accelerated before entering the electric and magnetic fields.
- The value of specific charge of cathode ray (or electron) is $1.7589 \times 10^{11} \text{ C kg}^{-1}$.
- The charge of the electron as determined by Millikan, was found to be $1.602 \times 10^{-19} \text{ C}$.
- Millikan's experiment proved that the minimum charge carried by all positive and negative ions is the same as the charge on the electron.
- The phenomenon of emission of electrons from metal surface by the action of light is called **photoelectric effect** and the electrons so emitted are called **photoelectrons**.
- According to quantum theory of radiation, radiation consists of tiny packets of energy called **photons** or light quanta.
- Each photon has a definite amount of energy given by $h\nu$, $2h\nu$, $3h\nu$, ... where h is Planck's constant and ν is the frequency of the radiation.
- The rest mass of the photon is zero while the mass equivalent of moving photon is $h\nu/c^2$.

- The minimum quantity of energy needed to remove an electron from metal surface is called work function.

- Laws of photoelectric effect**

- (i) For a given photosensitive material and frequency of incident radiation (above the threshold frequency), the photoelectric current is directly proportional to the intensity of light.

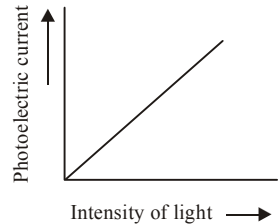

- (ii) For a given photosensitive material and frequency of incident radiation, saturation current is found to be proportional to the intensity of radiation whereas the stopping potential is independent of intensity.

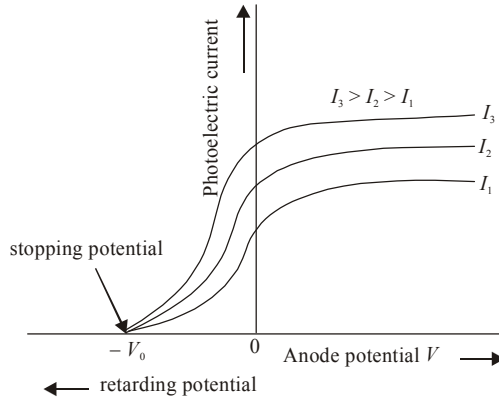

- (iii) For a given photosensitive material, there exists a certain minimum cut-off frequency, called the threshold frequency, below which no emission of photoelectrons takes place, no matter how intense the light is. Threshold frequency is different for different metals. Above the threshold frequency, the stopping potential or equivalently the maximum kinetic energy of the emitted photoelectrons increases linearly with the frequency of the incident radiation, but is independent of its intensity.

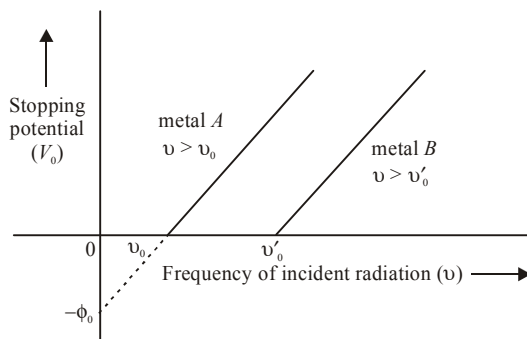

- (iv) The maximum kinetic energy of the photoelectrons or stopping potential varies linearly with the frequency of incident radiation, but is independent of its intensity.

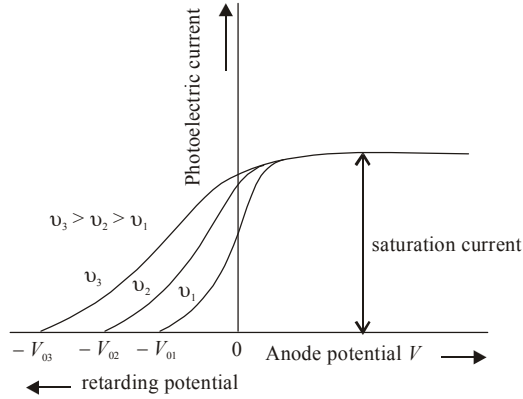

(v) The photoelectric emission is an instantaneous process.

- **Einstein's photoelectric equation**

The maximum kinetic energy of photoelectron is given by

$$K_{\max} = h\nu - \phi_0$$

where $h\nu$ is the energy of the incident photon, ϕ_0 is the work function.

- The stopping potential is directly related to the maximum kinetic energy of the electrons emitted.

$$eV_0 = \frac{1}{2}mv_{\max}^2 = K_{\max}$$

where V_0 is the stopping potential.

- When X-rays collided with a carbon plate, by collision with electrons, the scattered X-rays lost some energy. This is known as Compton effect. This is similar to the collision of particles.
- Compton gave a satisfactory explanation for the modified radiation on the basis of quantum theory.
- According to Compton effect, the change in wavelength is given by

$$\Delta\lambda = \frac{h}{m_0c} (1 - \cos\theta)$$

where h is Planck's constant, m_0 is rest mass of electron, θ is angle of scattering, c is speed of light. The shift in wavelength is called **Compton shift**.

- de Broglie introduced the idea that all moving material particles possess a wave character also.
- The waves associated with moving material particles are called **matter waves** or **de Broglie waves**.

- de Broglie wavelength (λ) = $\frac{h}{p} = \frac{h}{\sqrt{2Km}}$

where p is the momentum of the particle and K is the kinetic energy of the particle.

Dalton's atomic theory

- Postulated in 1803 by **John Dalton**.
- All elements are composed of invisible particles, called atoms.

- Atoms of same element are exactly alike.
- Atoms of different elements are not alike.
- Compounds are formed by joining atoms of two or more elements.

Thomson's atomic model

- Postulated in 1897 by **J.J. Thomson**.
- Atoms consists of positively charged protons and negatively charged electrons.
- An atom could be divided into its constituent elementary particles.
- Atom is neutral.

Rutherford's atomic model

- Postulated in 1909.
- Showed that the atom has a nucleus.
- Inside the nucleus are protons and neutrons.
- Outside the nucleus are the electrons.
- Discovered that all the positive charges are concentrated at the centre of the atoms called molecules, by shooting α -particles through a gold sheet and counting the number of particles that went through.
- Said the electrons orbit around the nucleus like the planets orbit around the sun. But could not explain why the electrons were not falling into the nucleus.
- Distance of closest approach (r_0) = $\frac{1}{4\pi\epsilon_0} \frac{2Ze^2}{E_K}$.
- r_0 depends upon the initial kinetic energy E_K of the α -particle.
- **Impact parameter** : The scattering angle θ of the α -particle and impact parameter b are related as

$$b = \frac{Ze^2 \cot(\theta/2)}{4\pi\epsilon_0 E_K}$$

where E_K is the kinetic energy of the α -particle and Z is the atomic number of the nucleus.

- Smaller the impact parameter, larger the angle of scattering θ .
- **Rutherford's scattering formula** : The formula that Rutherford obtained for alpha particle scattering by a thin foil on the basis of the Rutherford model of the atom is given by

$$N(\theta) = \frac{N_i n t Z^2 e^4}{(8\pi\epsilon_0)^2 r^2 E_K^2 \sin^4(\theta/2)}$$

where $N(\theta)$ = number of alpha particles per unit area that reach the screen at a scattering angle of θ ,

N_i = total number of alpha particles that reach the screen, n = number of atoms per unit volume in the foil, Z = atomic number of the foil atoms, r = distance of the screen from the foil, E_K = kinetic energy of the alpha particles and t = foil thickness.

Bohr's atomic model

- Postulated in 1913 by **Niels Bohr**.
- The electrons in an atom are revolving in certain fixed orbits (stationary orbits) for which the angular momentum of the electrons is an integral multiple of $h/2\pi$, where h is Planck's constant.
- The electrons in the stationary orbits do not radiate energy.
- An atom may absorb or emit discrete energy photons only when one of the electrons of an atom jumps from the lower to higher or from higher to lower orbits respectively. Thus if an electron jumps from initial state of energy E_n to a final state of (lower) energy E_m , the energy of emitted photon is given by

$$h\nu_{n,m} = E_n - E_m.$$

Stable orbits do not emit radiation by acceleration.

- Electrons revolve around the nucleus in definite orbits.
Radius of n^{th} Bohr's orbit, $r_n \propto n^2/Z$.

Wave model

- Based on wave mechanics.
- Proposed that electrons do not move in a definite orbit and that the location of the electrons is based on how much energy each electron contains.
- Quantum numbers are the numbers required to completely specify the state of the electrons.
- In the presence of strong magnetic field, the four quantum numbers are
 - (i) Principal quantum number (n), can have value 1, 2, ... ∞ .
 - (ii) Orbital angular momentum quantum number (l), can have values 0, 1, 2, ... ($n - 1$).
 - (iii) Magnetic quantum number (m_l) which can have values $-l$ to $+l$.
 - (iv) Magnetic spin angular momentum quantum number (m_s) which can have only two values $\pm 1/2$.
- The minimum accelerating potential which provides the sufficient energy for an electron to make a transition from the innermost orbit (ground state) to anyone of the outer orbit is called **excitation potential**.
- The minimum accelerating potential which provides the sufficient energy for an electron just to remove it from the atom is called **ionization potential**.
- When an electron makes a transition from n_2^{th} orbit to n_1^{th} orbit ($n_2 > n_1$), if E_2 and E_1 are the energies in n_2 and n_1 respectively,

$$\Rightarrow E_2 - E_1 = h\nu = \frac{1}{2} \frac{Z^2 e^4 m}{(4\pi\epsilon_0)^2 \hbar^2} \left[\frac{1}{n_1^2} - \frac{1}{n_2^2} \right] = \frac{1}{8} \frac{Z^2 m e^4}{\epsilon_0^2 \hbar^2} \left[\frac{1}{n_1^2} - \frac{1}{n_2^2} \right] \quad \left(\text{since } \hbar = \frac{h}{2\pi} \right)$$

$$\Rightarrow \nu = \frac{Z^2 e^4 m}{8\epsilon_0^2 \hbar^3} \left[\frac{1}{n_1^2} - \frac{1}{n_2^2} \right] \quad \Rightarrow \quad \nu = R c Z^2 \left[\frac{1}{n_1^2} - \frac{1}{n_2^2} \right]$$

where R is Rydberg's constant.

- Depending on the orbit in which transition occurs from higher orbits, there are different spectral series and they are named as follows:

- (i) **Lyman series** : $n_1 = 1, n_2 = 2, 3, \dots$ (in ultra-violet region)
- (ii) **Balmer series** : $n_1 = 2, n_2 = 3, 4, \dots$ (in visible region)
- (iii) **Paschen series** : $n_1 = 3, n_2 = 4, 5, \dots$ (in near infra-red region)
- (iv) **Brackett series** : $n_1 = 4, n_2 = 5, 6, \dots$ (in mid infra-red region)
- (v) **Pfund series** : $n_1 = 5, n_2 = 6, 7, \dots$ (in far infra-red region)
- **Comparative study of spectral series**
 - (i) As the order of spectral series increases, the wavelengths of lines increase.
 $\lambda_{\text{pFund}} > \lambda_{\text{Brackett}} > \lambda_{\text{Paschen}} > \lambda_{\text{Balmer}} > \lambda_{\text{Lyman}}$
 - (ii) The maximum number of spectral lines obtained due to transition of electrons present in n^{th} orbit is

$$N = \frac{n(n-1)}{2}.$$

- (iii) Frequency = c/λ .
 For λ_{max} , frequency is minimum.
 For λ_{min} , frequency is maximum.
- (iv) Energy = $hc/\lambda = h\nu$.
- **Bohr's formulae :**

- (i) *Radius* of n^{th} orbit $r_n = \frac{4\pi\epsilon_0 n^2 h^2}{4\pi^2 m Z e^2}$, $r_n = \frac{0.529 n^2}{Z}$ Å.

- (ii) *Velocity* of electron in the n^{th} orbit $v_n = \frac{1}{4\pi\epsilon_0} \frac{2\pi Z e^2}{nh} = \frac{2.2 \times 10^6 Z}{n}$ m/s.

- (iii) The *kinetic energy* of the electron in the n^{th} orbit

$$(K.E.)_n = \frac{1}{4\pi\epsilon_0} \frac{Z e^2}{2r_n} = \left(\frac{1}{4\pi\epsilon_0} \right)^2 \frac{2\pi^2 m e^4 Z^2}{n^2 h^2} = \frac{13.6 Z^2}{n^2} \text{ eV}.$$

- (iv) The *potential energy* of electron in n^{th} orbit

$$U_n = -\frac{1}{4\pi\epsilon_0} \frac{Z e^2}{r_n} = -\left(\frac{1}{4\pi\epsilon_0} \right)^2 \frac{4\pi^2 m e^4 Z^2}{n^2 h^2} = -\frac{27.2 Z^2}{n^2} \text{ eV}.$$

- (v) *Total energy* of electron in n^{th} orbit

$$E_n = U_n + (K.E.)_n = -\left(\frac{1}{4\pi\epsilon_0} \right)^2 \frac{2\pi^2 m e^4 Z^2}{n^2 h^2} = -\frac{13.6 Z^2}{n^2} \text{ eV}.$$

- (vi) *Frequency* of electron in n^{th} orbit $\nu_n = \left(\frac{1}{4\pi\epsilon_0} \right)^2 \frac{4\pi^2 Z^2 e^4 m}{n^3 h^3} = \frac{6.62 \times 10^{15} Z^2}{n^3}$

- (vii) *Wavelength* of radiation in the transition from $n_2 \rightarrow n_1$ is given by

$$\frac{1}{\lambda} = RZ^2 \left[\frac{1}{n_1^2} - \frac{1}{n_2^2} \right]$$

where R is called *Rydberg's constant*.

$$R = \left(\frac{1}{4\pi\epsilon_0} \right)^2 \frac{2\pi^2 m e^4}{ch^3} = 1.097 \times 10^7 \text{ m}^{-1}.$$

- **Ionisation energy** = $\frac{13.6Z^2}{n^2}$ eV.
- **Ionisation potential** = $\frac{13.6Z^2}{n^2}$ volt.
- In quantum mechanics, the energies of a system are discrete or quantised. The energy of a particle of mass m is confined to a box of length L can have discrete values of energy given by the relation

$$E_n = \frac{n^2 h^2}{8mL^2}; \quad n = 1, 2, 3, \dots$$

X-rays

- X-rays were discovered by Roentgen.
- X-rays are electromagnetic waves of wavelengths ranging from 0.1 Å to 100 Å.
- Harder X-rays have lower wavelength, high frequency, higher energy and greater penetration.

$$\text{Energy } E = \frac{hc}{\lambda} = h\nu.$$

- Softer X-rays have greater wavelength (λ), lower frequency (ν), lower energy (E) and smaller penetration.
- Frequency (ν) of X-rays range from 10^{16} Hz to 10^{18} Hz.
- X-rays are produced when fast moving electrons, accelerated by applying voltage, strike a metal of high atomic number.
- Molybdenum and tungsten provide suitable targets. These elements have large atomic number and high melting point for the purpose.
- A **Coolidge tube** provides a beam of electrons by process of thermionic emission.
- Greater the heating voltage applied, larger will be the number of thermions/electrons emitted from filament. Tungsten coated with oxide of Ba or Sr is a good source of thermions.
- Before collision with target, the electrons are accelerated by voltage V .

$$\text{Electric energy (eV)} = \text{K.E.} \left(\frac{1}{2} m v^2 \right).$$

- Energy of X-rays, produced as a result of collision between accelerated fast moving electrons and the target is given by $h\nu = \frac{hc}{\lambda}$.
- Assuming 100% energy transfer, $eV = h\nu = \frac{hc}{\lambda}$.

- Wavelength (λ) of X-ray emitted $\lambda = \frac{hc}{eV}$.

Thus $\lambda \propto 1/V$.

It is called **Daune-Hunt law**.

- Intensity of X-rays**

- For greater intensity/quantity of X-rays, number of striking electrons should be greater.
- More electrons are available if the voltage or current heating the filament is greater.
- Intensity of X-rays thus depend on filament current.
- The accelerating voltage V , across cathode and anticathode/anode, does not have any effect on intensity of X-rays.

- Quality/hardness of X-rays**

- Hardness/penetration power of X-rays is greater if X-rays possess greater energy or greater frequency or smaller wavelength.

$$E = h\nu = \frac{hc}{\lambda}$$

- X-rays gain greater energy if the colliding electrons have greater kinetic energy or greater velocity.
- The colliding electrons acquire greater speed and greater energy if they are accelerated by greater voltage across X-ray tube.

$$eV = \frac{1}{2}mv^2$$

- Thus quality/hardness of X-rays depends on accelerating voltage applied across X-ray tube.
- The heating voltage/current of the filament does not have any effect on quality of X-rays produced by Coolidge tube.

- Absorption of X-rays**

$$I = I_0 e^{-\mu x} \text{ where}$$

I_0 = initial intensity of X-rays

I = final intensity of emergent X-rays

x = thickness of material

μ = absorption coefficient

- Diffraction of X-rays**

X-rays can be diffracted by crystal following **Bragg's law**.

$$2d\sin\theta = n\lambda \text{ where } n = 1, 2, 3, \dots$$

and θ is the angle of diffraction, d = spacing of crystal planes.

- Efficiency of X-ray tube**

Only 0.2% of energy of incident electrons is used in producing X-rays. The remaining is converted into heat. A large cooling arrangement is required for anti-cathode.

Characteristic X-rays

- Characteristic X-rays relate to the material of target.
- When high energy electrons penetrate target atoms, they knock out electrons of inner orbits of the atoms. The vacancy thus created is filled by the jump of higher orbit electrons to lower orbit. The difference of energy of the two orbits is radiated as characteristic X-rays. This energy and therefore frequency of characteristic X-rays does not depend on the accelerating potential applied.

- The energy spectrum of characteristic X-rays is a line spectrum. There may be different series.
 - (i) **K-series** : When electrons of higher orbit $n = 2, 3, 4, \dots$ jump to first orbit $n = 1$, then K-series of X-rays are produced.
 - (ii) **L-series** : When electrons jump from $n = 3, 4, 5, \dots$ to $n = 2$, then L-series of X-rays are produced.
 - (iii) First line of the series is called $K_\alpha, L_\alpha, M_\alpha$. Second line of the series is called $K_\beta, L_\beta, M_\beta$. Third line is designated as K_γ, L_γ and M_γ .
- **Mosley's law**
 $\nu = a(Z - b)^2$ where a and b are constant and Z is atomic number of element. ν represents frequency of line.
 Thus $\nu \propto Z^2$ or $\sqrt{\nu} \propto Z$ for characteristic X-rays.

Nuclei

- The atoms of an element which have the same atomic number but different mass number are called **isotopes**.
- The atoms of an element whose nuclei have same number of neutrons are called **isotones**.
- The atoms of same mass number but different atomic number are called **isobars**.
- Atoms having the same mass number and the same atomic number but different radioactive properties are called **isomers**.
- **Nucleus of an atom**
 - (i) Rutherford discovered nucleus.
 - (ii) Protons and neutrons reside in a nucleus. Protons denote charge on nucleus. Protons have positive charge. Charge on nucleus = Ze where Z protons lie in nucleus.
 Mass of nucleus is due to protons and neutrons. Electrons do not lie in the nucleus.
 - (iii) Density of nucleus = $10^{14} \text{ g/cm}^3 = 10^{17} \text{ kg/m}^3$.
 - (iv) Radius of nucleus = $r_0 A^{1/3}$ where $r_0 = 1.2 \times 10^{-15} \text{ m}$.
 Radius of nucleus $\approx 10^{-15} \text{ m}$.
 - (v) Nucleon = neutron + proton inside the nucleus.
- **Mass defect (Δm)**
 $\Delta m = \text{mass of (neutron + proton - nucleus)}$
 $\Delta m = N M_n + Z M_p - M_{ZA}$ where
 N = number of neutrons in nucleus
 Z = number of protons in nucleus
 M_n = mass of one neutron, M_p = mass of one proton
 M_{ZA} = mass of nucleus formed.
 Δm = decrease in mass during the process of formation of nucleus.
- **Binding energy (ΔE)**
 - (i) ΔE = energy obtained by converting Δm in energy.
 $\Delta E = (\Delta m)c^2 = (NM_n + ZM_p - M_{ZA})c^2$
 - (ii) Binding energy represents the stability of nucleus.
 - (iii) Energy equivalent of a nucleon = 931 MeV
 Energy due to 1 proton = energy due to 1 neutron
 $\Rightarrow 1 \text{ a.m.u} = (1.67 \times 10^{-27}) \times c^2$

$$= \left(\frac{5}{3} \times 10^{-27}\right) \times (3 \times 10^8)^2 \text{ J}$$

$$\Rightarrow 1 \text{ a.m.u} = \frac{5 \times 9 \times 10^{-27} \times 10^{16}}{3} \text{ J}$$

$$\Rightarrow 1 \text{ a.m.u} = \frac{15 \times 10^{-11}}{1.6 \times 10^{-19}} \text{ eV} = \frac{15}{16} \times 10^9 \text{ eV} = 931 \text{ MeV.} \quad \Rightarrow 1 \text{ a.m.u} = 931 \text{ MeV.}$$

$$(iv) \text{ Binding energy per nucleon} = \frac{\Delta E}{A}$$

- **Packing fraction (P)** : The difference between the exact nuclear mass M of a nucleus and its mass number A , divided by the mass number.

$$P = \frac{M - A}{A}$$

- **Nuclear forces**

- The forces which keep neutrons and protons bound inside the nucleus are known as nuclear forces.
 - These are short range forces.
Range $\approx 10^{-15} \text{ m} \approx$ size of nucleus
 - These forces are attractive and spin dependent. They do not depend on charge. They are not like Coulomb forces.
 - These forces act alike between $p-p$, $n-n$, $n-p$ and $p-n$.
 - At distances less than nuclear range, these forces become repulsive.
- **Natural radioactivity** is the phenomenon of emission of active radiation by heavy nuclei. The emission is spontaneous.
 - The radioactive radiations are of three types; α -rays, β -rays and γ -rays. An α -particle carries two units of positive charge and four units of mass. A β -particle carries unit negative charge and has negligible mass. A γ -ray carries no charge and has zero rest mass.
 - α -particles are the same as He nuclei. β^- particles are electrons and β^+ are positrons. γ -rays are electromagnetic radiations emitted by excited states of nuclei.
 - The emission of an α -particle by a radioactive atom results in a daughter atom, whose atomic number is 2 units less and mass number is 4 units less than that of the parent atom.

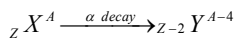

- The emission of a β -particle by a radioactive atom results in a daughter atom, whose atomic number is 1 unit more but mass number is same as that of the parent atom

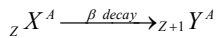

- Radioactive decay law

$$\Rightarrow \frac{dN}{dt} = -\lambda N \text{ where } \lambda = \text{decay constant or disintegration constant of radioactive atom.}$$

$$\Rightarrow N = N_0 e^{-\lambda t}$$

where N_0 = number of atoms initially present in sample ($t = 0$).

- The time during which half the number of atoms present initially in a radioactive element decay is called **half-life**. It is represented by $T = 0.693/\lambda$
- **Average life** or mean life of a radioactive element is given by $\tau = \frac{1}{\lambda} = 1.44T$.
- The number of atoms left undecayed after n half lives

$$N = N_0 \left(\frac{1}{2}\right)^n \text{ or, } N = N_0 \left(\frac{1}{2}\right)^{t/T}, \text{ where } t = nT.$$

After t second, $N = N_0 e^{-t/\tau}$.

- The activity of radioactive substance may be defined as the rate at which the nuclei of its atoms in the sample disintegrate. The practical unit of activity of a radioactive sample is curie (Ci)

$$1 \text{ curie (Ci)} = 3.7 \times 10^{10} \text{ disintegration s}^{-1}$$

Nuclear fission

- A heavy unstable nucleus breaks into two smaller parts. An energy of about 200 MeV is released and 3 neutrons are emitted when ${}_{92}\text{U}^{235}$ splits by the impact of a slow neutron.

$${}_{92}\text{U}^{235} + {}_0n^1 = {}_{92}\text{U}^{236} = {}_{56}\text{Ba}^{141} + {}_{36}\text{Kr}^{92} + 3({}_0n^1) + 200 \text{ MeV}$$
- Atom bomb is based on nuclear fission.
- About 99.9% of energy is converted into heat. Rest is converted into kinetic energy of neutrons, γ -rays, light and product nuclei.
- **Nuclear reactor** : It is the furnace in which energy is generated by controlled nuclear fission.
 - Fuel** - The material like ${}_{92}\text{U}^{235}$, ${}_{92}\text{U}^{238}$, ${}_{94}\text{Pu}^{239}$ which can undergo fission by a neutron is known as fuel.
 - Moderator** - The material like heavy water, graphite and beryllium oxide which can retard and control the fast moving neutrons is called moderator.
 - Coolant** - The material like cold water, cold air current, heavy water, liquid oxygen which can absorb the heat generated is known as coolant.
 - Control rods** - The rods of material like cadmium, which can control the rate of chain reaction are called control rods.
 - Controlled chain reaction is slow and needs only one neutron for further fission, on which control is possible. Atomic reactors work on the basis of controlled chain reaction.
 - Uncontrolled chain reaction is fast and needs more than one neutron for further fission. Atom bomb is an example. It cannot be controlled once the fission starts.

Nuclear fusion

- Two or more than two lighter nuclei combined to form a heavy nucleus with liberation of energy constitute **nuclear fusion**.

$$4({}_1\text{H}^1) = {}_2\text{He}^4 + 2({}_{+1}e^0) + 2\nu + 27 \text{ MeV}$$
- Temperature should be high about 10^7 K.
- Pressure should be large about 10^6 atmosphere.
- The kinetic energy of interacting nuclei must be greater than the Coulomb repulsive energy *i.e.* about 0.1 MeV.

- Hydrogen bomb is based on fusion.
- **Thermonuclear energy** : The energy released during nuclear fusion is known as thermonuclear energy.
- Protons are needed for fusion while neutrons are needed for fission process.
- Fusion reactors are better than fission reactors because harmful radiations are not produced in them.
- **Proton-proton cycle** : This cycle is the source of energy in the Sun.

$$4\ ({}_1\text{H}^1) \rightarrow {}_2\text{He}^4 + 2\ ({}_{+1}\text{e}^0) + 2\nu + 27\ \text{MeV}$$
 Temperature in Sun = $1.5 \times 10^7\ \text{K}$
- **Carbon-nitrogen cycle** : This cycle occurs in stars bigger than sun at temperature = $2 \times 10^7\ \text{K}$.

$$4\ ({}_1\text{H}^1) \rightarrow {}_2\text{He}^4 + 2\ ({}_{+1}\text{e}^0) + 2\nu + \text{energy}$$

Carbon dating

- Carbon dating is used to find the age of archeological samples and the plant etc.
- All the live plants and bones of animals have C^{14} which is in equilibrium with C^{14} in the atmosphere and remain constant as long as plant or animal is alive, but after the same dies, radio carbon C^{14} continues to disintegrate and the number of disintegration per minute decreases with time. Thus the time taken by C^{14} to decay when the plant or animal died and ceased to assimilate C^{14} can be easily estimated.

End

solids and semiconductor devices

- The solids in which the atoms are arranged in a definite, regular and long range order are said to be **crystalline**; Otherwise if the atoms are arranged in indefinite, irregular and short range order, they are called **amorphous**.
- Amorphous substances are termed as glassy substances, since glass is an amorphous solid.
- Crystalline solids are bounded by flat surfaces and possess uniform chemical composition while the distribution of atoms or molecules in amorphous solids are random and they are not bounded by flat surface.
- Crystalline solids are anisotropic *i.e.* the physical properties like thermal conductivity, electrical conductivity, compressibility etc. have different values in different directions, while amorphous solids are isotropic.
- Crystalline solids have a sharp melting point *i.e.* change of solid occurs suddenly while the amorphous solids do not have this because the bonds between all the atoms and molecules are not of equal strength.
- Below the temperature of crystallisation, the crystalline solids are in a stable state, since a stable state is the state of minimum energy, such a material acquires a state of minimum energy on crystallisation.
- The molecular crystals are solid at low temperature because of the van der Waal's force arising out of polarisation. The infinite array of atoms or molecules in space such that each of the atom or molecule possesses identical surroundings is called **crystal lattice**.
- The smallest geometrical block consisting of one or more atoms from which whole of the crystal lattice may be built by translating the block, parallel to itself in all directions is called the unit cell.
- **Monocrystal** is a crystal in which the ordered arrangements of the atoms or molecules extends throughout the piece of solid, irrespective of its size.
- **Polycrystal** is a crystalline solid in which each piece of the solid has a number of monocrystals with developed faces joined together.
- Some organic crystalline solids, when heated acquire fluidity but retain their anisotropic properties. They are called **liquid crystals**.
- Some liquid crystals like cyanobiphenyl can change the plane of polarisation of light and such liquid crystal displays (LCD) are used in watches and microcalculators.
- The polycrystal ceramic made from PbO , ZnO_2 and TiO_2 are used in gas lighters, and telephone receivers.

- Unit cell is building block of the crystal lattice. Unit cell is the smallest unit of the crystal lattice, repetition of which in three dimensions gives rise to a crystal lattice.
- The lengths of three sides of a unit cell are called primitives or lattice constant represented by a, b, c . The angle between three crystallographic axis (meeting at a point) are called interfacial angles, represented by α, β and γ . The primitives and interfacial angles constitute the lattice parameters of a unit cell.
- The cubic crystals may be of the form, simple cubic lattice (sc), the body centred cubic lattice (bcc), the face centred cubic lattice (fcc).
- The number of atoms in a crystal which surrounds a particular **atom as its nearest neighbours is called** co-ordination number.
- The atomic radius is the distance between the centres of two neighbouring atoms.
- Atomic packing factor is the ratio of the volume occupied by the atoms in a unit cell to the volume of the unit cell.
- Density of a crystalline solid is defined as the ratio of the mass of the unit cell to the volume of the unit cell.
- The minimum amount of energy which must be given to an electron so that it may escape from the metallic surface is called the work function of that surface.
- When a very intense electric field, say 10^6 volt/cm is applied such as to make a metal surface negative with respect to the space around it, then some of the free electrons, are accelerated away from the surface. This is known as field emission or cold emission.
- Photo electric emission occurs when electrons are emitted from metal surface on irradiating them with radiation of suitable frequency.
- When a highly energetic electron strikes the surface of a metallic plate it usually causes the emission of other electrons from the surface. The electron striking the surface is called primary electron, while those emitted from the surface are called secondary electrons. This phenomenon is known as secondary emission.
- **Thermionic emission** occurs when a metal is heated to a high temperature, the free electrons in the metal gain kinetic energy sufficient to escape through the surface of the metal.
- The electron emission from the cathode of thermionic valve depends on the temperature of the filament and the work function of the material of the cathode.
- The thermionic diode is a two electrode (cathode and plate) device based on thermionic emission.
- A diode allows unidirectional flow of electrons, i.e. only when the plate is positive with respect to cathode. Hence it is also called a valve.
- The plate resistance of diode (R_p) is defined as the ratio of change in plate potential to the corresponding change in plate current. *i.e.* $R_p = \frac{\Delta V_p}{\Delta I_p}$.
- The triode valve consists of three electrodes e.g. cathode, plate and grid enclosed in an evacuated glass bulb.
- Grid influences the space charge and controls the flow of plate current.

- When the grid is given a negative potential with respect to cathode, it repels the electrons escaping from the cathode and increases the effect of space charge, at sufficiently negative grid potential the plate current falls to zero. This value of grid potential is known as **cut off grid bias**.
- If the grid is given a positive potential with respect to cathode, it attracts the electrons and decreases the effect of space charge, increasing the plate current. In this case a current flows into the circuit, thus grid modifies the function of valve.
- Grid is always kept at small negative potential with respect to cathode.
- The two important characteristics of the triode valves are (i) plate or anode characteristics and (ii) mutual characteristic curves.
- The principal effect of the negative space charge in a vacuum tube is to decrease the plate current.
- On making grid voltage excessively negative the plate resistance R_p becomes infinite.
- The output of a rectifier circuit is pulsating voltage which is a mixture of an a.c. component and a d.c. component. The circuit used to eliminate a.c. from d.c. voltage is called filter.
- The static amplification factor of a triode valve depends upon relative positions of cathode, grid and plate.
- The amplification factor of a triode valve is defined as the ratio of a small change in plate potential to a change in grid potential in the opposite direction, so that the plate current remains constant.
- The mutual conductance or transconductance (g_m) of triode valve is defined as the ratio of small change in plate current to the corresponding change in grid potential.
- The characteristics of a valve in presence of load are called dynamic characteristics of the valve.
- The load line is a graphical representation of the distribution of the plate supply voltage across the load and across the internal plate resistance of the valve.
- Triode can be used as an amplifier, oscillator, modulator and demodulator.
- The amplifying action of the triode is based on the fact that a small change in grid voltage causes a large change in plate current.
- An oscillator is an electronic device which generates a.c. voltage from d.c. power. It is basically a positive feedback amplifier with infinite voltage gain.
- **Band theory of solids** : A solid is a large collection of atoms. The energy levels of an atom get modified due to the presence of other surrounding atoms and the energy level in the outermost shells of all the atoms form valence band and the conduction band separated by a forbidden energy gap.
- The minimum energy required by an electron to jump from valence band to the conduction band is equal to the magnitude of the energy of the forbidden energy gap.
- The highest energy level, which an electron can occupy in the valence band at 0 K is called Fermi level.

- In metals, the valence and conduction band overlap on each other or there is not forbidden gap.
- In insulators, the valence band is completely filled with electrons and the conduction band is empty and both the bands are separated by forbidden energy gap of about 6-7 eV. Since this much of energy cannot be provided conveniently, so no electron from valence band can go to conduction band, hence insulator is a bad conductor of electricity.
- In semiconductors the forbidden gap between the valence band and the conduction band is very small. **Semiconductor** behaves as an insulator at 0 K. The resistance of the semiconductor decreases with rise in temperature hence conductivity increases.
- The conduction electrons have higher mobility than the holes because they need less energy to move.
- The hole is created when valence band electrons jump to conduction band.
- Pure germanium and silicon crystals in their natural state are called intrinsic semiconductors. In intrinsic semiconductors, $n_e = n_h = n_i$, where n_e , n_h and n_i are number density of electron, holes and intrinsic carriers respectively.
- Addition of suitable impurities to intrinsic semiconductors in order to increase their conductivity is known as doping.
- Doping materials are called impurities. Doped semiconductors are called extrinsic semiconductors. The dopants (impurity atoms) may be of the order of 1 in 10^{10} atoms.
- **N-type semiconductor**
 - (i) Germanium and silicon, the intrinsic semiconductors, are tetravalent.
 - (ii) When impurity of some pentavalent elements like P, As, Sb, Bi etc is mixed in a controlled manner, N-type semiconductors are produced.
 - (iii) The impurity atom donates one electron. Hence the semiconductor is called donor type semiconductor.
 - (iv) The Fermi energy level lies close to conduction band. Thus the Fermi energy lies in between the donor energy level and conduction band. The donor energy level is close to conduction band and far away from valence band.
- **P-type semiconductor**
 - (i) Intrinsic or pure semiconductors are tetravalent elements.
 - (ii) When impurity of some trivalent elements like B, Al, In, Ga etc. is mixed in a controlled manner, P-type semiconductors are prepared.
 - (iii) The impurity atom can accept one electron. Hence the semiconductor is called acceptor type semiconductor.
 - (iv) The acceptor energy level is close to the valence band and far away from conduction band. The Fermi energy level lies close to the valence band in between the acceptor energy level and valence band.

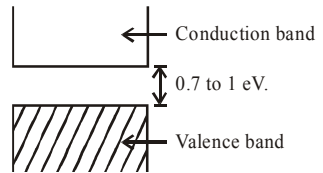
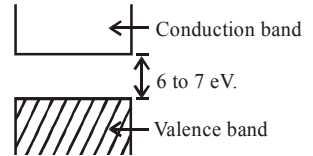
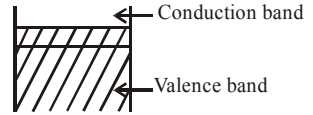

- In *N*-type semiconductor, the number of density of electrons is approximately equal to that of donor atoms and very large as compared to number density of holes. Thus $n_e \approx n_d \gg n_h$
- The number density of holes in *P*-type semi conductor is approximately equal to that of acceptor atoms and is very large as compared to number density of electrons. Thus $n_h \approx n_a \gg n_e$.
- Number densities of majority and minority carriers in extrinsic semiconductor. $n_e n_h = n_i^2$.
- The majority carriers in a semiconductor are holes in *P*-type and electrons in *N*-type.
- The drift velocity of electrons is expected to be greater than holes.
- Junction diode is a semiconducting device equivalent to diode valve. It is formed by placing a *P*-type crystal in contact with *N*-type crystal and subjecting to high pressure so that it becomes a single piece.

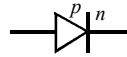

- Diffusion of holes and electrons causes the depletion layer across the *P-N* junction.
- The potential difference developed across the junction is called potential barrier.
- When a battery is connected to the diode with *P*-section connected to positive pole and *N*-section to the negative pole, the junction diode is said to be forward biased, whose characteristic is explained by graph.

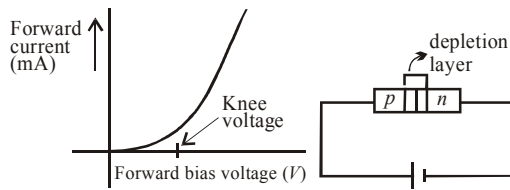

- When a battery is connected to the junction diode with *P*-section connected to the negative pole and *N*-section connected to the positive pole, the junction is said to be reverse biased. Reverse bias characteristic is explained by graph.

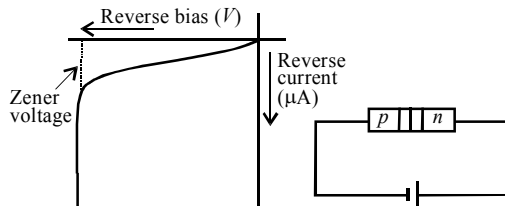

- The current in a *P-N* junction is given by $I = I_0 (e^{eV/k_B T} - 1)$ where I_0 is reverse saturation current, V is potential difference across the diode, k_B is the Boltzmann constant.
- If the reverse bias is made very high, the covalent bonds near the junction break down and a large number of electron hole pairs are liberated. The reverse current then increases abruptly to a relatively large value. This is known as **Avalanche break down**.

- The maximum voltage that a junction diode can bear without break is called **zener voltage** and the junction diodes possessing this voltage is known as **Zener diode**.
- When a junction diode is forward biased, energy is released at the junction due to recombination of electrons and holes. In case of silicon and germanium diodes the energy released is in infra red region, while in the junction diode made of gallium arsenide or indium phosphide, the energy is released in visible region. Such a junction diode is

called light emitting diode or LED. It is denoted by 

- The electrons as well as hole mobility decreases with the increase in temperature.
- The value of potential barrier depends on the doping of the semiconductor.
- The width of the potential barrier is of the order of 0.01 mm. It opposes the forward current and also opposes the reverse current.
- The depletion region widens during the reverse bias and so it offers high resistance, while becomes thin during forward bias and offers less resistance.
- In an ideal diode the forward bias offers zero resistance and acts as a short circuit. Voltage drop across such a diode is also zero.
- A device which converts alternating current (or voltage) into direct current (or voltage) is called rectifier. The process of converting a.c. into d.c. is called **rectification**.
- Half wave rectifier converts only one half of a.c. into d.c. while full wave rectifier rectifies both halves of a.c. input.

Half-wave rectifier

- A half-wave rectifier converts half cycle of applied A.C. signal into D.C. signal.
- The value of $I_{\text{rms}} = I_0/2$
- $I_{\text{dc}} = I_0/\pi$

- Form factor = $\frac{I_{\text{r.m.s}}}{I_{\text{dc}}} = \frac{I_0}{2} \times \frac{\pi}{I_0} = \frac{\pi}{2} = 1.57$

- Efficiency (η) = $\frac{40.6}{\left[1 + \frac{r_d}{R_L}\right]}$

(i) When $r_d = R_L$, efficiency (η) = 20.3%

(ii) When $r_d \ll R_L$, efficiency (η) = 40.6%

- The rectifier uses one diode or one semiconductor diode.
- Ordinary transformer may be used here.

Full-wave rectifier

- A full-wave rectifier converts the whole cycle of applied A.C. signal into D.C. signal.

- The value of $I_{\text{rms}} = \frac{I_0}{\sqrt{2}}$

- $I_{\text{dc}} = \frac{2I_0}{\pi}$

- Form factor = $\frac{I_0/\sqrt{2}}{2I_0/\pi} = \frac{\pi}{2\sqrt{2}} = 1.11$

- Efficiency (η) = $\frac{81.2}{\left[1 + \frac{r_d}{R_L}\right]}$

(i) When $r_d = R_L$, $\eta = 40.6\%$

(ii) When $r_d \ll R_L$, $\eta = 81.2\%$.

- The rectifier uses two diodes or one double diode or two junction diodes.
- Centre tap transformer is used here.

Transistor

- A junction transistor is a semiconductor device which is obtained by growing a thin layer of one type semiconductor in between two thick layers of other similar type semiconductor *i.e.* the semiconductor device is having two junctions and three terminals.

- N-P-N transistor or n-p-n transistor:*** If the central thin layer is of *P*-type and outer thick layers are of *N*-type semiconductor, the transistor is of *N-P-N* configuration.

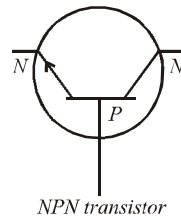

- P-N-P transistor or p-n-p transistor:*** If the central thin layer is of *n*-type and outer thick layers are of *P*-type semiconductor, the transistor is of *P-N-P* configuration.

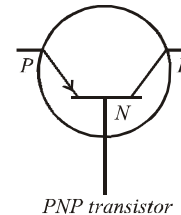

- The thin layer of junction transistor is known as base (*B*). One of the thick layers serves as emitter (*E*) and the other thick layer serves as collector (*C*).
- The base of a transistor is made thin and as it is comparatively lightly doped, the number of density of majority carriers in the base is always lesser compared to that in emitter or collector.
- The emitter of a transistor is doped the heaviest because it is a supplier of charge carriers.
- The function of emitter is to emit the majority carriers. The collector collects the majority carriers. The base provides the proper interaction between the emitter and the collector.
- A transistor is preferable to triode valve because it does not require a heater and hence efficiency is higher.
- The ratio of change in collector current to the change in emitter current for a constant value of collector voltage in a common base arrangement is current gain.
- Relation between the current gain of common base and common emitter amplifier.

$$\beta = \frac{\alpha}{1-\alpha} = \frac{I_C}{I_B}$$

- Voltage and power gains in common-emitter amplifier are much greater than the voltage and power gain in common base amplifier, so common-emitters prepared over a common-base amplifier.
- The current gain of common base transistor is less than 1.
- **Comparison of CB and CE amplifiers**
CB means common base and CE means common emitter.

S.No.	Parameter	CB amplifier	CE amplifier
1.	Input resistance	50 - 200 Ω	1-2 k Ω
2.	O u t p u t resistance	1-2 M Ω	\approx 50 k Ω
3.	Current gain	$\alpha = 0.8$ to 0.9 It is less than 1	$\beta \approx 20$ to 200
4.		medium	high
5.	Voltage gain	medium	maximum
6.	Power gain Phase difference	zero. The input and the output voltages are in phase.	π or 180° . The input and output voltages are in opposite phases.
7.	D.C. current gain	$\alpha = \frac{I_c}{I_e}$	$\beta = \frac{I_c}{I_b}$
8.	A.C. current gain	$\alpha_{a.c.} = \frac{\Delta I_c}{\Delta I_e}$	$\beta_{a.c.} = \frac{\Delta I_c}{\Delta I_b}$
9.	A.C. voltage gain	$A_v = \frac{\Delta V_c}{\Delta V_i} = \alpha_{a.c.} \times \frac{R_0}{R_i}$	$A_v = \beta_{a.c.} \times \frac{R_0}{R_i} = -g_m \times R_0$
10.	A.C. power gain which is ratio of change in output power to change in input power	A.C. power gain $= \alpha_{a.c.}^2 \times \frac{R_0}{R_i}$ $= \alpha_{a.c.} \times A_v$	A.C. power gain $= \beta_{a.c.} \times A_v$

Digital electronics and logic gates

- In the digital electronics, we make use of two types of logic system : Positive logic and negative logic. In the positive logic 0 stands for lower (say voltage) level and 1 stands for higher level. In the negative logic 0 stands for higher (say voltage) level and 1 stands for lower level.
- A signal which can have only discrete value is called digital signal.
- The **binary number system** is a code that uses only two digits 0 and 1.
- Boolean expression for OR gate is $Y = A + B$ where A and B are two inputs.

For AND gate $Y = A \cdot B$

For NOT gate $Y = \bar{A}$, means Y is inverse of A .

- Truth table of a logic gate is a table that shows all the input output possibilities for the logic gate

Symbol of OR gate

Truth table of OR gate

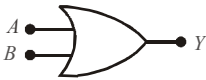

A	B	$Y = A + B$
0	0	0
0	1	1
1	0	1
1	1	1

Symbol of AND gate

Truth table of AND gate

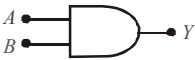

A	B	$Y = A \cdot B$
0	0	0
0	1	0
1	0	0
1	1	1

Symbol of NOT gate

Truth table of NOT gate

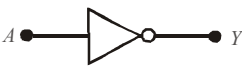

A	$Y = \bar{A}$
0	1
1	0

- **Other gates**

(i) **NAND gate** : It is obtained when the output of AND gate is applied to the input of NOT gate. Boolean expression for NAND gate is $Y = \overline{A \cdot B}$.

Symbol of NAND gate

Truth table

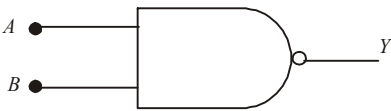

A	B	Y
0	0	1
1	0	1
0	1	1
1	1	0

(ii) **NOR gate** : It is obtained when the output of OR gate is applied to the input of NOT gate.

Boolean expression for NOR gate is $Y = \overline{A + B}$.

Symbol of NOR gate

Truth table

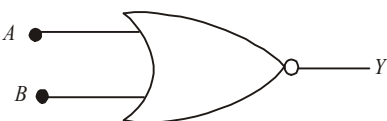

A	B	Y
0	0	1
1	0	0
0	1	0
1	1	0

- **De-Morgan's theorems**

(i) $\overline{A+B} = \bar{A} \cdot \bar{B}$

(ii) $\overline{A \cdot B} = \bar{A} + \bar{B}$

Salient points about semiconductors, transistors and logic gates

- In order to obtain the oscillations of a constant amplitude, an arrangement is made for positive feed back from an output circuit to the input circuit. The transistor then acts as an oscillator.
- In a common base transistor amplifier:
 - (i) The input and output signals are in the same phase.
 - (ii) There is no amplification in current of a given signal.
 - (iii) There is an amplification in voltage and power of the given signal.
- In a common emitter transistor amplifier:
 - (i) The input and output signals are out of phase by π or 180° .
 - (ii) There is amplification in current, voltage and power of the given signal.
- A transistor can be used as amplifier and oscillator but not as a rectifier.
- An ideal junction diode offers zero resistance when forward biased. Voltage drop across such a diode is zero.
- An ideal junction diode offers infinite resistance when reverse biased. It acts as an open circuit.
- The Boolean expressions obey commutative law, associative law as well as distributive law *i.e.*
 - (i) $A + B = B + A$
 - (ii) $A \cdot B = B \cdot A$
 - (iii) $A + (B \cdot C) = (A + B) \cdot C$

End

principles of communication

Three parts of a communication system

- A communication system used electrical, electronic and optical modes for transmission of information from one place to another. It consists of the following three parts:
 1. Transmitter
 2. Communication channel
 3. Receiver

Transmitter

- A transmitter transmits the information or message signal after modifying it into a form suitable for transmission.
- The message signal for communication can be analog signals or digital signals.
- An analog signal is that in which current or voltage value varies continuously with time.
- A digital signal is a discontinuous function of time. Such a signal is usually in the form of pulses.
- An analog signal can be converted suitably into a digital signal and vice-versa.
- **Modulation** : The message signal cannot travel over long distances. They are superimposed on a high frequency wave known as carrier wave.
- The power of modulated signal is boosted using a suitable amplifier.
- The amplified signal is radiated into space with the help of transmitting antenna.

Communication channel

- The communication channel carries the modulated wave from the transmitting antenna to the receiving antenna.

Receiver

- In the wireless (radio) communication the receiver consists of the following parts:
 - (i) A pick up antenna.
 - (ii) A demodulator - It is reverse of modulator.
 - (iii) An amplifier
 - (iv) The transducer

A transducer is a device which converts a message signal into electrical signal and vice-versa. Broadly it converts one form of energy into another. A transducer has either input or output in electrical form.

Electromagnetic waves

- Electromagnetic waves are those waves in which there is a sinusoidal variation of electric and magnetic field vectors at right angles to each other as well as at right angles to the direction of propagation of wave.
- Both the field vectors \vec{E} and \vec{B} of the electromagnetic wave vary with time and space and have the same frequency and same phase.
- Electromagnetic waves can travel through vacuum with the speed of light *i.e.* $3 \times 10^8 \text{ ms}^{-1}$.
- The energy is shared equally between electric field and magnetic field of electromagnetic waves.

Earth's atmosphere

The various regions of earth's atmosphere are :

- **Troposphere** - It extends upto a height of 12 km.
- **Stratosphere** - It extends from 12 km to 50 km.
- There is an ozone layer in stratosphere.
- **Mesosphere** - It extends from 50 km to 80 km.
- **Ionosphere** - It extends from 80 km to 400 km. It is composed of ionised matter *i.e.* electrons and positive ions. It plays an important role in space communication.
- **Frequency ranges** : The various frequency ranges used in radiowaves or microwave communication system are shown below:
 - (i) Medium frequency band (M.F.) 300 to 3000 kHz.
 - (ii) High frequency band (H.F.) 3 to 30 MHz.
 - (iii) Very high frequency band (V.H.F.) 30 to 300 MHz.
 - (iv) Ultra high frequency band (U.H.F.) 300 to 3000 MHz.
 - (v) Super high frequency band (S.H.F.) 3000 to 30,000 MHz.
 - (v) Extra high frequency band (E.H.F.) 30 to 300 GHz.

Modes of propagation of radio waves

- **Ground wave propagation** : It is suitable for low and medium frequency *i.e.* upto 2 MHz only.
- **Sky wave propagation** : The sky waves are the radio waves of frequency between 2 MHz to 30 MHz. These waves can propagate through atmosphere and are reflected by the ionosphere of earth's atmosphere.
- **Space wave propagation** : The space waves are radio waves of very high frequency *i.e.* between 30 MHz to 300 MHz or more. The space wave communication is utilized in television communication, radar communication and microwave communication. Television signals have the frequency range 80 MHz to 200 MHz.
- **Microwave propagation:**
 - (i) Microwaves are electromagnetic waves of frequency 100 to 300 GHz, greater than those of T.V. signals. The wavelength of microwaves is of the order of a few mm.
 - (ii) These waves can be transmitted as beam signals in a particular direction, much better than radiowave.

- (iii) Microwave communication is used in radars to locate the flying objects (like aeroplane) in space.
- (iv) There is no diffraction of microwave around corners of an obstacle which happens to lie along its passage.
- **Satellite communication**
 - (i) A satellite communication is possible through geo-stationary satellites. At least three geo-stationary satellites are required which are 120° apart from each other, to cover the entire globe of earth.
 - (ii) The satellite communication is a mode of communication and receiver through satellite.
 - (iii) A communication satellite is a space craft, provided with microwave receiver and transmitter. It is placed in an orbit around the earth.
- **Remote sensing**
 - (i) Remote sensing is done through a satellite. The satellite moves in a fixed orbit around the earth in a way such that it passes over a given location on the earth at the same local time. The orbit of such a satellite is known as Sun-synchronous orbit.
 - (ii) Such satellites provide us with data critical to weather production, agriculture forecasting, resource exploration and environmental monitoring.
 - (iii) The India remote sensing satellites are IRS-IA, IRS-IB and IRS-IC.
 - (iv) Such satellite takes repeated photographs of the particular location of the earth during its repeated journeys over that location. The comparative study of photographs leads to required results.

Optical fibres

- An optical fibre is a long thread consisting of a central core of glass or plastic of uniform refractive index. It is surrounded by a cladding of material of refractive index less than that of the core and a protective jacket of insulating material.
- There are three types of optical fibre configuration:
 - (i) Single-mode step-index fibre.
 - (ii) Multi-mode step-index fibre.
 - (iii) Multi-mode graded-index fibre.
- **Critical angle** : It is that angle of incidence in the denser medium for which the angle of refraction in rarer medium is 90°.

$$\therefore \frac{\mu_1}{\mu_2} = \frac{\sin \theta_C}{\sin 90^\circ} = \sin \theta_C$$

If the rarer medium is air, $\mu_1 = 1$

$$\therefore \mu_2 = \frac{1}{\sin \theta_C}$$

In optical fibre, critical angle is given by

$$\cos \theta_c = \frac{\sqrt{\mu_1^2 - \mu_2^2}}{\mu_1}$$

- Optical fibres are used in optical communication.

- The optical communication system is more economical than other systems of communications and it has larger information carrying capacity and provides high quality service.
- Optical fibre cables are of small size and weight as compared to metallic cables and hence occupy small space for its operation.
- Optical fibres are most suitable for digital transmission and switching system.

LED and diode lasers in communication

- Light emitting diode (LED) and diode lasers are preferred sources for optical communication links to the following features.
 - (i) Each produces light of suitable power required in optical communication.
 - (ii) Diode laser provides light which is monochromatic and coherent. This light is obtained as a parallel beam. It is used in very long distance transmission.
 - (iii) LED provides almost monochromatic light. This is suitable for small distance transmission. It is, in fact, a low cost device as compared to diode lasers.

Line communication

- Transmission lines are used to interconnect points separated from each other. For example interconnection between a transmitter and a receiver or a transmitter and antenna or an antenna and a receiver are achieved through transmission lines.
- The most commonly used two wire lines are
 - (i) parallel wire lines
 - (ii) twisted pair wire lines
 - (iii) coaxial wire lines
- Parallel wire lines are never used for transmission of microwaves. This is because at the frequency of microwaves, separation between the two wires approaches half a wavelength (*i.e.* $\lambda/2$). Therefore, radiation loss of energy becomes maximum.
- Primary constants of a transmission line
 - (i) The four line parameters are resistance (R), inductance (L), capacitance (C) and conductance (G).
 - (ii) Series impedance (Z) = $R + j\omega L$
 - (iii) Shunt admittance (Y) = $G + j\omega C$.

End

practical physics

1. VERNIER CALLIPERS - It is used to measure internal and external diameter and depth of a vessel

- A vernier callipers is an instrument that is used to measure distances correctly upto 0.1 mm or 0.01 cm. The diagram of vernier callipers is shown below.

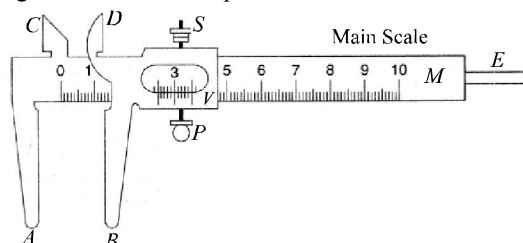

- Vernier callipers has a main scale M (in millimetres), a sliding vernier scale V , fixed jaws A and C , movable jaws B and D projected at right angles to the main scale and a thin metallic strip E attached to the back side of M and connected with vernier scale.

- Vernier constant or least count of a vernier**

The difference between the values of one main scale division and one vernier scale division is known as vernier constant. This is the smallest distance that can be accurately measured with the vernier scale. So, it is called least count of vernier scale.

Let n vernier scale division (V.S.D.) coincide with $(n - 1)$ main scale division (M.S.D.)

$$\therefore n \text{ V.S.D.} = (n - 1) \text{ M.S.D.}$$

$$1 \text{ V.S.D.} = \left(\frac{n-1}{n}\right) \text{ M.S.D.}$$

$$\text{Vernier constant, V.C.} = 1 \text{ M.S.D.} - 1 \text{ V.S.D}$$

$$\text{Vernier constant} = 1 \text{ M.S.D.} - \left(\frac{n-1}{n}\right) \text{ M.S.D.}$$

$$= \frac{1}{n} \text{ M.S.D}$$

$$= \frac{\text{Smallest division on main scale}}{\text{No. of divisions on vernier scale}}$$

- Reading a vernier scale**

If the zero of vernier scale lies ahead of N^{th} division of main scale, then main scale reading (M.S.R) is N .

If n^{th} division of the vernier scale coincides with any division of main scale, then vernier scale reading (V.S.R.) is $n \times \text{V.C.}$

where n = coinciding division of vernier scale.

$$\begin{aligned} \therefore \text{Total reading (T.R.)} &= \text{M.S.R.} + \text{V.S.R} \\ &= N + n \times (\text{V.C.}) \end{aligned}$$

- **Zero error and zero correction**

Zero error : If the zero of the vernier scale does not coincide with the zero of the main scale, then the instrument has an error called zero error.

Zero correction : It has a magnitude equal to zero error but its sign is opposite to that of zero error.

Positive and negative zero error : Zero error can be positive or negative depending upon whether the zero of vernier scale lies to the right or to the left of the zero of the main scale.

- » Zero error is positive when the zero of the vernier scale lies to the right of the main scale when jaws A and B are in contact.

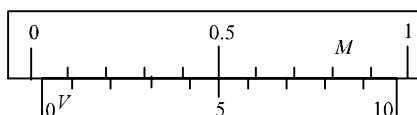

- » Zero error is negative when the zero of vernier scale lies to the left of zero of the main scale when jaws A and B are in contact.

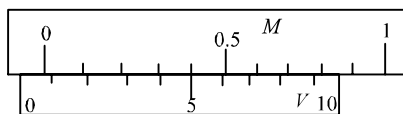

- » Zero error is nil when zero vernier scale coincides with zero of main scale when jaws A and B are in contact.

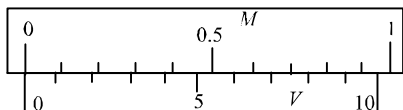

- To measure the diameter of a given ball we clamp the ball gently between the jaws of callipers avoiding excessive pressure. Note the main scale reading (x) before the zero of vernier scale. Look for the coinciding vernier scale division. Let it be y .

$$\therefore \text{Observed diameter, } D = x + y \times \text{V.C.}$$

$$\text{Corrected diameter } D' = D \pm \text{zero correction}$$

$$\text{Corrected diameter, } D' = D \mp (\text{zero error})$$

If zero error is positive, then it is subtracted. When it is negative, then added.

- The upper jaws of vernier callipers are used to measure the internal dimensions of a body such as diameter of a tube/beaker etc.
- The sliding strip of vernier callipers is used to measure the depth of a vessel.

2. SCREW GAUGE - Its use to determine thickness/diameter of thin sheet/wire

- A screw gauge is used to measure even smaller dimensions than those measure by vernier callipers. It is used to measure distances upto 0.01 mm or 0.001 cm.
- The principle of screw gauge is that linear motion of screw of screw gauge is directly proportional to the rotational motion. The labelled diagram of a screw gauge is shown below.

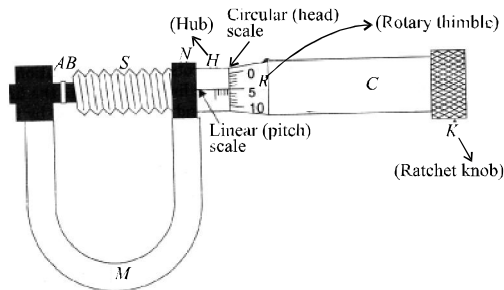

- The rotatory thimble (R) is subdivided into 100 equal divisions. It is called circular or head scale. The thimble passes through a frame known as hub (H) that carries a millimetre scale graduated on the reference line. This scale is called linear scale or pitch scale. The jaw can be adjusted by rotating the thimble using a small ratchet using a small ratchet knob (K).
- The least count of a screw gauge depends on (i) pitch, (ii) number of divisions on circular scale
- **Pitch of a screw gauge** : It is defined as the linear distance moved by the screw in one complete rotation of its head.

$$\text{Pitch} = \frac{\text{distance moved in } n \text{ rotations}}{n}$$

- The screw gauge used in laboratories have a pitch of 1 mm.
- **Least count of the screw gauge** : It is defined as the distance moved by the screw when circular scale is rotated through one division on it.

$$\therefore \text{Least count} = \frac{\text{Pitch}}{\text{No. of divisions on circular scale}}$$

The circular scale has usually 100 divisions on it.

$$\text{Least count} = \frac{1 \text{ mm}}{100} = 0.01 \text{ mm} = 0.001 \text{ cm}$$

So, the screw gauge has more accuracy in measurement than vernier callipers.

- **Reading of screw gauge** : If the edge of the cap lies ahead of N^{th} division of linear scale, then linear scale reading (L.S.R.) is N .
If n^{th} division of circular scale lies over a reference line, then circular reading (C.S.R.) is $n \times (\text{L.C.})$
(where L.C. is least count of screw gauge.)
Total reading (T.R.) = L.S.R. + C.S.R.
 $= N + n \times (\text{L.C.})$

- **Zero error and zero correction**
 - » Zero error in screw gauge arises when the zero of circular scale does not coincide with zero on the reference line of graduation, when the screw gauge is completely closed.
 - » Zero error is positive, when zero of circular scale lies below the line of graduation.
 - » Zero error is negative, when zero of circular scale lies above the line of graduation. In either case, we note circular scale reading on the line of graduation, and multiply it with least count of screw gauge.
 - » Zero correction has a magnitude equal to zero error, but its sign is opposite to that of zero error.
- To measure the diameter of a wire, close the screw gauge carefully holding the wire in

between till the ratchet gives a tick. Note the linear scale reading x and circular scale reading y .

Observed diameter, $D = x + y \times \text{L.C.}$

Corrected diameter, $D' = D \pm \text{zero correction.}$

- **Backlash error** in a screw gauge arises when we suddenly reverse the sense of rotation of circular scale. The backlash error develops on account of worn out threadings. Backlash error can be avoided by rotating the screw in the same sense.

3. SIMPLE PENDULUM - Dissipation of energy by plotting a graph between square of amplitude and time

- A simple pendulum consists of a heavy point mass m (called bob) hanging from perfectly inextensible, flexible and weightless string of length l and fixed at a pivot point P . When displaced to an initial angle and released, the pendulum will swing back and forth with periodic motion.

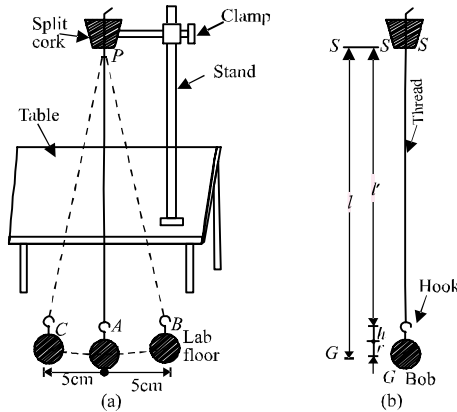

A is the mean position. B and C are the extreme positions. The length of the pendulum is the distance between the point of suspension of the pendulum and its centre of gravity, *i.e.*

Length of the simple pendulum = length of the thread + length of the hook of bob + radius of bob.

$$l = l' + h + r$$

- **Dissipation of energy by plotting a graph between square of amplitude and time.**

Principle : When a pendulum swings in air, it eventually stops. This happens as the air drag and the friction at the support, oppose the motion of the pendulum and dissipate its energy gradually.

For a simple harmonic oscillator the restoring or the spring force is represented by $F_s = -kx$ where x is the displacement from the equilibrium position. For damping, we can take an additional drag force opposite and proportional to its velocity.

$$F_d = -bv$$

Thus total force acting on the oscillator

$$F = -kx - bv.$$

Using Newton's second law,

$$m \frac{d^2x}{dt^2} = -kx - b \frac{dx}{dt} \quad \text{or} \quad m \frac{d^2x}{dt^2} + b \frac{dx}{dt} + kx = 0$$

The solution to this differential equation is

$$x = A_0 e^{-\frac{bt}{2m}} \cos(\omega' t + \phi) \text{ where } \omega' = \sqrt{\frac{k}{m} - \frac{b^2}{4m^2}}$$

We can regard the displacement as a sine function whose amplitude which is $A_0 e^{-\frac{bt}{2m}}$, gradually decreases with time.

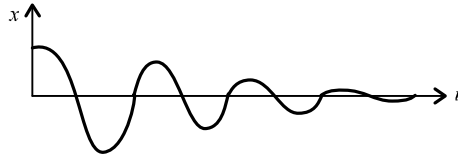

The energy of a undamped mechanical oscillator is constant, and is given by $E_0 = \frac{1}{2} k A_0^2$.

If the oscillator is damped, the mechanical energy is not constant but decreases with time.

$$\therefore E = \frac{1}{2} k \left(A_0 e^{-\frac{bt}{2m}} \right)^2$$

$$E = \frac{1}{2} k A_0^2 \left(e^{-\frac{bt}{m}} \right)$$

$$E = E_0 e^{-\lambda t} \text{ where } \lambda = \frac{b}{m} = \text{constant}$$

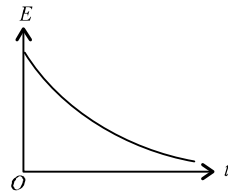

Alternatively, if we plot the amplitude A at any given time t ,

$$\text{with } t, A^2 = A_0^2 e^{-\frac{bt}{m}}$$

$$\text{or } A^2 = A_0^2 e^{-\lambda t}$$

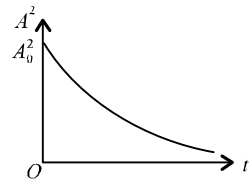

As energy is proportional to A^2 for an oscillator, the graph shows the dissipation of energy with time.

4. METRE SCALE - Mass of a given object by principle of moments

- Like physical balance, a metre scale can be used as a beam balance making use of principle of moments.
- *Principle* : A metre scale is supported at its centre of gravity on a wedge as shown.

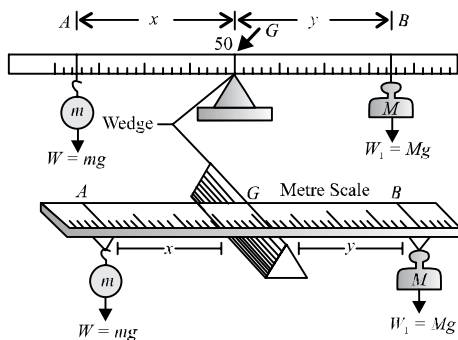

- An unknown mass m of weight mg is suspended from the left arm at a distance x and a known standard mass M of weight Mg is suspended from the right arm at a distance y .

The distances are measured from the wedge. For equilibrium, the moments of forces about the wedge is equal.

$$mg \times x = Mg \times y$$

$$m = M \left(\frac{y}{x} \right)$$

5. Young's modulus of elasticity of the material of a metallic wire

- **Elasticity** : It is the property of the body by virtue of which the body regains its original configuration when the deforming force is removed.
- Young's modulus (Y) is a measure of the stiffness of a given material. It is known as modulus of elasticity. It is defined as the ratio of normal stress to the longitudinal strain.

$$Y = \frac{MgL}{\pi r^2 l}$$

where M = mass of wire, L = length of wire, l = increase in length, r = radius of wire

- The S.I. unit of Y is N m^{-2} and C.G.S. unit is dyne cm^{-2} .
- Young's modulus Y of the given material of the wire is determined by using Searle's apparatus. The labelled diagram of Searle's apparatus is shown in the figure below.

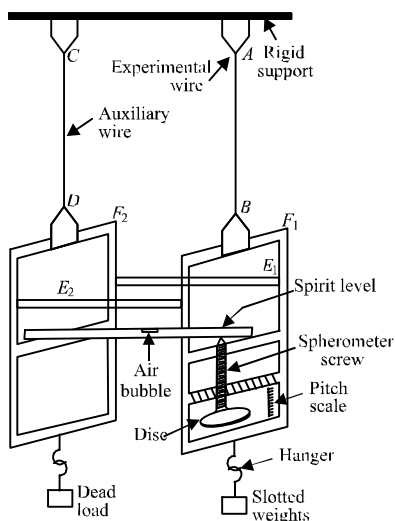

- Young's modulus of a body depends upon the nature of material of wire and is independent of dimensions of the wire.
- Young's modulus of elasticity is for solid body only. For liquid and gases, it is zero.
- Greater is the value of Y for a material, larger is its elasticity. As values of Y for copper and steel, are $1.1 \times 10^{11} \text{ N/m}^2$ and $2.0 \times 10^{11} \text{ N/m}^2$, so steel is more elastic than copper.

6. Surface tension of water by capillary rise and effect of detergents

- Surface tension is that characteristic property of a liquid by virtue of which, its free surface possess a tendency to contract so as to acquire a minimum possible surface area.
- **Rise of liquid in capillary tube (Ascent formula)**

Let a capillary tube of radius r be dipped in a liquid which makes concave meniscus in the tube.

Let R = radius of curvature of liquid meniscus, P = atmospheric pressure, S = surface tension of the liquid.

The pressure at point A , just above the liquid meniscus in the capillary tube is atmospheric pressure = P .

The pressure at point B , just below the liquid meniscus = $P - \frac{2S}{R}$.

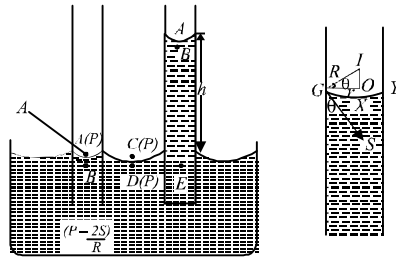

Pressures at points C and D just above and below the plane surface of liquid in the vessel is also P (atmospheric pressure). The points B and D are in the same horizontal plane in liquid but the pressure at these points is different. Hence there will be no equilibrium.

In order to maintain an equilibrium, the liquid level rises in the capillary tube up to a height h so that the pressures at points D and E which are in the same level in liquid may become equal.

\therefore Pressure at E = pressure at B + pressure due to height (h) of the liquid column
 $= \left(P - \frac{2S}{R} \right) + h\rho g$.

As there is an equilibrium,

\therefore pressure at E = pressure at D

$$\text{i.e., } P - \frac{2S}{R} + h\rho g = P \quad \text{or} \quad h = \frac{2S}{R\rho g} \quad \dots (i)$$

To find R (radius of curvature of liquid) from figure.

$$GI = R; \quad GO = r, \quad \angle IGO = \theta$$

$$\text{In } \triangle IGO, \quad \cos \theta = \frac{GO}{GI} = \frac{r}{R} \quad \text{or} \quad R = \frac{r}{\cos \theta} \quad \dots (ii)$$

$$\text{Put the value of } R \text{ from equation (ii) in equation (i), we get } h = \frac{2S \cos \theta}{r\rho g}$$

It gives the height of the column lifted and also known as ascent formula.

$$\text{From ascent formula; } S = \frac{hr\rho g}{2 \cos \theta}$$

- **Effect of detergents** : When a detergents added to water reduces the surface tension of water. For a given capillary tube, the rise of water in it varies directly with the surface tension. So, on adding a detergent to water its surface tension decreases. More is the decrease in surface tension, lesser would be rise of water in capillary tube.
7. **Coefficient of viscosity of a given viscous liquid by measuring terminal velocity of a given spherical velocity**
- **Viscosity** is the property of a fluid (liquid or gas) by virtue of which an internal frictional force comes into play when the fluid is in motion and opposes the relative motion of its different layers. It also called *fluid friction*.

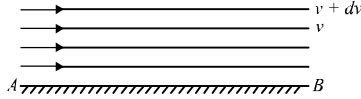

- When a liquid flows over a flat surface, liquid layer in contact with fixed surface AB does not move. Upper layers move forward with increasing velocity. Due to relative motion, a backward dragging force F acts tangentially to every layer which is given by

$$F = -\eta A \frac{dv}{dx}$$

η is constant of proportionality called *coefficient of viscosity*.

Definition : If $A = 1$, $dv/dx = 1$, then $F = \eta$.

Hence, coefficient of viscosity may be defined as the tangential force required to maintain a unit velocity gradient between two layers of unit area.

- The S.I. unit of coefficient of viscosity is poiseuille (PI).
- Terminal velocity** : The maximum velocity acquired by the body, falling freely in a viscous medium is called terminal velocity.

Considering a small sphere of radius r of density ρ falling freely in a viscous medium of density (σ). The forces acting on it are :

The weight of the sphere acting downward = $\frac{4}{3}\pi r^3 \rho g$

The upward thrust = weight of the liquid displaced by sphere = $\frac{4}{3}\pi r^3 \sigma g$.

The effective downward force

$$= \frac{4}{3}\pi r^3 \rho g - \frac{4}{3}\pi r^3 \sigma g = \frac{4}{3}\pi r^3 (\rho - \sigma)g$$

Upward force of viscosity : $F = 6\pi\eta r v$.

When the downward force is balanced by the upward force of viscosity, the body falls down with constant velocity called terminal velocity.

Hence, $6\pi\eta r v = \frac{4}{3}\pi r^3 (\rho - \sigma)g$

$$\eta = \frac{2}{9} \frac{r^2}{v} (\rho - \sigma)g.$$

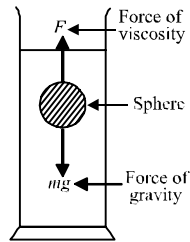

8. Plotting a cooling curve for the relationship between the temperature of a hot body and time

- A hot body can be subjected to natural cooling or a forced cooling by using conduction, convection or radiation.
- When loss of heat is by radiation only and surroundings are maintained at a constant low temperature, we can use Newton's law of cooling.
- According to Newton's law of cooling, when difference in temperature of a body and its surroundings is small, then the rate of loss of heat of the body is directly proportional to difference in temperatures of the body and the surroundings.

$$i.e., -\frac{dQ}{dt} \propto (\theta - \theta_0)$$

$$-\frac{dQ}{dt} = K(\theta - \theta_0) \quad \dots (i)$$

where θ = temperature of the body

θ_0 = temperature of surroundings

K = constant of proportionality

As $Q = sm\theta$, where m is mass and s is specific heat of the body.

$$\therefore -\frac{d}{dt}(sm\theta) = K(\theta - \theta_0)$$

$$-\frac{d\theta}{dt} = \frac{K}{sm}(\theta - \theta_0) \quad \dots \text{(ii)}$$

The variation of temperature of body with time is parabolic as shown in the figure.

Equation (ii) can be rewritten as

$$\frac{d\theta}{\theta - \theta_0} = -kdt \quad \dots \text{(iii)}$$

where $k = \frac{K}{sm}$ = constant

Integrating both sides of equation (iii),

$$\int_{\theta_1}^{\theta_2} \frac{d\theta}{\theta - \theta_0} = -k \int_0^t dt$$

$$[\log(\theta - \theta_0)]_{\theta_1}^{\theta_2} = -k(t - 0)$$

$$\log \frac{\theta_2 - \theta_0}{\theta_1 - \theta_0} = -kt$$

Here θ_1 is initial temperature at zero time and θ_2 final temperature at time t .

The graph between $\log(\theta - \theta_0)$ and time is a straight line as shown aside.

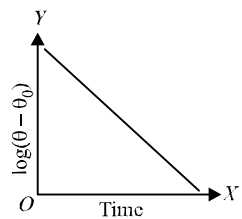
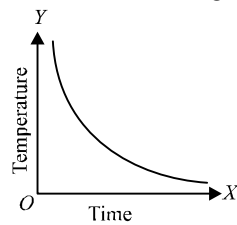

9. Speed of sound in air at room temperature using a resonance tube

- A resonance tube is a tube open on one-side and closed at the other by water surface. The tube is made to resonate with a tuning fork for two different positions.

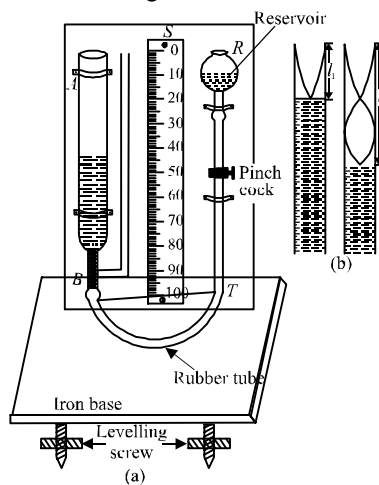

- *Principle* : The resonance tube works on the phenomena of resonance of air column.
Let l_1 and l_2 be the lengths of the air columns for the first and the second resonances respectively with a tuning fork of frequency ν . Then, $\lambda = 2(l_2 - l_1)$
As $\nu = \nu\lambda$, $\therefore \nu = \nu 2(l_2 - l_1)$
Therefore, speed of sound at room temperature is given by $\nu = 2\nu(l_2 - l_1)$.

10. Specific heat capacity of a given (i) solid and (ii) liquid by method of mixtures

- *Specific heat capacity* of a substance is defined as the amount of heat required to raise the temperature of unit mass of the substance through unit degree.
- When two substances at different temperatures are mixed, then heat is exchanged between them. The substance at higher temperature loses heat and the one at lower temperature gains heat till they come to an equilibrium temperature. This is the law of mixtures.
- *Principle of mixtures* : The amount of heat lost by the hotter body equals the amount of heat gained by the colder body provided (i) no heat is lost to the surroundings and (ii) the substances do not react chemically to produce or absorb heat.

For body of mass m , having a specific heat s , the amount of heat gained or lost ΔQ is given by

$$\Delta Q = ms\Delta\theta$$

where $\Delta\theta$ is the rise or fall in the temperature of the body.

• Method of mixtures

Solid : The solid is weighed to find its mass m , heated in boiling water at temperature θ_3 for 10 minutes as shown in the figure (i), then quickly transferred to a calorimeter of mass m_c containing a mass of water m_w at temperature

θ_1 as shown in figure (ii).

The water is stirred and the highest reading θ_2 on the thermometer noted.

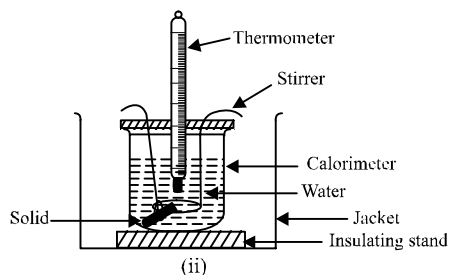
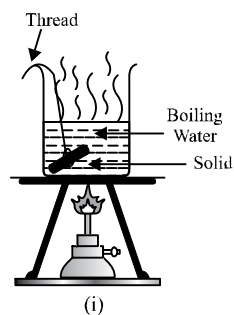

Assuming no heat loss from the calorimeter when the hot solid is dropped into it. We have

heat given out by solid cooling from θ_3 to θ_2

= heat received by water warming from θ_1 to θ_2

+ heat received by calorimeter warming from θ_1 to θ_2

If s is the specific heat capacity of the solid, s_w that of water and s_c that of the calorimeter, then

$$\begin{aligned} ms(\theta_3 - \theta_2) &= m_w s_w (\theta_2 - \theta_1) + m_c s_c (\theta_2 - \theta_1) \\ &= [m_w s_w + m_c s_c] (\theta_2 - \theta_1) \end{aligned}$$

$$\therefore s = \frac{[m_w s_w + m_c s_c](\theta_2 - \theta_1)}{m(\theta_3 - \theta_2)}$$

Liquid : In this case a hot solid of known specific heat capacity is dropped into the liquid whose specific heat capacity is required; the procedure and calculations are the same as that of solid.

11. Resistivity of the material of a given wire using Metre Bridge

- Metre bridge is the practical form of Wheatstone bridge. In a metre bridge, P and Q are the ratio arms of fixed resistance, R is an adjustable or variable resistance of known value. X is the unknown resistance and balance point is obtained at B on the metre bridge wire. Since the bridge uses 1 metre long wire, it is called metre bridge. Since a jockey is slid over the wire, it is called slide wire bridge.

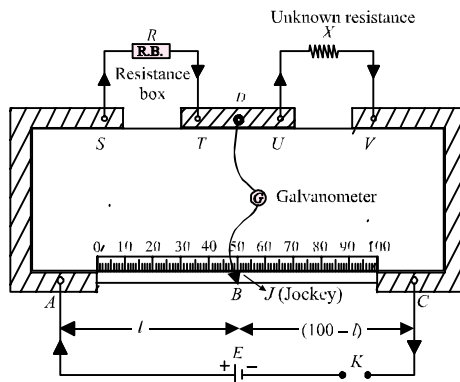

Let $AB = l$ cm and $BC = (100 - l)$ cm.

$$\frac{P}{Q} = \frac{\text{Resistance of } AB}{\text{Resistance of } BC} \therefore \frac{P}{Q} = \frac{l}{100-l}$$

According to Wheatstone's bridge

$$\frac{P}{Q} = \frac{R}{X} \text{ or } X = \frac{Q}{P} R = \frac{(100-l)R}{l}$$

For specific resistance, $X = \rho \frac{l}{A}$ or $\rho = \frac{XA}{L} = \frac{X\pi D^2}{4L}$

where L is the length and D is the diameter of the given wire.

12. Resistance of a given wire using Ohm's law

- To find the resistance of given wire using Ohm's law, we require the following apparatus. A resistance wire, a voltmeter and an ammeter of appropriate range, battery, a rheostat, a one way key and connecting wires. The circuit diagram is shown below.

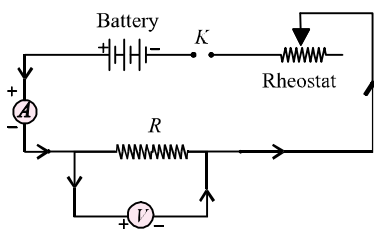

- **Principle** : It states that the physical conditions (temperature, mechanical strain etc) remaining unchanged, the current flowing through a conductor is always directly proportional to the potential difference across its two ends.

Mathematically, $V \propto I$ or $V = RI$

where R is a constant of proportionality called resistance

of the conductor. The unit of resistance is volt per ampere or ohm (Ω).

Its value depends upon the nature of the conductor, its dimensions and the physical conditions.

- While making connections, ensure that positive marked terminals of ammeter and voltmeter are joined towards the positive terminal of the battery.

The sample graph of V vs I is shown below.

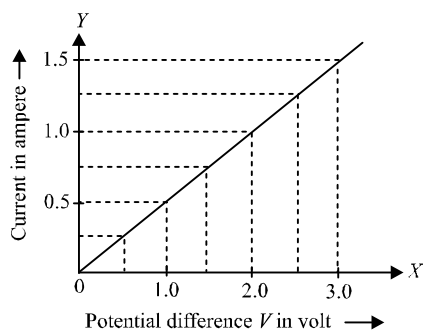

13. POTENTIOMETER

(i) Comparison of emf of two primary cells

(ii) Internal resistance of a cell

- It is an electrical instrument by which we compare e.m.fs of two cells and can determine the internal resistance of a cell.
- **Principle of potentiometer** : The working of potentiometer is based on the fact that voltage drop (V) across any section of the potentiometer wire is directly proportional to the length (l) of that section provided the wire is of uniform area of cross-section (A) and a constant current (I) is flowing through it. *i.e.* $V \propto l$ or $V = kl$ where k is proportionality constant, it is called the potential gradient along the potentiometer wire.
- **Comparison of e.m.f.'s of two cells**
For comparison of emf's of two cells using potentiometer, the circuit arrangement used is shown below.

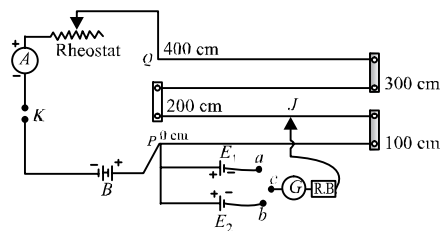

With the help of a voltmeter we can measure only the terminal potential difference of a cell, but using a potentiometer we can determine the value of e.m.f. (electromotive force) of a given cell. The e.m.f. of the auxiliary battery B is constant and more than that of given cell. Insert the key K . A constant current I flows through the potentiometer wire PQ and a potential gradient $k = I\sigma$ is set up, where σ is the resistance per unit length of the potentiometer wire.

The positive terminals of the cells, E_1 and E_2 are connected to the zero end terminal P of the potentiometer, whereas the negative terminals are connected through a two-way key to a galvanometer, a resistance box and a jockey. When the cell E_1 is in circuit, on sliding the jockey gently along the potentiometer wire PQ a point J , say at a distance l_1 from the zero end, is obtained where the galvanometer shows no deflection. In such a case the $-ve$ terminal of the cell E_1 and the point J on the potentiometer wire are at the same potential. The zero end of the potentiometer wire and the $+ve$ terminal of cell E_1 are also at the same potential. Hence, fall of potential along the length l_1 of the potentiometer wire is equal to the e.m.f. of the cell E_1 as no current is being drawn from the cell. As the fall of potential along a wire of a uniform area of cross-section is proportional to its length.

$$\therefore E_1 \propto l_1 \quad \text{or} \quad E_1 = kl_1 \quad \dots(i)$$

where, k is the potential gradient along the wire PQ .

Similarly, a point at a distance l_2 from the zero end of the wire PQ can be obtained with the cell E_2 , where the galvanometer shows no deflection, so that again

$$E_2 \propto l_2 \quad \text{or} \quad E_2 = kl_2 \quad \dots(ii)$$

Dividing equation (i) by (ii), we get

$$\frac{E_1}{E_2} = \frac{kl_1}{kl_2} = \frac{l_1}{l_2} \quad \therefore \frac{E_1}{E_2} = \frac{l_1}{l_2}$$

● **Internal resistance of a cell**

Circuit in figure shows a cell of e.m.f. E and internal resistance r , connected to an external resistance R . The circuit has total resistance $(R + r)$ and current I in circuit is given by

$$I = \frac{E}{(R + r)} \quad \text{or} \quad E = I(R + r)$$

The potential difference of cell V

$$= \text{P.D. between } A \text{ and } D = E - Ir$$

$$= \text{P.D. between } B \text{ and } C = IR$$

$$\text{Hence, } V = E - Ir = IR$$

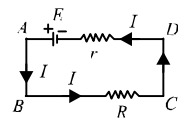

(V is less than E , by the amount equal to fall of potential inside the cell due to its internal resistance)

$$\text{From above } Ir = E - V \quad \text{and} \quad IR = V$$

$$\text{Dividing, } \frac{r}{R} = \frac{E - V}{V} \quad \text{or} \quad r = R \left(\frac{E - V}{V} \right) \quad \dots(i)$$

This equation relates E , V and r in a circuit of external resistance R .

● **Determination of internal resistance using a potentiometer**

For determination of internal resistance of a cell by a potentiometer, the circuit arrangement used is shown in figure below.

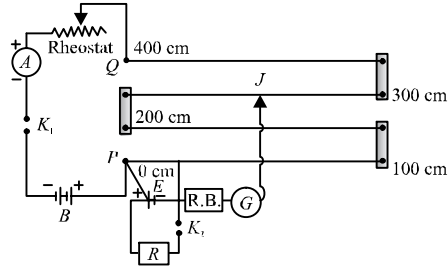

E is the cell whose internal resistance is to be measured. By adjusting the rheostat and closing key K_1 , if l_1 is the length of the potentiometer wire to the point where a balance point is obtained in an open circuit *i.e.*, K_2 is open, then $E = kl_1$ where, k is the potential gradient along the potentiometer wire.

If the balance point is obtained at l_2 when the cell sends a current through shunted resistance R when K_2 is also closed, then potential difference between the terminals of the cell

$$V = kl_2$$

Putting the values of E and V in eqn. (i),

$$r = R \left(\frac{l_1 - l_2}{l_2} \right)$$

14. Resistance and figure of merit of a galvanometer by half deflection method

- A galvanometer is a device used for detecting feeble electric currents in a circuit. It has a coil suspended between concave poles faces of a strong laminated horse shoe magnet. When an electric current passes through the coil it deflects and the deflection is noted by attached a pointer to the coil. The deflection is directly proportional to the current passed.

The circuit diagram for finding the resistance of a galvanometer by half deflection method is shown below.

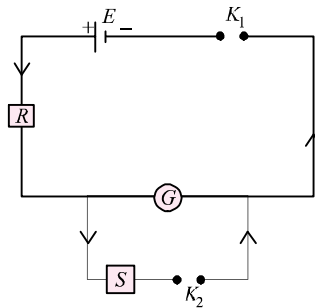

The resistance of galvanometer as found by half deflection method is $G = \frac{RS}{R-S}$

where R is the resistance connected in series with the galvanometer and S is the shunt resistance.

- Figure of merit of a galvanometer** : It is defined as the current required to produce deflection of one division in the scale of galvanometer. Its symbol is k . When current I produces a deflection θ in the galvanometer, then figure of merit is given by

$$k = \frac{I}{\theta} = \frac{E}{(R + G)\theta}$$

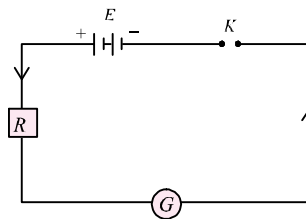

If n is the number of divisions in the galvanometer scale, then current required to produce full scale deflection is given by $I_g = nk$

15. Focal length of (i) convex mirror, (ii) concave mirror, (iii) convex lens

- To find the value of v for different values of u in case of a concave mirror and to find its focal length by plotting graph between u and v .

To perform the experiment, we require an optical bench with three uprights (zero end upright fixed, two outer uprights with lateral movement), concave mirror, a mirror holder, two optical needles (one thin, one thick), a knitting needle and a half metre scale.

The following ray-diagram explains the essence of this experiment.

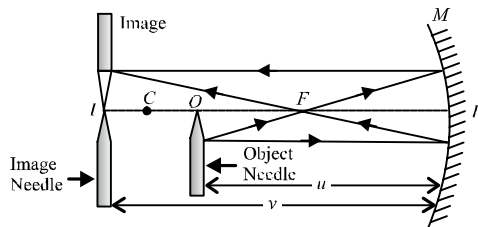

Formula used

From mirror formula, $\frac{1}{f} = \frac{1}{v} + \frac{1}{u}$

We have, $f = \frac{uv}{u + v}$

where, f = focal length of concave mirror

u = distance of object needle from pole of the mirror

v = distance of image needle from pole of the mirror.

Note: According to sign-convention u and v have negative values. Hence f comes negative.

To determine the rough focal length of the mirror, the image of a far off tree or a building is taken on a wall. The distance between mirror and wall gives us a rough idea of the focal length of the mirror.

Then set the object needle at 1.5 times the f distance. An inverted and enlarged image of the needle will be seen. The other needle (image needle) is used to locate the exact position of the image. We displace the image needle till the tip of the image coincide with it. Read off u and v . Change u and read corresponding v for various observations.

Then plot a graph between u and v .

- **Calculations of focal length using graph**

u-v Graph: Select a suitable but the same scale to represent u along X' -axis and v along Y' -axis. According to sign conventions, in this case u and v both are negative. Plot the various points for different sets of values of u and v from the observation table. The graph comes out to be a rectangular hyperbola as shown in figure below.

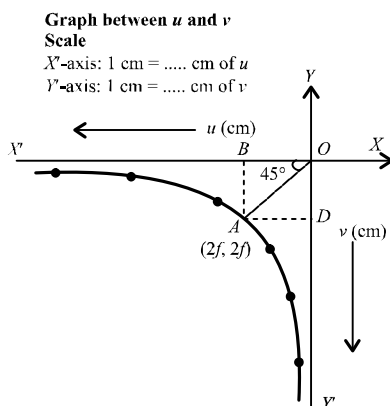

Draw a line OA making an angle of 45° with either axis (*i.e.*, bisecting $\angle Y'OX'$) and meeting the curve at point A . Draw AB and AD perpendicular on X' and Y' -axis respectively. The values of u and v will be same for point A . So the coordinates of point A must be $(2f, 2f)$ because for a concave mirror u and v are equal only when the object is placed at the centre of curvature.

Hence, $u = v = R = 2f$

Explanation

From mirror formula applied to point A

$$\frac{1}{f} = \frac{1}{u} + \frac{1}{v}$$

$$\text{As } u = v, \quad \frac{1}{f} = \frac{2}{u} \quad \text{or} \quad \frac{2}{v} \quad \text{and} \quad f = \frac{u}{2} \quad \text{or} \quad \frac{v}{2}$$

Hence, half the values of either coordinate of A (*i.e.*, distance OD or OB) gives the focal length of the concave mirror.

$$f = \frac{OD}{2} = \frac{OB}{2} = \dots \text{ cm}$$

- **To find the focal length of a convex mirror using a convex lens.**

To perform the experiment, we require an optical bench with four uprights (two fixed uprights in middle, two outer uprights with lateral movement), convex lens (20 cm focal length), convex mirror, a lens holder, a mirror holder, two optical needles, (one thin, one thick) a knitting needle, and a half metre scale.

The following ray-diagram explains the essence of this experiment.

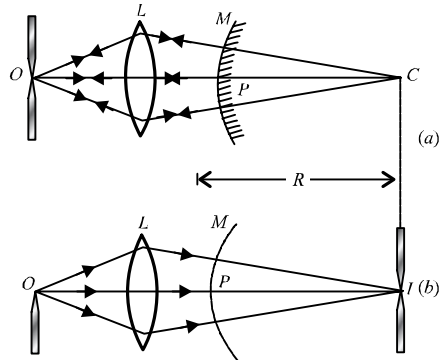

Focal length of convex mirror

As a convex mirror always forms a virtual image, its focal length can not be found directly as for a concave mirror. For this purpose, indirect method is used, as described below.

An auxiliary convex lens L is introduced between the convex mirror M and object needle O as shown in figure (a). Keeping the object needle at distance about 1.5 times rough focal length of convex lens, the position of convex mirror behind convex lens is so adjusted that a real and inverted image of object needle O , is formed at O itself. Under such condition, the light rays are incident normally over the convex mirror to retrace their path. In the absence of convex mirror, these rays would have met at centre of curvature C of the convex mirror. The distance PC gives the radius of curvature R of the mirror.

To locate the position of C , convex mirror is removed (without disturbing the object needle O and convex lens L). An image needle I is put behind the convex lens and moved to a position at which there is no parallax between tip of inverted image of O needle and tip of I needle. Position of image needle I gives position of centre of curvature C of mirror M . (See figure above).

Then, $PC = PI = R$ and $f = \frac{R}{2} = \frac{PI}{2}$

- **To find the focal length of a convex lens by plotting graph between u and v .**

To perform the experiment, we require an optical bench with three uprights (central upright fixed, two outer uprights with lateral movement), a convex lens with lens holder, two optical needles, (one thin, one thick) a knitting needle and a half metre scale.

The following ray diagram explains the essence of this experiment.

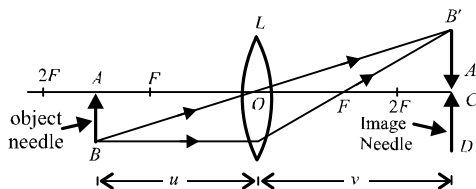

Formula used

The relation between u , v and f for a convex lens is

$$\frac{1}{f} = \frac{1}{v} - \frac{1}{u}$$

where, f = focal length of convex lens

u = distance of object needle from optical centre of the lens

v = distance of image needle from optical centre of the lens.

Note: According to sign-convention, u has negative value and v has positive value. Hence, f comes positive.

Calculation of focal length by using graph.

u-v Graph : Select a suitable but the same scale to represent u along X' -axis and v along Y -axis. According to sign conventions, in this case, u is negative and v is positive. Plot the various points for different sets of values of u and v from observation table. The graph comes out to be a rectangular hyperbola as shown in figure below.

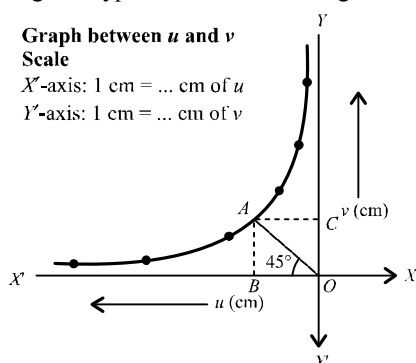

Draw a line OA making an angle of 45° with either axis (*i.e.*, bisecting $\angle YOX'$) and meeting the curve at point A . Draw AB and AC perpendicular on X' and Y -axes, respectively.

The values of u and v will be same for point A . So the coordinates of point A must be $(2f, 2f)$, because for a convex lens, when $u = 2f$, $v = 2f$.

Hence, $AB = AC = 2f$ or $OC = OB = 2f$

$\therefore f = OB/2$ and also $f = OC/2$

\therefore Mean value of $f = \dots$ cm

16. Using parallax method, plot of angle of deviation vs angle of incidence for a triangular prism.

- The apparatus required is a drawing board, white sheet of paper, prism, drawing pins, pencil, half metre scale, office pins, graph paper and a protractor.

The white paper is pinned to the drawing board and the prism is fixed at a place. The outline of the prism is marked on the paper. Then an incident ray say (at 30°) is drawn on one of the faces of the prism and two pins are inserted at P_1 and P_2 on the ray as shown below.

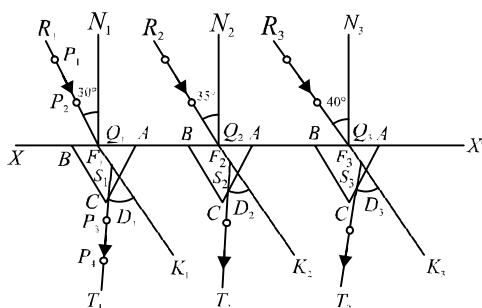

When viewed from the other face the pins are along a particular line. We place pins P_3 and P_4 in line with the images of P_1 and P_2 as seen in the prism. Thereafter line P_3P_4 is drawn which represents the emergent ray. Lift the prism and make the dotted lines and discover the angle of deviation D_1 here. This angle can be measured by a protractor. Several such observations for angle of incidence ranging from 30° to 60° can be made and the corresponding angle of deviation can be measured. Plot a graph between D vs i . A sample graph is drawn below.

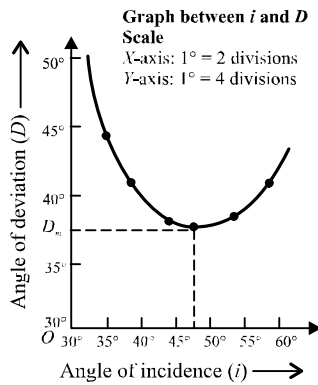

From the graph the minimum value of deviation can be obtained. Angle A can be measured by the protractor from the outline of the prism. To get refractive index of the material of the prism, prism formula is used as follows.

$$\mu = \frac{\sin\left(\frac{A + D_m}{2}\right)}{\sin\left(\frac{A}{2}\right)}$$

17. Refractive index of a glass slab using a travelling microscope

- **Real and apparent thickness of glass slab**

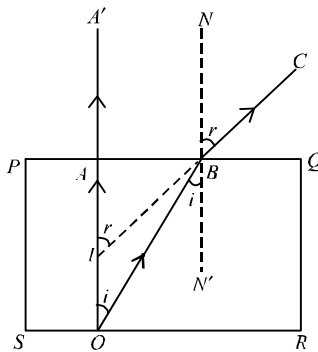

O is the point object at the bottom of glass slab $PQRS$. A ray of light is incident normally along OA passes straight along OAA' . Another ray of light from O at the bottom of slab incident at $\angle i$ on PQ , along OB deviates away from normal. It is refracted at $\angle r$ along BC . On producing back, BC meets OA at I .

Therefore, I is virtual image of O .

\therefore The apparent thickness = AI

Real thickness = OA

$\angle AOB = \angle OBN' = i$ (alternate interior \angle s),

$\angle AIB = \angle NBC = r$ (corresponding \angle s)

In $\triangle OAB$, $\sin i = \frac{AB}{OB}$. In $\triangle IAB$, $\sin r = \frac{AB}{IB}$.

As light is travelling from denser to rarer medium.

$${}^a\mu_g = \frac{\sin r}{\sin i} = \frac{AB}{IB} \times \frac{OB}{AB} = \frac{OB}{IB}$$

When angles are small, B is close to A .

$$\therefore {}^a\mu_g = \frac{OA}{IA} = \frac{\text{Real thickness}}{\text{Apparent thickness}} \quad \text{or} \quad \mu = \frac{\text{Real thickness of slab}}{\text{Apparent thickness of slab}}$$

To determine refractive index of a glass slab, using a travelling microscope, the required apparatus is three glass slabs of different thickness but same material, a travelling microscope, lycopodium powder.

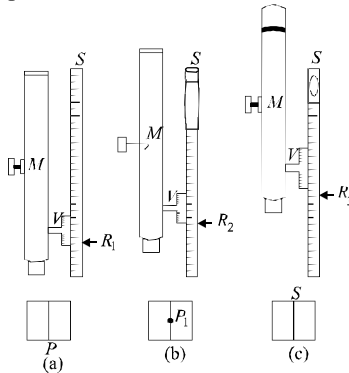

Reading on vertical scale when microscope is focussed on cross mark without slab = R_1 cm, cross mark with slab = R_2 cm and lycopodium powder = R_3 cm.

Real thickness = $(R_3 - R_1)$ cm

Apparent thickness = $(R_3 - R_2)$ cm

$$\text{Refractive index } \mu = \frac{R_3 - R_1}{R_3 - R_2}$$

18. Characteristic curves of p - n junction diode in forward and reverse bias

- **Forward bias characteristics :** To draw characteristic curves of p - n junction diode in forward bias following circuit diagram is required.

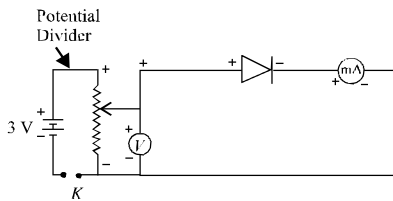

- Forward bias on junction:** It produces forward current. With increase in bias voltage, the forward current increases slowly in the beginning and then rapidly. At about 2.4 V, the current increases suddenly. The bias is at once made zero to avoid damage to the diode.

Calculations : Plot a graph between forward bias voltage V_F and forward current I_F taking V_F along X-axis and I_F along Y-axis.

A sample graph is shown below.

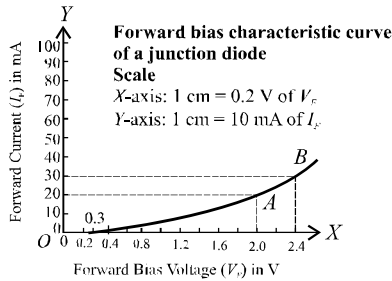

This graph is called forwards bias characteristic curve of a junction diode.

- Reverse bias characteristics :** For this characteristics the following circuit diagram required.

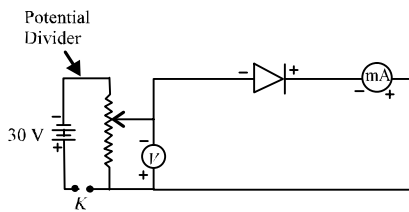

- Reverse bias on junction:** In the beginning no appreciable reverse current flows. At about 5 V a feeble current starts flowing. With increase in bias voltage, the current slowly increases. At about 25 V the reverse current increase suddenly. Again the bias is made zero to avoid damage.

Calculations

Plot a graph between reverse bias voltage V_R and reverse current I_R taking V_R along X-axis and I_R along Y-axis. A sample graph is shown below.

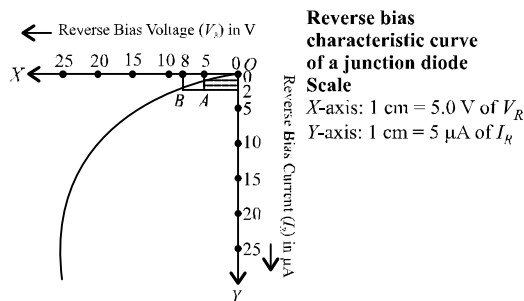

This graph is called reverse bias characteristic curve of a junction diode.

In the first graph, for change from point A to B

$$\Delta V_F = 2.4 - 2.0 = 0.4 \text{ V}, \Delta I_F = 30 - 20 = 10 \text{ mA}$$

Hence junction resistance for forward bias,

$$r = \frac{\Delta V_F}{\Delta I_F} = \frac{0.4 \text{ V}}{10 \text{ mA}} = 40 \text{ ohm}$$

In the second graph, for change from point *A* to *B*

$$\Delta V_R = 8.0 - 5.0 = 3 \text{ V}, \Delta I_R = 2 - 1 = 1 \mu\text{A}$$

Hence junction resistance for reverse bias,

$$r = \frac{\Delta V_R}{\Delta I_R} = \frac{3 \text{ V}}{1 \mu\text{A}} = 3 \times 10^6 \text{ ohm.}$$

19. Characteristic curves of a Zener diode and finding reverse break down voltage

- **Zener diode** : It is a specially designed junction diode which can operate continuously without being damaged in the region of reverse breakdown voltage. It is used as a voltage regulator.
- **Zener breakdown** : When the junction diode is reverse biased, free charge carriers are attracted away, (in reverse direction) from junction. As the carriers do not cross the junction, no current flows in external circuit.

As the bias voltage is increased, covalent bonds between atoms break, setting more electrons and holes free in each section. The free holes in *n*-type section and free electrons in *p*-type section, are called minority carriers.

The reverse bias makes these minority carriers move towards junction and cross it. Thus a current flows through junction and in opposite direction. The current is very small.

At a certain reverse bias voltage a breakdown takes place and the current rises suddenly. The breakdown is called Zener breakdown and the voltage is called Zener voltage (V_Z) as shown in figure. There is a large change in diode current for a small change in diode voltage.

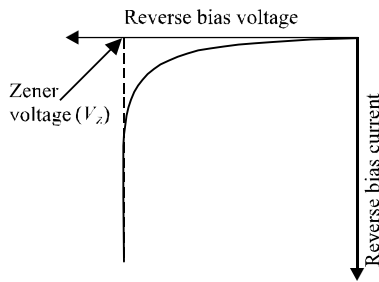

• Characteristics of Zener diode

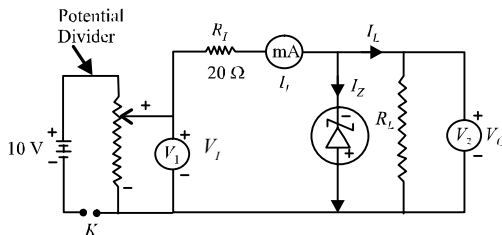

Circuit parameters : In the circuit as shown in the figure,

- V_i = Input (reverse bias) voltage
- V_o = Output voltage (R_L/I_L)
- R_i = Input resistance
- R_L = Load resistance
- I_i = Input current (reverse current)
- I_Z = Zener diode current
- I_L = Load current

Relations

$$I_L = I_i - I_Z \quad \dots(i)$$

$$V_o = V_i - R_i I_i \quad \dots(ii)$$

$$V_o = R_L I_L \quad \dots(iii)$$

Initially as V_i is increased, I_i increases a little, then V_o increases.

At breakdown, increase of V_i increases I_i by large amount, so that $V_o = V_i - R_i I_i$ becomes constant.

This constant value of V_o which is the reverse breakdown voltage is called *Zener voltage*.

Calculations

Note : A graph between V_i and I_i will give reverse bias characteristic of the Zener diode. Plot a graph between input voltage V_i and output voltage V_o , taking V_i along X-axis and V_o along Y-axis. The graph comes as shown below. Since V_o becomes constant at 6 volt the reverse breakdown voltage (Zener voltage) of Zener diode is 6 volt.

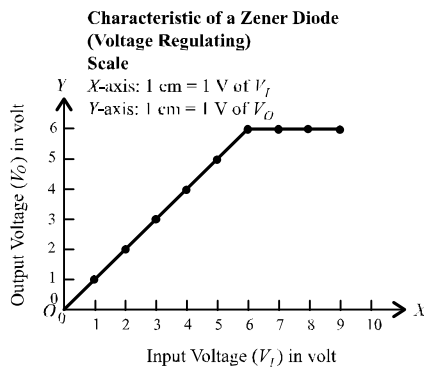

The reverse breakdown voltage of a given Zener diode is 6 volt.

20. Characteristic curves of a transistor and finding current gain and voltage gain

Graph drawn between bias voltage and current in the circuit, are called characteristics of the transistor. They show the way of behaviour of the transistor.

There are two types of characteristics

- (i) Input characteristics
- (ii) Output characteristics

- **Input characteristics :** In common base circuit (circuit in which base is common between input section and output section) these are obtained by plotting graphs between emitter voltage (V_E) and emitter current (I_E) for different constant collector voltage (V_C). In common emitter circuit (circuit in which emitter is common between input and output section) the input characteristics are obtained by plotting graphs between base voltage

- (V_B) and base current (I_B) for different constant collector voltage (V_C).
- **Output characteristics :** In common base circuit, these are obtained by plotting graphs between collector voltage (V_C) and the collector current (I_C) for different constant emitter current (I_E).
In common emitter circuit, these are obtained by plotting graphs between collector voltage (V_C) and the collector current (I_C) for different constant base current (I_B).
 - **Current gain and voltage gain**

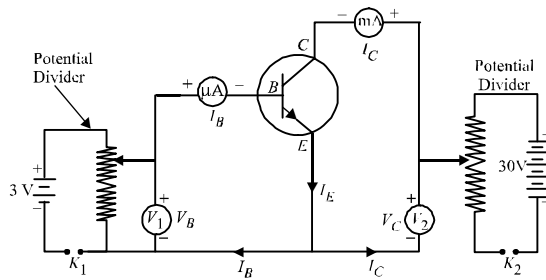

In common emitter circuit of a transistor, emitter base make input section and emitter collector make output section. As usual, base junction (input junction) is forward biased and collector junction (output junction) is reverse biased.

Resistance offered by base junction, is called input resistance (R_I). It has a very small resistance due to forward biasing.

Resistance offered by collector junction, is called output resistance (R_O). It has a high value due to reverse biasing.

Due to high output resistance (resistance in output section), a high resistance can be used as load resistance (R_L). Generally $R_L = R_O$.

The ratio $\frac{R_L}{R_I} = \frac{R_O}{R_I}$ measured resistance gain of the common emitter transistor. It is of the order of one thousand.

Also emitter current (I_E) divides itself into base current (I_B) and collector current (I_C). In $n-p-n$ transistor, I_C is about 98% of I_E , base current I_B remains only 2% of I_E . A little change in I_B causes a large change in I_C . The ratio of change in collector current to the corresponding change in base current, measures current gain in common emitter transistor.

It is represented by symbol β . i.e., $\beta = \frac{\Delta I_C}{\Delta I_B}$.

Formula used

$$\text{Input resistance, } R_I = \frac{\Delta V_B}{\Delta I_B}$$

$$\text{Output resistance, } R_O = \frac{\Delta V_C}{\Delta I_C}$$

$$\text{Resistance gain, } = \frac{R_O}{R_I}$$

$$\text{Current gain, } \beta = \frac{\Delta I_C}{\Delta I_B}$$

$$\text{Voltage gain} = \text{Current gain} \times \text{Resistance gain}$$

i.e., $A_V = \beta \cdot \frac{R_O}{R_I}$

Calculations

Calculation for input resistance (R_I) : Plot a graph between base voltage V_B and base current I_B for zero collector voltage V_C , taking V_B along the X-axis and I_B along the Y-axis. Plot graphs for different values of V_C . The graphs comes as shown in figure below.

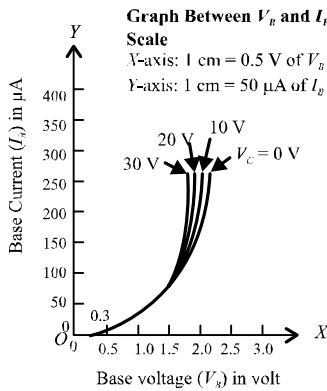

These graphs are called input characteristics of a common emitter transistor.

The slope of graphs become large at the ends. The slope gives value of $\frac{\Delta I_B}{\Delta V_B}$. Its reciprocal $\frac{\Delta V_B}{\Delta I_B}$ gives input resistance R_I . As graphs run parallel near the ends, all give same value of R_I .

Calculation for output resistance (R_O) : Plot a graph between collector voltage V_C and collector current I_C for 100 μA base current I_B taking V_C along X-axis and I_C along Y-axis.

Plot graphs for different values of I_B . The graphs come as shown in figure below.

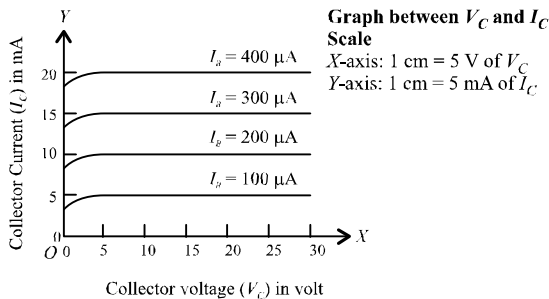

These graphs are called output characteristics of a common emitter transistor.

The slope of graphs becomes almost zero at ends. The slope gives values of $\frac{\Delta I_C}{\Delta V_C}$. Its reciprocal $\frac{\Delta V_C}{\Delta I_C}$ gives output resistance R_O . As graphs run parallel near the ends, all give same value of R_O .

Calculation for current gain (β)

Plot a graph between base current I_B and corresponding collector current I_C for 30 volt collector voltage V_C , taking I_B along the X-axis and I_C along the Y-axis.

The graph comes to be a straight line as shown in figure below.

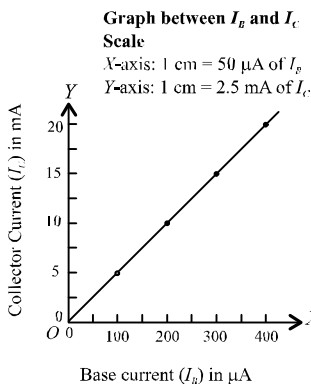

The graph is called current gain characteristic of the common emitter transistor.

The slope of the straight line gives value of $\frac{\Delta I_C}{\Delta I_B}$ which is the value of current gain β of the common emitter transistor.

Calculation of voltage gain (A_V)

Voltage gain = current gain \times resistance gain

$$A_V = \beta \times \frac{R_O}{R_I}$$

21. Identification of diode, LED, Transistor, IC, Resistor, Capacitor from mixed collection of such items

For identification, appearance and working of each item will have to be considered.

1. A diode is a two terminal device. It conducts when forward biased and does not conduct when reverse biased. It does not emit light while conducting.
2. A LED (light emitting diode) is also a two terminal device. It also conducts when forward biased and does not conduct when reverse biased. It emits light while conducting.
3. A transistor is a three terminal device. The terminals represent emitter E , base B and collector C .
4. An IC (integral circuit) is a multiterminal device in form a chip.
5. A resistor is a two terminal device. It conducts when either forward biased or reverse biased. (Infact there is no forward or reverse bias for a resistor). It conducts even when operated with A.C. voltage.
6. A capacitor is also a two terminal device. It does not conduct when either forward biased or reverse biased. Hence it does not conduct with D.C. voltage. However it conducts with A.C. voltage.

22. Using multimeter to

- (i) Identify base of a transistor
- (ii) Distinguish between *npn* and *pnp* type transistor
- (iii) See the unidirectional flow of current in case of a diode and an LED
- (iv) Check the correctness or otherwise of a given electronic component (diode, transistor or IC).

In the following table,

(i) $V_3 > V_2 > V_1$

(ii) $E = \text{emitter}, B = \text{base}, C = \text{collector}$

Table showing arrangement of leads in different types of transistors, their biasing and effect

Row. No.	Type leads	n E	p B	n C	E - B bias junction	B - C bias junction	Effect
1.	Bias	V_1	V_2	V_3	Forward	Reverse	conduction
2.	Bias	V_2	V_1	V_3	Reverse	Reverse	no conduction
	Leads	B	E	C			
3.	Bias	V_1	V_2	V_3	Reverse	Reverse	no conduction
4.	Bias	V_2	V_1	V_3	Forward	Reverse	conduction
	Type	p	n	p			
	Leads	E	B	C			
5.	Bias	V_3	V_2	V_1	Forward	Reverse	conduction
6.	Bias	V_2	V_3	V_1	Reverse	Reverse	no conduction
	Leads	B	E	C			
7.	Bias	V_3	V_2	V_1	Reverse	Reverse	no conduction
8.	Bias	V_2	V_3	V_1	Forward	Forward	conduction

Collector lead is always on the outer side and much separated from others. It can be easily identified.

Hence, base lead is to be identified from between other two close leads.

The multimeter is put in series with the circuit. For this purpose, the common lead *i.e.* –ve or black of the multimeter is taken to be as +ve and terminal marked (P) is taken as –ve. (It is so because the multimeter battery has its positive connected to common and negative connected to P). The knob is kept at D.C. milli-ammeter range for knowing conduction (movement of pointer) and no conduction (on movement of pointer) conditions of the circuit.

Step 1: The collector lead (C) is given highest potential V_3 . The other two leads are given potentials V_1 and V_2 alternately (rows no. 1 and 2).

If there is no conduction in either case, the collector is positive and the transistor is p - n - p type. The collector is forward biased.

If there is conduction in one of the above two cases, the collector is negative and the transistor is n - p - n type. The collector is reverse biased.

In case of conduction (for n - p - n type), the lead having higher potential (V_2) is base, because it makes emitter forward biased. For conditions of row no. 1, central lead is base. For conditions of row no. 4, the outer lead is base.

Step 2: The collector lead (C) is given lowest positive potential V_1 . The other two leads are given potentials V_2 and V_3 alternately (rows no.5 and 6).

If there is no conduction in either case, the collector is negative and the transistor is n - p - n type. The collector is forward biased.

If there is conduction in one of the above two cases, the collector is positive and the transistor is $p-n-p$ type. The collector is reverse biased.

In case of conduction (for $p-n-p$ type) the lead having potential (V_2) is base because it makes emitter forward biased. For conditions of row no. 5, central lead is base. For conditions of row no. 8, the outer lead is base.

- **To see the unidirectional flow of current in case of a diode and an LED.**

Turn the multimeter knob to D.C current of range 50 mA. Connect the multimeter in series with the diode circuit. When the diodes (ordinary diode or LED) are forward biased, multimeter pointer moves to indicate flow of current in the circuits. When bias is reversed, there is no current and multimeter pointer remains at zero.

<https://rebrand.ly/DownloadMore>

The logo consists of the word "End" written in a stylized, cursive font. Above the letter "E", there is a decorative flourish that resembles a stylized "E" or a wave.